



# Call for Proposals:

## CLEAN SKY RESEARCH and TECHNOLOGY DEVELOPMENT PROJECTS (CS-RTD Projects):

# Call Text

Call Identifier  
**SP1-JTI-CS-2013-02**

### Index

Document change log .....	2
Specialised and technical assistance: .....	2
Introduction .....	3
Clean Sky – Eco Design .....	9
Clean Sky – Green Regional Aircraft .....	24
Clean Sky – Green Rotorcraft .....	54
Clean Sky – Sustainable and Green Engines .....	55
Clean Sky – Smart Fixed Wing Aircraft .....	101
Clean Sky – Systems for Green Operations .....	111
Clean Sky – Technology Evaluator .....	164



## Document change log

<i>Date</i>	<i>Topics Impacted</i>	<i>Description</i>

## Specialised and technical assistance:

CORDIS help desk [http://cordis.europa.eu/guidance/helpdesk/home\\_en.html](http://cordis.europa.eu/guidance/helpdesk/home_en.html)

For questions about the proposal submission system Contact:

[DIGIT-EFP7-SEP-SUPPORT@ec.europa.eu](mailto:DIGIT-EFP7-SEP-SUPPORT@ec.europa.eu)

Tel: +32(2) 29 92222

For Questions about Intellectual Property Rights:

IPR help desk <http://www.ipr-helpdesk.org>



## Introduction

Via the Calls for Proposal, Clean Sky aims to incorporate Partners to address very specific tasks which fit into the overall technical Work Programme and time schedule.

Due to the nature of these tasks, the Call is not set up using a set of themes, but it is conceived as a collection of very detailed Topics. The Call text therefore consists of a set of topic fiches, attached here.



Each Topic fiche addresses the following points:

- Topic manager (not to be published)
- Indicative start and Indicative End Dates of the activity
- Description of the task
- Indicative length of the proposal (where applicable)
- Specific skills required from the applicant
- Major deliverables and schedule
- Maximum Topic Budget value
- Remarks (where applicable)

**The maximum allowed Topic budget relates to the total scope of work. A Maximum funding is also indicated. The topic value represents an eligibility criterion for the proposal**

Depending on the nature of the participant, the funding will be between 50% and 75% of the Topic maximum budget indicated. It has to be noted that the Topic budget excludes VAT, as this is not eligible within the frame of Clean Sky.

**The proposal value must be within the threshold of the topic!**

Proposal Submission Forms									
 EUROPEAN COMMISSION <small>7<sup>th</sup> Framework Programme for Research, Technological Development and Demonstration</small>		<b>Collaborative Project</b>					<b>A3.2: Budget</b>		
Proposal Number: nnnnnn			Proposal Acronym: yyyyyyyyyy						
Participant number	Organisation short name	Country	Estimated budget (whole duration of the project)				TOTAL	Total receipts	Requested JU contribution
			RTD	Demonstration	Management	Other			
1	zzzzzzzzzz	CH	564 286	0	35 714	0	600 000	0	450 000
<b>TOTAL</b>			564 286	0	35 714	0	600 000	0	450 000

Make sure this total amount is below the value of the topic!!  
Better, keep at least 5% margin below to be sure.  
Final amount is to be discussed in the negotiation.



## Other Eligibility criteria

All applicants are requested to verify their actual status of "**affiliate**" with respect to the members of the relevant ITD for whose topic(s) they wish to submit a proposal. Applicants who are affiliated to any leader or associate of an ITD will be declared not eligible for the topics of that ITD.

Refer to art.12 of the Statute (*Council Regulation (EC) No 71/2007 of 20 December 2007 setting up the Clean Sky Joint Undertaking*) and to page 8 of the Guidelines.

Pls check on the Clean Sky web site the composition of the ITDs in the dedicated page:

Innovating together, flying greener

Contact Site map Press corner Extranet

About us Environment Activities Calls Publications News & Events

Home > About us > Organisation > Leaders and Associates > ITD Leaders and Associates

Home

### ITD Leaders and Associates

Share Print

**STAY UPDATED**  
SUBSCRIBE HERE

**CALL FOR PROPOSALS**  
Don't miss it. Participate  
8th Call: Closed  
9th Call: Open until 28-07-2011  
[View info on the 9th Call](#)

#### ITD Leaders

Agusta Westland	Airbus	Alenia	Dassault Aviation
EADS Casa	Eurocopter	Fraunhofer	Liebherr
Rolls-Royce	Saab AB	Safran	Thales

#### Associates (per ITD)

Background  
Mission  
Organisation  
Leaders and Associates  
Governing Board  
Clean Sky Team  
Participation & SMEs  
History

## Recommendation to applicants:

In case of deviations from the requirements of the topic (in terms of deadlines, number and type of deliverables, and so on), please state it at the beginning of your proposals as a Caveat, explaining the reasons and justifications for your choice.

You have to clarify your way of compliance with the topic at start of document, in order to properly prepare the evaluation.



## Evaluation

### Thresholds:

As indicated in section 4.6 of the *"Rules for Participation and Rules for Submission of Proposals and the related Evaluation, Selection and Award Procedures"*, each proposal will be evaluated on 6 criteria.

For a Proposal to be considered for funding, it needs to pass the following thresholds:

- **Minimum 3/5** score for each of the 6 criteria,  
**AND**
- **Minimum 20/30 total score**

**Only one Grant Agreement (GA) shall be awarded per Topic.**

### **Calendar of events:**

- **Call Launch: 9 July 2013**
- **Call close: 22 October 2013, 17:00 Brussels time**
- **Evaluations (indicative): 25-29 November 2013**
- **Start of negotiations (indicative): 19 December 2013**
- **Final date for signature of GA by Partner: 20 January 2013**
- **Final date for signature of GA by Clean Sky JU: 31 January 2013**

### **Recommendation to get a PIC**

The applicant is encouraged to apply for a PIC (Participant Identity Code) and to launch the process of validation as early as possible; this will speed up the process of negotiation in the event that your proposal is successful (see <http://ec.europa.eu/research/participants/portal/appmanager/participants/portal>)



## Contacts:

All questions regarding the topics published in this Call can be addressed to:

[info-call-2013-02@cleansky.eu](mailto:info-call-2013-02@cleansky.eu)

Questions received until **20 September 2013** will be considered.

A first version of the Q/A document will be released by **13 September 2013**.

The final version of the Q/A document will be released by **end September 2013**.

Questions having a general value, either on procedural aspects or specific technical clarifications concerning the call topics, when judged worth being disseminated, will be published in a specific section of the web site ([www.cleansky.eu](http://www.cleansky.eu)), together with the answers provided by the topic managers.

All interested applicants are suggested to consult periodically this section, to be updated on explanations being provided on the call content.

Although the compliance is assessed primarily wrt the published call fiche, the proposals taking into account also the remarks in the Q/A may be scored better in terms of relevance and compliance.

## Looking for Partners?

If you are interested in checking available partners for a consortium to prepare a proposal, please be aware that on the Clean Sky web site there is a specific area with links to several databases of national aeronautical directories:

Innovating together, flying greener

Contact Site map Press corner Extranet

About us Environment Activities Calls Publications News & Events

Home » Calls » Seeking partners ? » Looking for partners ?

Home

About us

Environment

Activities

### Looking for partners ?

Share Print

Although a single entity can present proposals, with no need for a consortium to be created, quite often organisations are willing to submit a bid but don't feel as having the expertise in all areas of a particular topic or believe they might be too small to undertake the entire work. In order to help potential applicants in CFPs seeking for partners to prepare jointly proposals, especially SMEs, hereafter a few links to national aeronautics industry directories.

STAY UPDATED  
SUBSCRIBE HERE

CALL FOR PROPOSALS

Don't miss it. Participate  
8th Call: Closed  
9th Call: Open until 28-05-2011

» Know more on the 9th Call



**Reference to TRL:**

When applicable or quoted in the text of topics, the applicants should be aware of the definition of Technology Readiness Levels, as per following chart, being TRL 6 the target for Clean Sky for all applicable technologies:

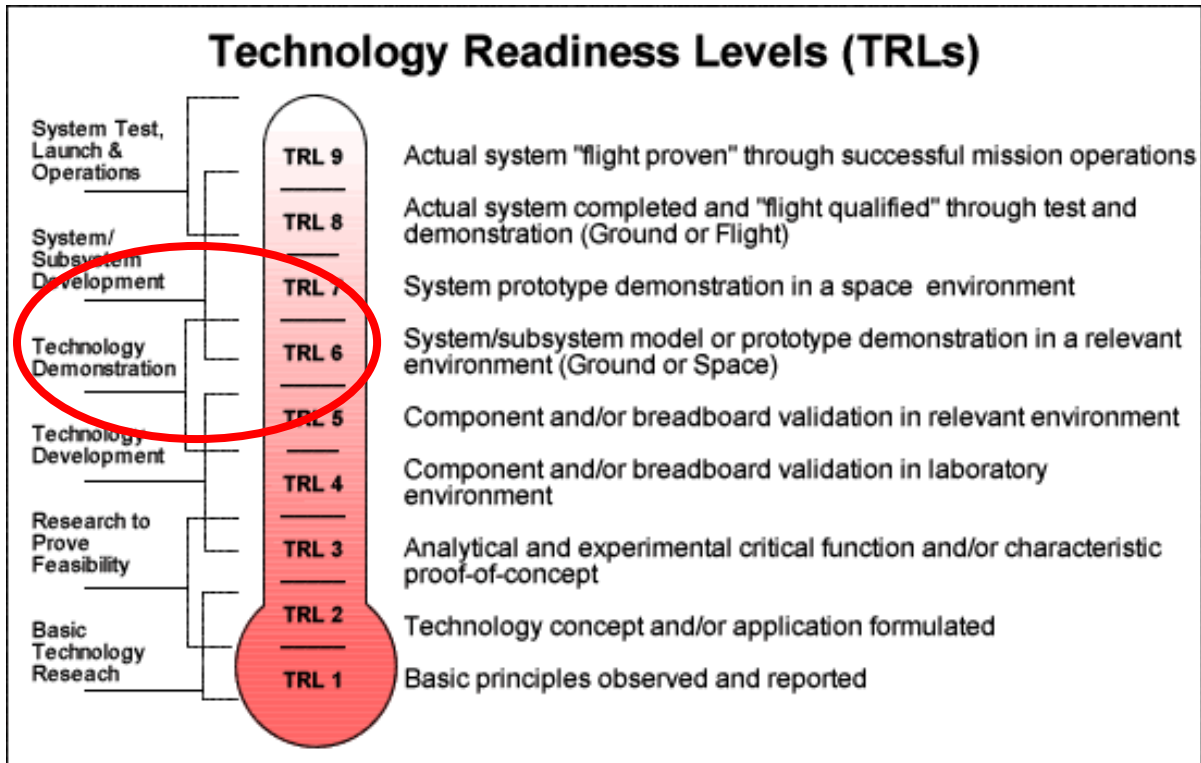



# Clean Sky Joint Undertaking

## Call SP1-JTI-CS-2013-02

European Commission  
Research Directorates



Identification	ITD - AREA - TOPIC	topics	VALUE (€)	MAX FUND (€)
<b>JTI-CS-ECO</b>	<b>Clean Sky - EcoDesign</b>	<b>4</b>	<b>1.200.000</b>	<b>900.000</b>
JTI-CS-ECO-01	Area-01 - EDA (Eco-Design for Airframe)		1.200.000	
JTI-CS-2013-02-ECO-01-072	Manufacturing optimization of a plenum with GFRP cyanate ester-based prepreg		300.000	
JTI-CS-2013-02-ECO-01-073	End of life assessment of Demonstrator B2 "Low weight green metallic fuselage panels" including physical dismantling and recycling		300.000	
JTI-CS-2013-02-ECO-01-074	Application of bio materials based on bamboo fibers to cabin interior composite sandwich panels		250.000	
JTI-CS-2013-02-ECO-01-075	Manufacturing and optimisation of a PEEK scroll by fusible core injection moulding		350.000	
JTI-CS-ECO-02	Area-02 - EDS (Eco-Design for Systems)			
<b>JTI-CS-GRA</b>	<b>Clean Sky - Green Regional Aircraft</b>	<b>7</b>	<b>3.650.000</b>	<b>2.737.500</b>
JTI-CS-GRA-01	Area-01 - Low weight configurations		1.600.000	
JTI-CS-2013-02-GRA-01-052	Development of methods and SW tools for implementation of accurate transfer of loads between numerical models		300.000	
JTI-CS-2013-02-GRA-01-053	Characterization of structure behavior for high frequency phenomena		450.000	
JTI-CS-2013-02-GRA-01-054	Wireless transmission of sensor signals		350.000	
JTI-CS-2013-02-GRA-01-055	Development of novel inspection approaches and automated systems for monitoring CFRP damages on-line		500.000	
JTI-CS-GRA-02	Area-02 - Low noise configurations		1.300.000	
JTI-CS-2013-02-GRA-02-024	Mfg and mechanical demo of a morphing high lift device adv prototype		300.000	
JTI-CS-2013-02-GRA-02-025	Highly-accurate/reliable WT tests community noise assessment of an Advanced TP Regional A/C integrating HLD innovative low-noise design		1.000.000	
JTI-CS-GRA-03	Area-03 - All electric aircraft			
JTI-CS-GRA-04	Area-04 - Mission and trajectory Management			
JTI-CS-GRA-05	Area-05 - New configurations		750.000	
JTI-CS-2013-02-GRA-05-008	Highly-accurate/reliable WT tests community noise assessment of an Advanced GTF Regional A/C integrating HLD innovative low-noise design		750.000	
<b>JTI-CS-GRC</b>	<b>Clean Sky - Green Rotorcraft</b>	<b>0</b>	<b>0</b>	<b>0</b>
JTI-CS-GRC-01	Area-01 - Innovative Rotor Blades			
JTI-CS-GRC-02	Area-02 - Reduced Drag of rotorcraft			
JTI-CS-GRC-03	Area-03 - Integration of innovative electrical systems			
JTI-CS-GRC-04	Area-04 - Installation of diesel engines on light helicopters			
JTI-CS-GRC-05	Area-05 - Environmentally friendly flight paths			
JTI-CS-GRC-06	Area-06 - Eco Design for Rotorcraft			
<b>JTI-CS-SAGE</b>	<b>Clean Sky - Sustainable and Green Engines</b>	<b>12</b>	<b>10.100.000</b>	<b>7.575.000</b>
JTI-CS-SAGE-01	Area-01 - Open Rotor Demo 1		600.000	
JTI-CS-2013-02-SAGE-01-002	Fracture mechanic investigation of a new high temperature Ni-based casting alloy		600.000	
JTI-CS-SAGE-02	Area-02 - Open Rotor Demo 2		3.150.000	
JTI-CS-2013-02-SAGE-02-032	Study and durability of electrically insulative material in aircraft engine chemical environment		500.000	
JTI-CS-2013-02-SAGE-02-034	Health Monitoring -Wireless sensors		1.000.000	
JTI-CS-2013-02-SAGE-02-035	Non-rigid geometry variation simulation for fabricated aero engine structures		450.000	
JTI-CS-2013-02-SAGE-02-036	Non-intrusive Turbine Blade measurements		450.000	
JTI-CS-2013-02-SAGE-02-037	Innovative instrumentation for rotating gauges		200.000	
JTI-CS-2013-02-SAGE-02-038	Effect of tolerance variation in high power density gears		550.000	
JTI-CS-SAGE-03	Area-03 - Large 3-shaft turbofan		3.250.000	
JTI-CS-2013-02-SAGE-03-024	Electric Pump for Safety Critical Aero engine applications		1.750.000	
JTI-CS-2013-02-SAGE-03-026	High bypass ratio fan capability acquisition		1.500.000	
JTI-CS-SAGE-04	Area-04 - Geared Turbofan		700.000	
JTI-CS-2013-02-SAGE-04-025	Scouting high performance steels for gears and bearings		700.000	
JTI-CS-SAGE-05	Area-05 - Turbohaft		0	
JTI-CS-SAGE-06	Area-06 - Lean Burner		2.400.000	
JTI-CS-2013-02-SAGE-06-003	Development of materials, processes, and means to enable the application of piezoelectric materials in aero engine controls.		1.500.000	
JTI-CS-2013-02-SAGE-06-007	Validated Design Methodology for Fuel Manifold Systems		900.000	
<b>JTI-CS-SFWA</b>	<b>Clean Sky - Smart Fixed Wing Aircraft</b>	<b>4</b>	<b>2.900.000</b>	<b>2.175.000</b>
JTI-CS-SFWA-01	Area01 - Smart Wing Technology		0	
<b>JTI-CS-SFWA-02</b>	<b>Area02 - New Configuration</b>		<b>1.200.000</b>	
JTI-CS-2013-02-SFWA-02-042	In-Service Monitoring of LE Contamination		250.000	
JTI-CS-2013-02-SFWA-02-043	Advanced measurement for low speed high scale CROR Wind Tunnel Test		950.000	
<b>JTI-CS-SFWA-03</b>	<b>Area03 - Flight Demonstrators</b>		<b>1.700.000</b>	
JTI-CS-2013-02-SFWA-03-013	Low speed Wind tunnel test for laminar wing demonstrator		1.000.000	
JTI-CS-2013-02-SFWA-03-014	Vibration reduction systems in pylon area		700.000	
<b>JTI-CS-SGO</b>	<b>Clean Sky - Systems for Green Operations</b>	<b>19</b>	<b>11.520.000</b>	<b>8.640.000</b>
JTI-CS-SGO-01	Area-01 - Definition of Aircraft Solutions and exploitation strategies			
JTI-CS-SGO-02	Area-02 - Management of Aircraft Energy		7.940.000	
JTI-CS-2013-02-SGO-02-052	Electrical Starter / Generator disconnect system		700.000	
JTI-CS-2013-02-SGO-02-061	Technology development and fabrication of integrated solid-state power switches		540.000	
JTI-CS-2013-02-SGO-02-064	Cooperative System Design Simulation Environment for Energy System Applications		250.000	
JTI-CS-2013-02-SGO-02-066	HVDC fuses design, development, validation and integration		400.000	
JTI-CS-2013-02-SGO-02-069	High power SiC diodes for Starter-Generator rotating rectifier bridge applications		600.000	
JTI-CS-2013-02-SGO-02-073	Numerical and experimental cross analysis methodology for mechanical impacts on a composite structure		500.000	
JTI-CS-2013-02-SGO-02-074	Thermoelectric cooling solutions in harsh environment design and prototyping		350.000	
JTI-CS-2013-02-SGO-02-075	Power connectors development for Vapour Cycle System and non-pressurized area		300.000	
JTI-CS-2013-02-SGO-02-076	Study, sizing, development, prototyping of high power density, preferably self-air cooled e-motor and corresponding inverter		1.500.000	
JTI-CS-2013-02-SGO-02-077	Power cable modeling for WIPS electromechanical chain.		300.000	
JTI-CS-2013-02-SGO-02-078	Ice Phobic Coating Associated to Low Power Electromechanical Deicers		300.000	
JTI-CS-2013-02-SGO-02-079	Optical Fibre based self-monitoring Motor Drives		800.000	
JTI-CS-2013-02-SGO-02-080	ECS humidity optimisation		300.000	
JTI-CS-2013-02-SGO-02-081	Implementation carbon fibers for rotor of high speed rotating electric machine		500.000	
JTI-CS-2013-02-SGO-02-082	Lithium-ion energy storage module for Integrated 28Vdc Modular Power system		600.000	
JTI-CS-SGO-03	Area-03 - Management of Trajectory and Mission		1.780.000	
JTI-CS-2013-02-SGO-03-024	On-Board Information Correlation for a pilot's complete situational awareness in optimum trajectory decisional process		650.000	
JTI-CS-2013-02-SGO-03-025	Automatic flight plan management tool for integration in bench for avionics equipment validation		500.000	
JTI-CS-2013-02-SGO-03-026	Antenna system design and testing for an avionic weather polarimetric X-band radar		630.000	
<b>JTI-CS-SGO-04</b>	<b>Area-04 - Aircraft Demonstrators</b>		<b>1.800.000</b>	
JTI-CS-2013-02-SGO-04-009	Airline trials of green flight management functions		1.800.000	
<b>JTI-CS-TEV</b>	<b>Clean Sky - Technology Evaluator</b>	<b>0</b>	<b>0</b>	<b>0,000</b>
		topics	VALUE	FUND
		<b>46</b>	<b>29.370.000</b>	<b>22.027.500</b>



**Clean Sky Joint Undertaking**  
**Call SP1-JTI-CS-2013-02**  
**Eco Design**

## Clean Sky – Eco Design

Identification	ITD - AREA - TOPIC	topics	VALUE(€)	MAX FUND (€)
<b>JTI-CS-ECO</b>	<b>Clean Sky - EcoDesign</b>	<b>4</b>	<b>1.200.000</b>	<b>900.000</b>
<i>JTI-CS-ECO-01</i>	<i>Area-01 - EDA (Eco-Design for Airframe)</i>		<b>1.200.000</b>	
JTI-CS-2013-02-ECO-01-072	Manufacturing optimization of a plenum with GFRP cyanate ester-based prepreg		300.000	
JTI-CS-2013-02-ECO-01-073	End of life assessment of Demonstrator B2 "Low weight green metallic fuselage panels" including physical dismantling and recycling		300.000	
JTI-CS-2013-02-ECO-01-074	Application of bio materials based on bamboo fibers to cabin interior composite sandwich panels		250.000	
JTI-CS-2013-02-ECO-01-075	Manufacturing and optimisation of a PEEK scroll by fusible core injection moulding		350.000	
<i>JTI-CS-ECO-02</i>	<i>Area-02 - EDS (Eco-Design for Systems)</i>			

## Topic Description

CfP topic number	Title		
JTI-CS-2013-02-ECO-01-072	Manufacturing optimisation of a plenum with GFRP cyanate ester-based prepreg	<b>End date</b>	T0 + 16
		<b>Start date</b>	T0

### 1. Topic Description

Environmental Control System (ECS) of aircrafts are composed of the Air Cooling unit which contains a part named Plenum (see picture).

Current Plenum Housing is made with glass fibre fabrics reinforced epoxy resin. All the layers of the fabric are oriented in  $\pm 45^\circ$ . The prepreg is hand lay up on a positive mould and cured in an autoclave using vacuum bags. With the current epoxy resin, the plenum has demonstrated poor behaviour at elevated temperature and in humidity, which is the environment seen by the part during service.

During the scoping and development phases of the Clean Sky Eco Design for Aircraft (EDA) Project, the topic manager selected and characterized a new *cyanate ester prepreg* reinforced with glass fibres. This prepreg demonstrates better behaviour in the service conditions (temperature, humidity). However, the first trials with this new prepreg to manufacture real parts (plenum housing) in an autoclave, highlighted some issues in the reliability and reproducibility of the manufacturing process.

Heterogeneities which have been observed are:

- Different mechanical properties (tensile, ILSS) on parts manufactured with the same process parameters (same batch, same material, same curing...).
- Coloration (pink) of some areas on a same part
- Different thickness in some areas on a same part

This prepreg can also be cured with an out-of-autoclave manufacturing process but this has never been tested by the topic manager.

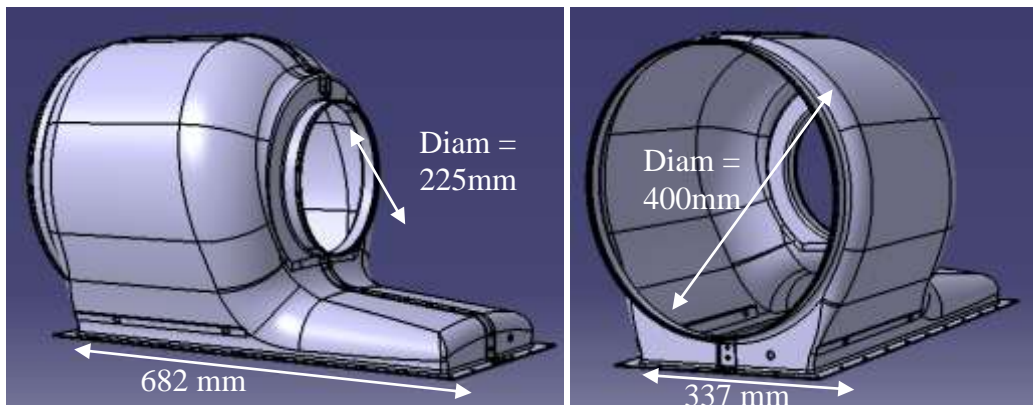

3D of the Plenum housing

The aim of this call is to find partner(s) able to optimize and secure the manufacturing process of the plenum housing. Particularly, the applicant will endeavour to understand why heterogeneities described above appear during the current manufacturing process (in autoclave). The applicant will take advantage of this better understanding on the prepreg behaviour to develop and optimize an out-of-auto`clave process.

*The study that will be proposed should provide guidelines and recommendations to manufacture a plenum with the prepreg already selected by the topic manager (cyanate ester based prepreg reinforced with glass fibres) with both autoclave and out-of-autoclave processes.*

## Clean Sky Joint Undertaking

### Call SP1-JTI-CS-2013-02-ECO-01-072

Guidelines and recommendations will include process windows definition (pressure, vacuum...), atmosphere to be used during curing and post curing, and processing materials (vacuum bags, breathers, release films, peel ply, released agents...) and any other parameters that will be considered relevant by the applicant (e.g. avoid humidity during lay-up, avoid silicon products...).

The project could include the following steps:

- 1) To exchange data with the topic manager according to its experience on the manufacturing of plenum housing with the new cyanate ester prepreg in autoclave. Data include:
  - Nature of the prepreg
  - Processing materials: vacuum bag, release films, peel ply...,
  - Process parameters: pressure, vacuum, curing and post-curing profiles...
  - Problems met on the parts
  - All other data that can be relevant for the applicant.
- 2) To analyse the data collected in step 1). This step shall help in defining input and output data for the next step.
- 3) According to step 1) and 2) and the knowledge of the applicant, definition of a test matrix which will help in identifying the influent factors leading to the heterogeneities (described above) appearing during the current manufacturing process (in autoclave). If relevant, Design of Experiments methodology could be used.

Factors (input data) that could be considered are:

- Properties of the uncured material: Tg, DSC, viscosity, resin content, gel time...,
- Process parameters (e.g. pressure, vacuum, curing and post-curing profiles...),
- Atmosphere during process (e.g. effect of humidity during lay-up and curing, oxidative atmosphere during post curing...),
- Processing materials (e.g. vacuum bag, breathers, release films, peel ply, release agents...).
- Other...

This matrix shall help in better understanding and explaining how this prepreg behaves during the current manufacturing process (in autoclave) and what are the factors which have significant effects on cured composite properties.

The properties (output data) that could be considered are:

- Tg (wet and dry),
- ILSS,
- Tensile strength,
- Porosity,
- Color,
- Thickness,
- Fibres content,
- Resin content,
- Surface finishing,
- Any other properties that will be considered relevant by the applicant.

**Clean Sky Joint Undertaking**  
**Call SP1-JTI-CS-2013-02-ECO-01-072**

- 4) To manufacture samples (in autoclave) according to the test matrix defined in step 3).
  - 5) To perform the test matrix and analyse the results.
  - 6) To identify factors which have strong influence on composite properties (as defined in step 3) with the current manufacturing process (in autoclave).
  - 7) To optimise and secure the manufacturing process in autoclave on samples according step 6).
  - 8) According to the results of steps 5), 6) and 7), to develop and optimize an out-of-autoclave manufacturing process (bagging system and oven) and manufacture samples to control properties defined in step 3.
  - 9) To provide guidelines and recommendations to manufacture a plenum with the cyanate ester prepreg in both autoclave and out-of-autoclave manufacturing processes.
  - 10) To manufacture a plenum housing (as shown in the figure above) with the optimised manufacturing process, either in autoclave or out-of-autoclave (depending on steps 7 and 8 results).
  - 11) The applicant will demonstrate its capacity to transfer the process to an industrial scale. An economic analysis will be done by the applicant.
- The budget of the project shall include cost for the prepreg and fabrication of the positive mould to manufacture the demonstrator.
- TRL5 is expected at the end of the project.

**2. Special skills, certification or equipment expected from the applicant**

- The applicant(s) should have the following facilities and knowledge:
- Strong knowledge and extensive experience on cyanate ester based composites and their processing (prepreg, RTM,...)
  - Strong knowledge, extensive experience on and capabilities for manufacturing thermoset composites
  - Strong experience in composite manufacturing process optimisation
  - Strong knowledge, extensive experience and capabilities to characterize cured and uncured resins properties (Tg, DSC, DMA, viscosity, mechanical testing ...)
- Facilities for implementing the manufacturing process in an industrial scale.

**3. Major deliverables and schedule**

Milestones	Title	Due date
M1	Analysis of the data collected from the topic manager and choice of input and output data for the test matrix	T0+2
M2	Test matrix definition	T0+2
M3	Identification of influent factors on composite properties	T0+9

**Clean Sky Joint Undertaking**  
**Call SP1-JTI-CS-2013-02-ECO-01-072**

Deliverable	Title	Description (if applicable)	Due date
D1	Manufacturing of samples ( <u>in autoclave</u> ) according to the test matrix.	Samples	T0+3
D2	Results and analysis of the test matrix.	Report	T0+9
D3	Optimization and improvement of the manufacturing process <u>in autoclave</u> .	Report	T0+11
D4	Development and optimization of an <u>out-of-autoclave</u> manufacturing process.	Report	T0+14
D5	Properties of samples manufactured <u>out-of-autoclave</u>	Report	T0+15
D4	Guidelines and recommendations to manufacture a plenum with the cyanate ester prepreg <u>in both autoclave and out-of-autoclave</u> manufacturing processes.	Report	T0+16
D5	Manufacturing of a plenum housing with the optimised manufacturing process, <u>either autoclave or out-of-autoclave</u>	Demonstrator	T0+16

**4. Topic value (€)**

The total value of this work shall not exceed:

**300,000 €**

**[Three hundred thousand Euro]**

Please note that VAT is not applicable in the frame of the CleanSky program.

## Topic Description

CfP topic number	Title	Start date	End date
JTI-CS-2013-02-ECO-01-073	End of life assessment of Demonstrator B2"Low weight green metallic fuselage panels" including physical dismantling and recycling	T0	T0+16

### 1. Topic Description

*This project deals with dismantling, recycling and analysis of the end of life (EOL) of the "Low weight green metallic fuselage section" demonstrator.*

A first step of this call focuses on the Life Cycle Assessment (LCA) of several sub-components of the "Low weight green metallic fuselage section" manufactured within Clean Sky Eco-Design Airframe (CS EDA) namely **demonstrator "B2"**. LCA activities will be focused on the end of life phase.

This demonstrator is aiming at validating new technologies developed within CS EDA in the field of *materials, surface treatments and manufacturing processes*.

A second step focuses on the theoretical, then the operational general method for treating large sub assembly (such as paint coated Al, Al-Li, Al-Li-Mg and Mg parts) by defining technical specifications including energy required for dismantling and recycling and by defining an exhaustive list to qualify and quantify the waste materials induced by the recycling.

A third step focuses on optimization of recycling methods in order to increase the reuse potential of the materials, especially of the metals for aircraft application.

The technical work to be carried out by the selected Partner will deal with:

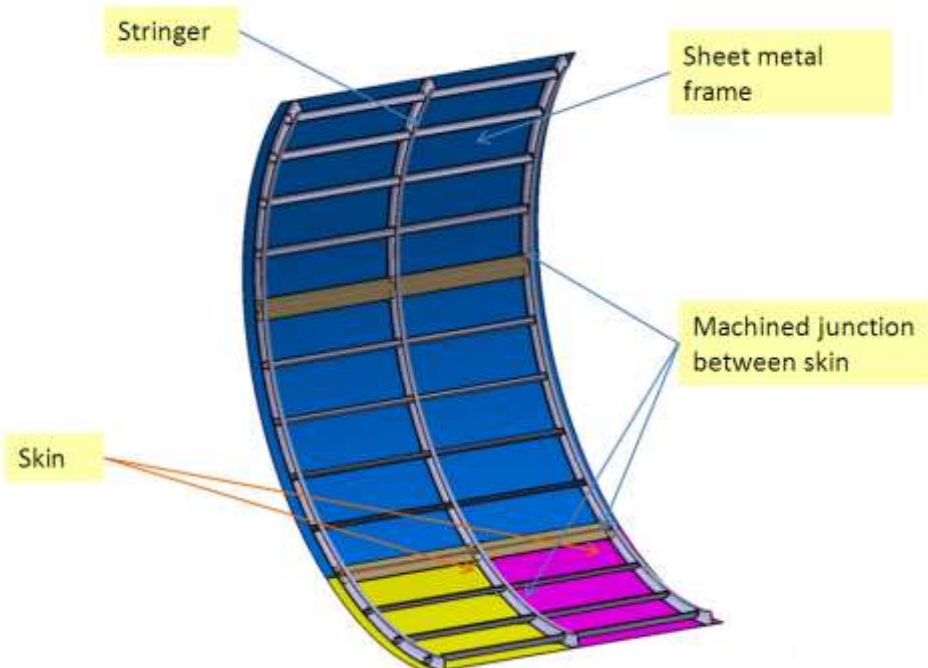

Figure 1: B2 demonstrator panel

## Clean Sky Joint Undertaking

### SP1-JTI-CS-2013-02-ECO-01-073

• **WP1** (T0 to T0+16): Life Cycle Assessment (LCA) of several sub-components of the “Low weight green metallic fuselage section”: demonstrator “B2”.

The study will be limited to the end of life phase (dismantling and recycling) of the reference panel (metallic fuselage section) and of *B2 demonstrator panel(s)* (new technologies fuselage section). The output of the study will be the results of the comparison between both life cycles analysis.

The **reference panel** is as follows:

- Al 2024 for the skin,
  - Al 7175 for a frame,
  - Al 7071 for machined parts
- all coated with conventional surface treatments (chromium)

B2 demonstrator has the same geometry as the reference panel but with the new technologies developed in EDA in the field of materials, surface treatments and manufacturing processes.

The framework of the tasks is described hereunder:

Scope of the study: End of life meaning dismantling (frames, skin, stringers, machined junctions, intercostals and longerons) and recycling.

WP 1.1: Recycling process definition:

Inputs/outputs linked to recycling operations (energy, surface treatment stripping products, wastes and CO<sub>2</sub> emissions) for both reference panel and B2 demonstrator panels.

Deliverable (D8):

The data will be primary data (not analyzed) and will be presented in the collection template provided by the topic manager.

WP 1.2: An evaluation report of the full impact calculated from the previous primary data will be required.

The choice of the LCA tool is left to the appreciation of the selected company.

Recommended method and associated indicators: Impact 2002+ or Recipe.

WP 1.3: Results analysis interpretation

Identification of the operations with a strong environmental impact (most particularly energy consumption).

The B2 demonstrator parts will be compared to reference parts.

Deliverable (D8): Life cycle analysis report.

• **WP2** (T0 to T0+6): Theoretical EOL general method considered for big sub assembly part (such as coated Al, Al-Li, AlMgLi and Mg alloy) will be detailed. Definition of recycling methods to optimize potential reuse of the metals materials will be studied and documented. Energy source for dismantling and recycling will be assessed, waste materials induced by the recycling will be listed and quantified. Choices and technologies involved will be justified.

WP 2.1: Definition of dismantling method and processes

WP 2.2: Definition of recycling method and processes

Deliverables (D2 and D3):

Dismantling specifications

## Clean Sky Joint Undertaking SP1-JTI-CS-2013-02-ECO-01-073

Recycling specifications
<ul style="list-style-type: none"> <li>• <b>WP3</b> (WP3.1 T0+6 to T0+12 →WP3.2 T0+12 to T0+16): Actual dismantling and recycling operations of the sub-component(s) analyzed in WP2 will be described and set into practice.</li> </ul> <p>Main activities:</p> <ul style="list-style-type: none"> <li>- Definition of recycling methods to optimize potential reuse of the metallic materials will be performed.</li> <li>- Energy source for dismantling and recycling operations will be assessed.</li> <li>- Waste materials induced by the recycling operations will be listed and quantified.</li> </ul> <p>The materials sorting, the materials valorization performed by the recycling channels shall be evaluated.</p>
WP 3.1: Dismantling operations WP 3.2: Recycling operations
<p>Deliverables (D5 and D6):</p> <ul style="list-style-type: none"> <li>• A standardized operational process showing the management of the wastes and proving the traceability of the recycled elements is required through a very detailed report.</li> <li>• An in-live demonstration of the dismantling/recycling process is to be performed in front of the topic manager at the selected company's facility or at any other Partner's facility and this demonstration will be consigned in a final report. The possible discrepancies between the specifications and associated operations shall be justified.</li> </ul>

### 2. Special skills, certification or equipment expected from the applicant

<ul style="list-style-type: none"> <li>• LCA at industrial level</li> <li>• Dismantling and recycling capabilities</li> <li>• Certification ISO14001</li> <li>• Strong knowledge in aeronautical Aluminium alloys chemical and mechanical properties.</li> </ul>
--

### 3. Major deliverables and schedule

Deliverable	Title	Description (if applicable)	Due date
D1	WP1–Kick off meeting Minute	Kick off meeting with selected Partner.	T0
D2	WP2.1–Dismantling specifications	Report detailing the dismantling method and processes.	To + 6 Months
D3	WP2.2–Recycling specifications	Report detailing the recycling method and processes.	To + 6 Months
D4	Progress report	Detailing the works already performed and a technical schedule showing the remaining tasks to be performed.	To + 10 Months
D5	WP3.1 – Dismantling phase	Organization and set up of the sorting disposal and dismantling process	To + 12 Months
D6	WP3.2 – Recycling phase	Organization and set up of the elements valorisation and traceability	To + 16 Months
D7	WP3	Progress meeting to be organized with the Partners and selected company to discuss the results. Minutes of in live demonstration.	To + 12 Months
D8	WP1 – LCA	WP1 LCA final report: data collection will be provided within the final report	To + 16 Months
D9	Final report	Contains all the results of the full study.	To + 16 Months



**Clean Sky Joint Undertaking**  
**SP1-JTI-CS-2013-02-ECO-01-073**

**4. Topic value (€)**

The total value of this work package shall not exceed:

**300,000 €**

**[Three hundred thousand Euro]**

Please note that VAT is not applicable in the frame of the CleanSky program.

# Clean Sky Joint Undertaking

## SP1-JTI-CS-2013-02-ECO-01-074

### Topic Description

CfP topic number	Title	End date	TO + 16
JTI-CS-2013-2-ECO-01-074	Application of bio materials based on bamboo fibers to cabin interior composite sandwich panels	Start date	TO

#### 1. Topic Description

*Bamboo* is known to be a durable and efficient material that has been used for centuries in the building industry. The mechanical performance of the tree, and its capability to environmental resistance, suggest good fibre mechanical properties. Moreover, its production is easy, and many species have already been selected for their growing speed and their mechanical performances.

However; there is yet no existing «infinite wire» weaved from the bamboo fibres which can be extracted from the plant. Therefore, the following tasks need to be realised in order to develop and characterize a bamboo-based bio-composite from the current TRL3 to TRL6:

- Determine the correct species that can be suitable for composite application, with respect to the bio-composite requirements (mechanical, growing time, existing fields, repeatability of the harvest, ...)
- Develop a low energy consumption process in order to weave a bamboo wire, and then braid a fabric, which will be further use for composite manufacturing.
- Characterize the mechanical properties of the thread and the fabrics and improve the products.
- Realize composite samples for mechanical and environmental evaluation, and compare them with state of the art technology (glass fibre composite) and other bio-fibres (comparison is based on bibliographic studies and material data from Clean Sky (CS) Eco-Design Airframe (EDA) consortium companies). Impregnation will be realized with state of the art epoxy resins and commercially available bio-resins, or bio-resins developed in another CS EDA project. Sample manufacturing will include sandwich parts with aluminium or nomex core and skins manufactured via bio-fibers prepregs. Some of these parts will be used for one of the cabin interior demonstrator of CS EDA “Mid-cabin cabinet” which is described hereafter. The demonstrator parts will be sandwich panels, possibly moulded in shape, with the integration of fasteners such as moulded-in inserts. Definition and justification of these parts is not in the scope of the project.

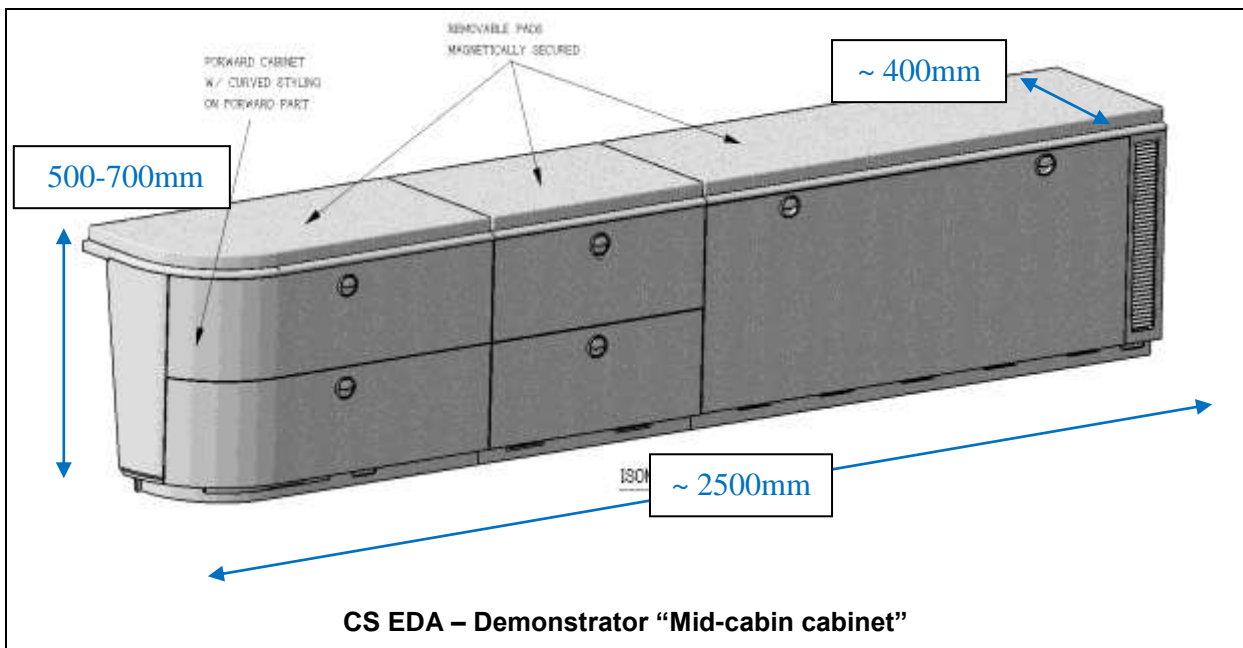

**Clean Sky Joint Undertaking**  
**SP1-JTI-CS-2013-02-ECO-01-074**

**2. Special skills, certification or equipment expected from the applicant**

<p>The following skills and equipment are required:</p> <ul style="list-style-type: none"> <li>- Knowledge of the different bamboo species growing around the world, in order to be able to select the appropriate materials for aeronautic applications (and in respect with existing fields, food plantations, etc.)</li> <li>- Relations with bamboo fiber possible suppliers in countries producing bamboo.</li> <li>- Technical background on other projects involving bamboo is an advantage.</li> <li>- Knowledge of possible processes leading to bamboo fibres extraction from the bamboo plant, with low energy consumption and low chemical products use (especially solvents)</li> <li>- Capability of weaving an infinite bamboo thread from smaller bamboo fibres</li> <li>- Capability of weaving a fabric from the bamboo thread</li> <li>- Capability of impregnating the bamboo fabric with epoxy resin to realize prepreg material up to a prototype production batch of ~ 20 m<sup>2</sup>. Remark: trials adequate to the purpose may be needed.</li> <li>- Capability of mechanical testing</li> <li>- Necessity to have an industrial production possible in the future.</li> </ul>
--

**3. Major deliverables and schedule**

<b>Deliverable</b>	<b>Title</b>	<b>Description (if applicable)</b>	<b>Due date</b>
1	Bamboo fibres species suitable for aeronautical applications	Selection and description of bamboo species suitable for composites production	T0 +2
2	Development of a low energy consumption process in order to weave a bamboo wire	Description of the innovative process, energy assessment	T0 +6
3	Development of bamboo fabric suitable for resin impregnation	Mechanical characterization of the bamboo wire and the fabric, development of a sizing for fibres impregnation	T0 + 8
4	Bamboo based composites	Development and characterization of the bamboo composites	T0 + 12
5	Bamboo demonstrator	Manufacturing of parts to be integrated in the CS EDA demonstrator "Mid-cabin cabinet"	T0 +14
6	Final report	Final results and summary of the projects main results	T0+16

**4. Topic value (€)**

<p>The total value of this work package shall not exceed:</p> <p style="text-align: center;"><b>250,000 €</b>  <b>[Two hundred and fifty thousand Euro]</b></p> <p>Please note that VAT is not applicable in the frame of the CleanSky program.</p>
---

## Topic Description

CfP topic number	Title	Start date	End date
JTI-CS-2013-02-ECO-01-075	Manufacturing and optimisation of a PEEK scroll by fusible core injection moulding	T0	T0 + 16

### 1. Topic Description

Air cycle machines (ACM) used in air cooling systems integrates usually one of several thermodynamic stages (turbine or compressor) composed of a wheel (rotating part), a potential stator stage (injector or diffuser) and a scroll (See Fig. 1).

The **scroll** is a circumferential static part surrounding the wheel and the stator stage and supplying air to (turbine) or collecting air from the stage.

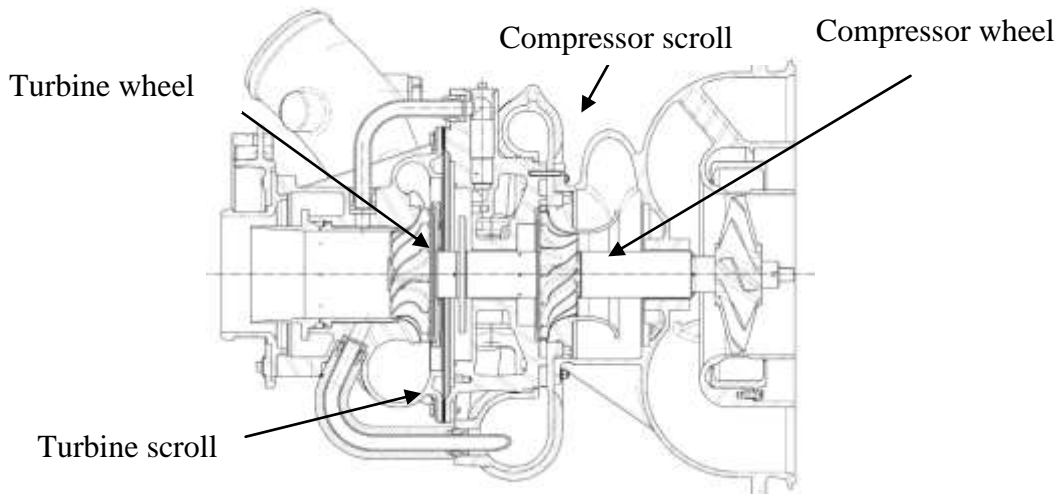

Fig. 1: Cross section of an Air Cycle Machine (ACM).

Scrolls are generally manufactured in aluminium casting which requires surface treatments using and containing the CMR compounds Cr<sup>6+</sup> (CAA, Alodine). In order to reduce weight of the parts but also to prevent the need of hazardous surface treatments, the Topic manager would like to manufacture future *scrolls by injection moulding with PEEK reinforced with short carbon fibres*.

Scroll is a complex shape, hollow part (see views here below). Therefore the partner(s) shall work with the innovative fusible core process.

Three different scrolls are proposed by the topic manager to be adapted according to the new process development. One shall be selected by the partner(s). These parts are presented here below.

As they are currently adapted for the aluminium casting process, their design and interfaces with the other components could be modified and adapted to the thermoplastic injection process. Modifications will be done by the Topic manager during the project, with the support of the applicant.

Clean Sky Joint Undertaking  
 SP1-JTI-CS-2013-02-ECO-01-075

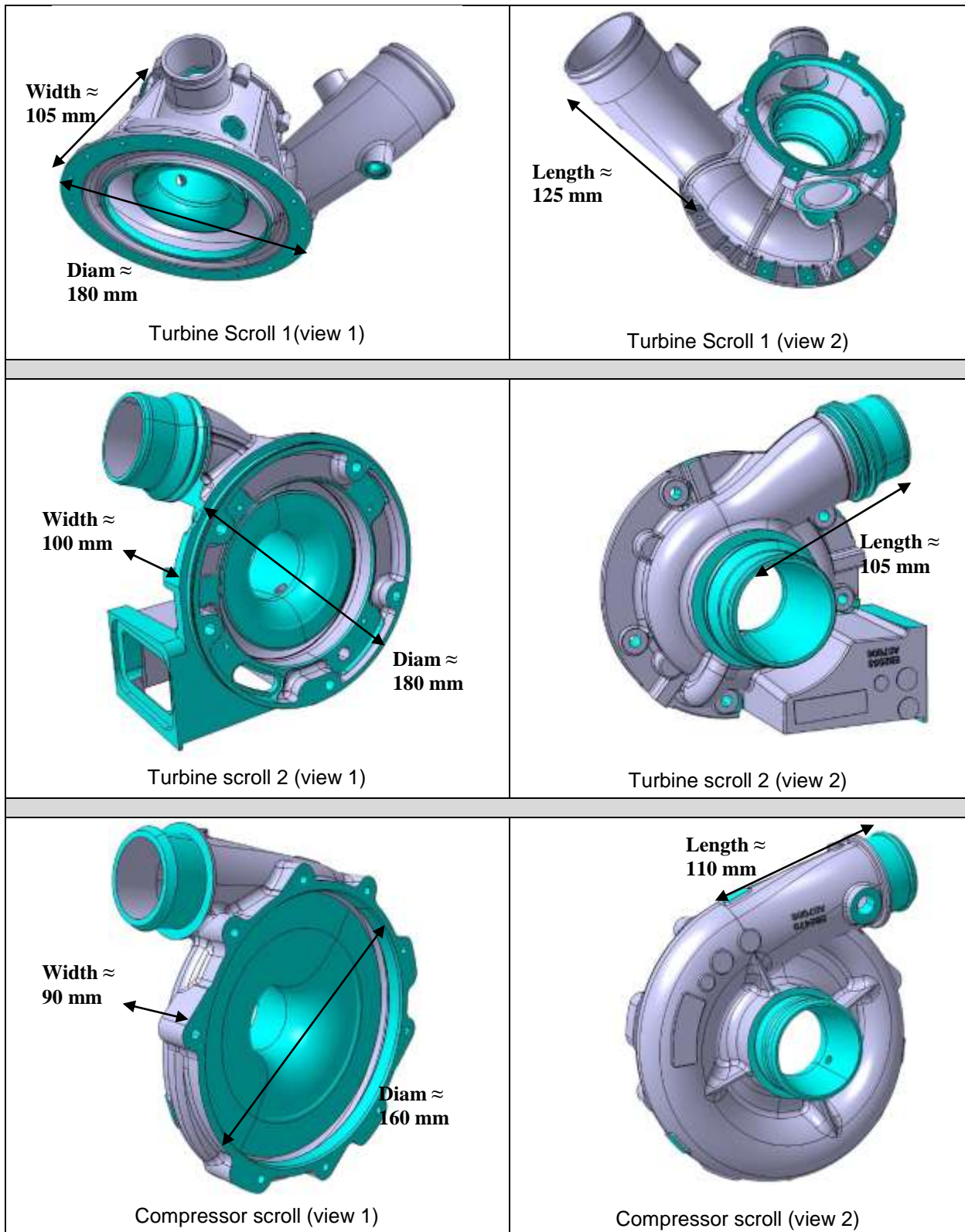

The aim of this call is to find partner(s) able to manufacture by injection moulding and fusible core technology a turbine or compressor scroll with PEEK reinforced with short carbon fibres. Process and materials to be used are already defined by the topic manager:

- **Materials:** PEEK reinforced with short carbon fibres. The precise reference of the PEEK to be used will be provided, by the topic manager to the applicant, at the beginning of the project.

## Clean Sky Joint Undertaking

### SP1-JTI-CS-2013-02-ECO-01-075

- **Process:** injection moulding and fusible core technology.

- 1) The first step of the project will be the choice, in collaboration with the topic manager, of one part among the 3 proposed parts. This choice will be done according to the feasibility of the part with respect to the technology and in collaboration with the topic manager. The technical requirements related to the selected part will be provided by the topic manager to the applicant.
- 2) According to the knowledge of the applicant on the constraints related to the process, modification of the current design will be proposed by the applicant. Final design will be validated by the topic manager according to stress calculations.
- 3) Then the applicant will design an injection mould and the fusible core according to the design of the part. This step shall include rheological simulations.
- 4) The applicant will manufacture the mould and the fusible core accordingly.
- 5) First scroll prototypes will be manufactured and characterized with destructive and non-destructive technologies (e.g. tomography). The number of first scrolls will be defined by the applicant but it should be sufficient:
  - to check the thickness homogeneity (especially thickness of the scroll walls),
  - to control geometry and its compliancy with the defined design,
  - to identify potential defects (porosity, fibres repartition...).
- 6) The design of the mould and of the fusible core, as well as process parameters will be modified and optimized according to the previous step (5). The mould and the fusible core will be then modified. If necessary, the design of the part could also be revised by the topic manager with the support of the applicant
- 7) Steps 5 and 6 will be repeated as much as necessary to obtain a part compliant with the requirements (thickness homogeneity, geometry & no defect). This iterative process will be ended with the final definitions of the mould, fusible core and design of the part.
- 8) When the process will be secured and optimized, the applicant will manufacture 10 scroll demonstrators. The geometry of these 10 demonstrators will be checked by the applicant with non-destructive technologies (as in step 5). One or two of them could be used to control the part with destructive technologies (as in step 5).
- 9) The applicant will demonstrate its capacity to transfer the process to an industrial scale and to ensure aeronautical production rates. An economic analysis will be done by the applicant.

TRL5 is expected at the end of the project.

## 2. Special skills, certification or equipment expected from the applicant

The applicant(s) should have the following facilities and knowledge:

- Extensive experience and strong knowledge on thermoplastic injection moulding (injection process, design and manufacturing of the moulds, calculation, rheological simulation).
- Extensive experience and strong knowledge on fusible core technology.
- Strong knowledge on PEEK reinforced with short carbon fibres and its manufacturing by injection moulding.
- Capabilities for injection moulding, mould design and manufacturing of mould and fusible core.
- Extensive experience on and capabilities for characterisations (thickness homogeneity, geometry, identification of potential defects) by destructive and non-destructive technologies of reinforced thermoplastics
- Facilities for implementing the processes in an industrial scale and ensuring aeronautical production rates.

## 3. Major deliverables and schedule

Milestones	Title	Due date
M1	Choice of the scroll	T0+1
M2	Scroll design modification validated	T0+2

**Clean Sky Joint Undertaking**  
**SP1-JTI-CS-2013-02-ECO-01-075**

<b>Deliverable</b>	<b>Title</b>	<b>Description (if applicable)</b>	<b>Due date</b>
D1	Definition of the mould / fusible core designs	Drawings + Report	T0+3
D2	Manufacturing of the mould and fusible core	Mould / fusible core	T0+9
D3	Manufacturing and control of first scroll prototypes	First scroll prototypes	T0+11
D4	Definition of the final mould / fusible core	Drawings and final mould / fusible core	T0+15
D5	Manufacturing and control of 10 scroll demonstrators	Scroll demonstrators	T0+16
D6	Economic analysis and transfer to industrial scale	Report	T0+16

**4. Topic value (€)**

The total value of this work package shall not exceed:

**350,000 €**

**[Three hundred fifty thousand euro]**

Please note that VAT is not applicable in the frame of the CleanSky program.

**Clean Sky Joint Undertaking**  
**Call SP1-JTI-CS-2013-02**  
**Green Regional Aircraft**

## Clean Sky – Green Regional Aircraft

Identification	ITD - AREA - TOPIC	topics	VALUE(€)	MAX FUND (€)
<b>JTI-CS-GRA</b>	<b>Clean Sky - Green Regional Aircraft</b>	<b>7</b>	<b>3.650.000</b>	<b>2.737.500</b>
<i>JTI-CS-GRA-01</i>	<i>Area-01 - Low weight configurations</i>		<b>1.600.000</b>	
JTI-CS-2013-02-GRA-01-052	Development of methods and SW tools for implementation of accurate transfer of loads between numerical models		300.000	
JTI-CS-2013-02-GRA-01-053	Characterization of structure behavior for high frequency phenomena		450.000	
JTI-CS-2013-02-GRA-01-054	Wireless transmission of sensor signals		350.000	
JTI-CS-2013-02-GRA-01-055	Development of novel inspection approaches and automated systems for monitoring CFRP damages on-line		500.000	
<i>JTI-CS-GRA-02</i>	<i>Area-02 - Low noise configurations</i>		<b>1.300.000</b>	
JTI-CS-2013-02-GRA-02-024	Mfg and mechanical demo of a morphing high lift device adv prototype		300.000	
JTI-CS-2013-02-GRA-02-025	Highly-accurate/reliable WT tests community noise assessment of an Advanced TP Regional A/C integrating HLD innovative low-noise design		1.000.000	
<i>JTI-CS-GRA-03</i>	<i>Area-03 - All electric aircraft</i>			
<i>JTI-CS-GRA-04</i>	<i>Area-04 - Mission and trajectory Management</i>			
<i>JTI-CS-GRA-05</i>	<i>Area-05 - New configurations</i>		<b>750.000</b>	
JTI-CS-2013-02-GRA-05-008	Highly-accurate/reliable WT tests community noise assessment of an Advanced GTF Regional A/C integrating HLD innovative low-noise design		750.000	



## Topic Description

CfP topic number	Title	End date	$T_0 + 18$
JTI-CS-2013-GRA-01-052	Development and validation of methodologies and software tools for the implementation of accurate transfer of loads between numerical models	Start date	$T_0$

### 1. Background

A key issue in enabling reliable numerical simulation and consequently effective optimization and weight reduction in the design of aerospace structures is the ability to transfer loads between different type and different resolution of numerical models with minimal loss of accuracy.

One of the usual cases that this is required is the load transfer of pressure or temperature at the surface of a CFD model to a FEM model in order to perform structural or thermal-structural analysis. Of equal importance is also the load transfer from a global FEM model to a refined FEM model in order to perform detail structural analyses.

One of the complexities during the load transfer process is the distance and variation of orientation between the load source point and receiver point due to dissimilar mesh size but also due to variation in geometry due to discretization of the CAD geometry. Higher resolution of discretization results to smaller geometrical deviation between the two types of model.

Therefore in order to be able to accurately map loads it is necessary to be able to verify that no loss of load magnitude or direction has occurred during the transfer process. The greater the accuracy is in the load transfer process, the greatest the contribution to the weight optimization that can be performed since the degree of uncertainty is reduced.

Further to the above, the verification of the complete process through the prototype testing phase by experimental data, and the loads update based on these data is of significant importance for the design process.

### 2. Abbreviations & Definitions

<b>CFD</b>	Computational Fluid Dynamics
<b>FEA</b>	Finite Element Analysis
<b>CAE</b>	Computer Aided Engineering
<b>GUI</b>	Graphics User interface
<b>TM</b>	Topic Manager
<b>NDA</b>	Non Disclosure Agreement

### 3. Reference documents

- a) *"Conservative load transfer along curved fluid–solid interface with non-matching meshes"* R.K. Jaiman a, X. Jiao b, P.H. Geubelle a, E. Loth
- b) *"Common-refinement-based data transfer between non-matching meshes in multiphysics simulations"* Xiangmin Jiao and Michael T. Heath, Computational Science and Engineering, University of Illinois at Urbana-Champaign, Urbana
- c) *"Discrete Data Transfer Technique for Fluid–Structure Interaction"*, Jamshid A. Samareh", NASA Langley Research Center,
- d) *"The State of Current Practice in Engineering Design Optimisation"*, Peter Bartholomew, NAFEMS

#### 4. Topic Description

*The objective of the present topic is to develop, customize and validate a methodology for transferring loads between numerical models for the analysis of fluids (CFD codes) and structures (FEA codes) as used in the simulation and optimization of aerospace structures during the complete design cycle.*

The methodology and software to be developed will enable the accurate prediction of the structure's response to various types of aerodynamic loads and will be integrated into the optimization process/loop for their design. The development will be based on the FEA code already in use, by respecting standard formats of aerodynamic data generated by commercial CFD codes.

The applicant should provide all the required methodology, software tools, demonstration cases, validation process and documentation in order to enable the transfer of a variety of type of loads like pressure, temperature and force, from one type of computational physics model to another type, having a dissimilar mesh. A similar type of load transfer should also be possible to be performed within the same type of computational physics model, but with dissimilar model resolution as is the case for detailed FEA sizing from a global FEA model.

Furthermore a methodology and software code for design optimization of aerospace structures with emphasis in weight reduction is to be developed. All the above should be integrated in a GUI enabling the handling and visualization of the processed models and loads.

#### 5. Activity Description

The applicant is responsible for providing the following deliverables:

##### **A) Software tools**

**A1)** Development of a software application that will enable the mapping of scalar and vector load values such as pressure, temperature and force from a finely meshed CFD model at UNV universal file format (and one additional type to be defined prior contract initiation), to a coarse structural mesh of MSC/PATRAN neutral file format and also to STEP AP209 format. The load mapping methods to be employed should ensure accurate transfer of the above loads.

**A2)** Development of a software application that will enable mapping of above type of loads from a coarse structural mesh in MSC/PATRAN neutral file format to a fine structural mesh of the same format. The loads from the fine to the coarse mesh should be accurate in both a global and a local level. This should be verified by preserving global resultant loads between the two meshes but also local load distribution. Therefore at least two load transfer methods should be incorporated in the mapping algorithm.

**A3)** Provide the capability to verify the load transfer process of deliverable A2 by means of visual verification through a two parameter plot function (load versus model dimension) for a user preselected cross section on the FEM model, without the user needing to perform manual plotting using a spreadsheet type of software.

**A4)** Provide the capability for a given pressure distribution on a structural mesh to generate nodal force distribution on these elements and the opposite in MSC/PATRAN neutral file format and STEP AP209 format. This nodal force and pressure distribution should have been previously mapped on a test case FEA model described below in numerical validation section.

**A5)** The manipulation and comparison of loads should be made possible with the provision of a windows based GUI. This user interface should be used in order to display the loads on the meshed surfaces both prior mapping and after. It should also provide the capability to view and edit the content of the relevant input and output file types within the same application.

**A6)** Development of an optimization code that can be linked with a pre-existing FEA solver (NASTRAN) or CAD as 3DS CATIA in order to control the geometrical parameters affecting generated mesh. Capabilities of the optimization tool should be demonstrated by performing a design optimization demo case of a wing rib. Relevant geometrical data for that purpose will be provided by the topic manager.

**B) Numerical Validation**

**B1)** Demonstrate of the accurate transfer of loads both from dissimilar mesh size models of different file type and also of the same file type by use of a numerical model exhibiting a double curvature surface as the region of the wing to fuselage junction. The actual geometry to be employed will be decided in agreement with the topic manager. The applicant should perform a CFD analysis in order to evaluate the loads generated on the part.

**B2)** Validation of the complete process of load transfer is to be performed on a scaled model such as a wing (as per section C below) that will be analyzed both aerodynamically and structurally in order to verify correct load evaluation as compared to the measured values of pressure and strain.

**C) Experimental validation of the load transfer process**

**C1)** The applicant should provide a scaled physical model of a wing type of structure which will be tested in a subsonic wind tunnel performing both static pressure and strain measurements under steady flow conditions. Its dimensions will be defined based on combination of minimum reliable/measurable strains that can be measured, maximum available wing tunnel working area and flow velocity. The maximum size is not anticipated to exceed a span of 2 meters.

The wing will be of rectangular shape and small thickness allowing the installation of strain gauges at its interior and of pressure pick-up points at its surface so that sufficient pressure and strain measurements could be performed, in order to verify both aerodynamic pressure distribution and resulting strain field. Installed instrumentation should also allow validation of global model resultants.

**C2)** A methodology to correlate test results with numerical results and also the capability to update applied loading spectrum to the numerical model should be provided in order to enhance the accuracy of the simulation process.

**D) General comments**

Software routines should be written in one of the following programming languages: C, C++, or C#. The source code of the software should be delivered to the topic manager in order to facilitate the capability of further improvements - upgrade of the code in the future. The topic manager reserves the right to modify and improve the code developed without needing to submit royalties to the subcontractor at any time.

For the development and validation phases, any – adequately validated – CFD code could be used. Giving access to this CFD code during development and following submission of the deliverables is desirable and will be considered advantageous during proposal evaluation.

All above software routines should be integrated in a common working environment. The ability to compile the executable in either windows based or Linux based operating systems should be available. For deliverables A1 to A4 the applicant should provide software documentation presenting enough information for a user to understand inner and outer dependencies of the code in order to maintain, do minor alterations and compile it (i.e. modify format of output files). The documentation should include the following:

- i) High Level Functional Block Diagram of the algorithm used as well as references to relevant papers.
- ii) instructions on how to compile it and requirements of the source and target machines.

The topic manager reserves the right to alter the file format needed to be generated by the CFD and FEA load mapping software, prior initiation of contract. In any case the type of files to be used will not exceed a number of two for each one of the above CAE disciplines.

During the proposal evaluation phase the contractor should provide a detailed description and schedule of how he will accomplish the required deliverables

Any third party data that may need to be provided to the applicant by the TM such as CAD or CAE models, material properties and relevant information are confidential and as such will be subject to an NDA.

# Clean Sky Joint Undertaking

## SP1-JTI-CS-2013-02-GRA-01-052

### 6. Interfaces to ITD

The activities of the present topic for proposal are part of the GRA Work Packages 1.6.1 & 1.6.2 tasks with the main objective being the design and weight minimization of parts of the substructure of a wing such as the spars and ribs of the next generation of regional aircraft.

The data exchange of CAE models will be performed via use of standard data formats such as 3DS CATIA, IGES, STEP and NASTRAN. Delivery of data to the TM will be realized through technical reports and software recorded on permanent data storage media.

### 7. Special skills, certification or equipment expected from the applicant

- Proven expertise in code development for numerical simulation and optimization software that is demonstrated by commercial applications and applications in the industry.
- Expertise in performing CFD and FEM analysis of aerospace structural components or similar type of thin shelled structures
- Experience in wind tunnel testing, instrumentation of aerospace structural parts and test data evaluation

### 8. Major deliverables and schedule

For the following schedule of deliverables the topic manager reserves the right to modify the chronological order of the deliveries, based upon needs of his obligations to GRA, and providing the applicant can comply with that re-ordering.

Deliverable	Title	Description	Due date
M0	Effectivity of contract		T0
A1	Preliminary deliverable of CFD to FEA load mapping software	Software application	T0 + 3
A2 B1 B2	Preliminary delivery of FEA to FEA load mapping software Numerical validation Test article preliminary design	Software application CFD & FEA Model CAD model Report	T0 + 5
A3 A6a	Validation software of load transfer process Completion of optimization code	FEA model Software code	T0+7
A4 C1a	Final design of test article Definition of test instrumentation	Manufacturing drawings Instrumentation layout drawings Software code	T0 + 9
A6b	Optimization test case completion	Report FEA model	T0 + 10
C1b	Test article completion, Initiation of instrumentation Initiation of wind tunnel tests	Structure to be tested	T0 + 12
C2	Completion of WT tests and verification of numerical results	Test data report Report	T0+14
A5	Documentation of load mapping transfer software Visual interface integrating SW tools	Documentation Software code	T0 +16
D	Delivery of integrated software package, relevant documentation, and test cases	Software package Documentation-User Manuals Reports Final FEA & CFD Models	T0 +18

### 9. Topic value

The total value of the proposed package shall not exceed

**300.000,00€**

**[Three hundred thousand Euro]**

NOTE: The funding to be from 50 to 75% of this maximum budget value. The total value of the activity is composed of manpower, equipment and all expenses associated with the task.

## Topic Description

CfP topic number	Title	Start date	End date
JTI-CS-2013-GRA-01-053	Characterization of Structural Behaviour for High Frequency Phenomena	T0	T0+24

### 1. Topic Description

#### 1.1. Introduction.

The use of composite materials as principal structural elements in an aircraft requires a complete understanding of mechanical properties. In particular, when structure is subjected to high frequency loading conditions (i.e. low and high energy impacts) phenomena like impact wave propagation, strain rate dependences, delaminations and rupture need to be fully understood in order to certify aeronautical structures, like those proposed within the “Clean Sky - Green Regional Aircraft” initiative. This proposal asks for composite material characterization for impacts in a systematic way: using in parallel numerical and experimental approaches.

#### 1.2. Scope of the work.

The objective of this Topic is to obtain a set of validated numerical models of composite materials adequate to perform impact numerical simulations at aircraft component level. Therefore, two main activities need to be covered within this topic:

1. **Experimental test campaign for material characterization using innovative test techniques.** The main objective is to measure high frequency phenomena in structural tests involving carbon fiber specimens. Proposed techniques and equipment will be agreed with the applicant during negotiation phase. State of the art proposals will be welcome.
2. **Numerical simulations of the tests in order to validate proposed material models.** The simulation tools will be agreed with the applicant during negotiation phase. Non-linear Explicit Finite Element commercial codes used in industry will be very welcome.

The **type of materials** investigated will be carbon fiber composites used in aeronautical structures. The samples and structures analyzed will be typical configurations of:

- Monolithic unidirectional laminates
- Monolithic woven laminates
- Typical sandwich configurations

The loading conditions need to cover from static to dynamic loads scenarios which allow studying typical failure mechanisms like damage, delamination and rupture. The range of energy involved will vary from low levels typical of “tool drop” situations up to ranges of high frequency phenomena like crashworthiness, bird or ice impacts.

Thus, simulations and tests will follow this approach:

1. **Static and Low Energy** dynamic tests (i.e. drop tower or strain rate tensile / shear tests)
2. **High Energy** dynamic tests (i.e. gas cannon or Hopkinson bar tests)
3. **Test of an aeronautical component focus on the airworthiness of large composite components**, to be determined in the negotiation phase. The experimental techniques and numerical models developed in the former project phase will be applied in this full - scale specimen test.

### 1.3. Requirements.

The selected applicant must be able of:

- Manufacturing composite specimens for testing.
- Performing material characterization tests at low and high energy impact conditions.
- Acquiring measurements of failure mechanisms with innovative techniques of high frequency phenomena: damage, delamination and rupture.
- Developing numerical models of composite material using non-linear Explicit Finite Elements approaches.
- Numerical model validation with the experimental information extracted from the test campaign.
- Performing impact tests of full - scale aeronautical components (tooling, test development, instrumentation and analysis) and validation of results with numerical techniques.

### 1.4. Required results.

- Composite material models and simulations validated with the tests performed within the proposal.
- Documentation of the numerical simulations and range of application.
- Documentation of tests techniques and results obtained within the proposal: test description and data measurements.

**Note:** Due to the scope of the project involving different disciplines it is required a strong interaction between the applicant and the Clean Sky core partner. In fact, a consortium of applicants involving specialist in composite materials, simulation, test techniques, tooling and manufacturing will be welcome.

## 2. Special Skills, certification or equipment expected from the applicant

<ul style="list-style-type: none"> <li>• Proved experience in non-linear Finite Element numerical simulation. Development of composite material models covering from elastic range up to failure.</li> <li>• Use of commercial software compatible with industry standards is a "must".</li> <li>• Proved experience in impact tests of composite materials: military and/or aeronautical fields.</li> <li>• Experimental facilities adapted for high velocity impacts: projectile manufacturing, specimen frame attachment and impact installations.</li> <li>• Proved experience at impact tests under aeronautical quality requirements.</li> <li>• High accuracy systems for impact tests monitoring: redundant velocity measurements, high speed video recording system, damage, delamination and rupture evaluation.</li> <li>• Knowledge of composite materials. Manufacturing capacity of tests specimens.</li> <li>• Capacity of testing real – size aeronautical component at controlled impact conditions: from low energy up to high energy situations.</li> </ul>
--

## 3. Major deliverables and schedule

Del. Ref. Nr.	Title	Description (if applicable)	Due date
D1.4 - 01	Static and Low Energy Tests Specification: Test Matrix + Equipment.	Technical Report	<b>T0 + 4</b>
D1.4 - 02	Static and Low Energy Tests coupons manufacturing	Samples delivery	<b>T0 + 6</b>
D1.4 - 03	Static and Low Energy Tests Results.	<b>Technical Report and Test Data</b>	<b>T0 + 8</b>
D1.4 - 04	Static and Low Energy Tests Numerical Simulations.	Technical Report and Numerical Models	<b>T0 + 8</b>
D1.4 – 05	Project Progress: 8 months.	<b>Presentation</b>	<b>T0 + 8</b>
D1.4 – 06	High Energy Tests Specification: Test Matrix + Equipment.	Technical Report	<b>T0 + 12</b>
D1.4 – 07	High Energy Tests coupons manufacturing	Samples delivery	<b>T0 + 14</b>
D1.4 – 08	High Energy Tests Results.	<b>Technical Report and Test Data</b>	<b>T0 + 16</b>
D1.4 – 09	High Energy Tests Numerical Simulations.	Technical Report and Numerical Models	<b>T0 + 16</b>

## Clean Sky Joint Undertaking SP1-JTI-CS-2013-02-GRA-01-053

D1.4 – 10	Project Progress: 16 months.	<b>Presentation</b>	<b>T0 + 16</b>
D1.4 – 11	Aeronautical Structure Impact Test Specification: Test Matrix + + Tooling + Equipment.	Technical Report	<b>T0 + 20</b>
D1.4 – 12	Aeronautical Structure Impact Test specimen manufacturing.	Specimen delivery	<b>T0 + 22</b>
D1.4 – 13	Aeronautical Structure Impact Test Results.	<b>Technical Report and Test Data</b>	<b>T0 + 24</b>
D1.4 – 14	Aeronautical Structure Impact Test Numerical Simulations.	Technical Report and Numerical Models	<b>T0 + 24</b>
D1.4 – 15	Numerical Simulations and Test Activities Analysis.	Technical Report	<b>T0 + 24</b>
D1.4 - 16	Project Conclusions.	<b>Presentation</b>	<b>T0 + 24</b>

#### 4. Topic value

The total value of proposals for this topic shall not exceed:

**450,000 €**  
**[Four hundred fifty thousand euro]**

- Any proposal with a budget larger than the amount shown will be automatically declared ineligible and will not participate in the evaluation.
- The funding to be from 50 % to 75 % of this maximum budget value. The total value of the activity is composed of manpower, equipment and all the expenses associated with the task.
- Please note that VAT is not applicable in the frame of the *CleanSky* program.

#### 5. Remarks

- *The meetings for project monitoring will be held at Topic manager plant. It is foreseen a meeting every four months. The applicant is request to quote the related costs in the proposal.*
- *Experience on the required subject must be referred by the applicant.*

## Topic Description

CfP topic number	Title	Start date	End date
JTI-CS-2013-02-GRA-01-054	Flexible sensor co-operation for structural health diagnosis/prognosis	T0	
			T0+20

### 1. Topic Description

*The subject of this CfP is to explore new means of structural damage detection through the fusion of information from heterogeneous sensor arrays for ad-hoc scenarios, including also flexible arrangements for transmission of data, such as wireless.*

#### 1.1 Introduction

The purpose of this CfP is to determine suitable combinations of sensors to monitor damages or potential damages detected after the entry into service of the structural element, including also flexible arrangements for transmission of data, such as wireless.

Part of the work will be based on the analysis of *ad-hoc* scenarios, i.e., scenarios not anticipated during the design of the structure, such as in-service accidental damages, tracking of repairs or monitoring of findings reported in other airframes. In this context, flexible, non-expensive and easy-to-install solutions for autonomous ad-hoc monitoring (either interim or permanent) will be assessed.

#### 1.2 Reference documents

None

#### 1.3 Scope of work:

The work under this proposal is intended to determine the feasibility of the cooperation of heterogeneous sensors, with special focus on wireless transmission of data. The aim is to determine the type, number and arrangement of sensors needed to characterize a given structural damage (diagnosis) along with the prediction of its future evolution (prognosis), including the technological aspects associated to the hardware platform needed. This process involves studies about compatibility and complementariness of different combination of sensors, along with testing in real environments.

In this context, three topics are expected to be explored sequentially:

- Assessment of individual sensing techniques
- Determination of cooperation scenarios
- Testing of cooperation scenarios

##### 1.3.1 Assessment of individual sensing techniques.

In the first step of the works derived from this CfP, the different sensing techniques to be considered will be analysed (and tested, if necessary) individually in order to determine aspects such as:

- Sensing features (individual POD, applications, endurance, maintenance requirements, limitations, sampling rates, etc.)
- Other technical characteristics (electromagnetic compatibility, size and weight, power consumption, limitations to be applied in flammable areas, battery autonomy, hardware requirements, etc.)
- Data transmission details

##### 1.3.2 Definition of cooperation scenarios

As a second part of the studies integrated in this CfP, the cooperation of the different sensors will be determined. For that purpose, different realistic scenarios in terms of geometrical features (e.g., stiffeners, changes in geometry, etc) will be proposed, and the capability to perform diagnosis and prognosis of different types of damage will be considered, including the following topics as a minimum:

- Sensor arrays (i.e., types, number and spatial distribution of sensors)
- Interaction between wireless and cabled sensors



# Clean Sky Joint Undertaking

## SP1-JTI-CS-2013-02-GRA-01-054

- Hardware platform needed to accommodate heterogeneous sensors, including wireless infrastructure
- Synchronization
- Integration and fusion of data

Both metallic and composite structures will be considered in the scenarios.

Different alternatives will be subjected to trade-off assessment throughout this phase.

### 1.3.3 Testing of cooperation scenarios

As a final step of the CfP, the different scenarios defined previously will be tested in order to prove that the theoretical analyses of the previous step were correct.

For this purpose, a set of specimens representative of the scenarios assessed in the previous step will be either manufactured or reused, and damaged artificially. In the cases in which the prognostic capabilities are to be tested, different types of mechanical loads will be applied.

If needed, *in situ* alternative solutions may be tested depending on the results of the tests.

### 1.4 Design review

The technical information regarding the different milestones of this CfP will be compiled into correspondent documentation whose design maturity will evolve through corresponding revision by ITD. In this context, continuous technical assistance and monitoring of the call evolution will be provided by the applicant.

### 1.5 Outcome

Success of this research should be demonstrated through two criteria:

- Achievement of predefined Probabilities Of Detection (POD) for the scenarios analysed involving sensor cooperation
- Demonstration of reliable transmission of data for those scenarios

## 2. Special skills, certification or equipment expected from the applicant

Experience in design and manufacturing of sensing devices for structural health monitoring, either wireless or cabled.

Experience in the installation and/or integration of sensors.

## 3. Major deliverables and schedule

Deliverable	Title	Description (if applicable)	Due date
D1	Individual assessment of sensing techniques	Document(s)	T0+04
D2	Assessment of scenarios	Document(s)	T0+10
D3	Specimens ready for testing	Hardware + Document(s)	T0+12
D4	Test reports	Document(s)	T0+19
D5	Conclusion & Recommendations	Document	T0+20

## 4. Topic value (K€)

### Budget:

The total value of the proposal for this package shall not exceed:

**350,000 €**

**[Three hundred fifty thousand euro]**

NOTE: The funding to be from 50 to 75% of this maximum budget value. The total value of the activity is composed of manpower, equipment and all expenses associated with the task.

**Clean Sky Joint Undertaking**  
**SP1-JTI-CS-2013-02-GRA-01-054**

**5. Remarks**

*The meetings for project monitoring will be held at Topic manager plan. It is foreseen a follow-up meeting every three months, in average. Applicant is requested to quote related costs in proposal.*

*Experience on the required subject must be referred by the applicant*

## Topic Description

CfP topic number	Title	Start date	End date
JTI-CS-2013-GRA-01-055	Development of novel inspection approaches and automated systems for monitoring CFRP damages on-line	T0	T0+24

### 1. Topic Description

#### 1.1. Introduction.

The structural tests on CFRP elements usually require Non- Destructive Inspection (NDT) during execution. These inspections are now performed manually and, hence, require human presence

The aim of this project is to develop a system to perform NDT during test execution in an automated manner and transmission of the results on-line. The advantages of this approach are:

- The total test time reduction and the saving in hours of human presence; especially where we are speaking of test running 24 hours per day.
- The possibility of a very early detection, because no human presence would be required and, hence, this fact enables a larger number of inspections with a significant cost increase.

The system will be used in a structural test TBD but at subcomponent level (for example. CFRP panels under shear, compression, etc); taking into account that the automated NDT should be done while the test article in the test load frame without any disassembly.

#### 1.2. Scope of the work.

This is a summary of the main activities involved in this project

3. Definition of a suitable NDT technique suitable for this purpose, taking into account all the constraints involved in this project.
4. Definition of principle to enable the NDT performance in automate manner.
5. Design and manufacturing of systems to be developed for this purpose. The structural test itself ( rig and systems are not included in this project).
6. Access to data which characterize the damage (i.e: damage surface) “ on-line” in real time, when a client is outside the test area.
7. Proofs and evaluation of the system, including final setup or modifications.
8. Documentation and final report. Conclusion.

A more detailed document will be issued at a later stage of this project for the precise definition of the requirements.

#### 1.3. Requirements.

The selected applicant should demonstrate general experience in several areas (test, NDT, etc) ; specific skills are shown in chapter 2

- NDT of composite specimens for testing.
- Design of automated systems.
- Acquisition equipment
- Transmission of data through web.

#### 1.4. Required results.

- Documentation which define the whole system in all aspects ( mechanical, electronic, acquisition ,etc) in an agreed format.

## Clean Sky Joint Undertaking SP1-JTI-CS-2013-02-GRA-01-055

- Test Report of all proofs and measures performed while this project is developed.

**Note:** Due to the scope of the project involving different disciplines it is required a strong interaction between the applicant and the Clean Sky core partner. In fact, a consortium of applicants involving specialist in NDT composite materials, test techniques, automated systems, data transmission, etc will be welcome.

### 2. Special Skills, certification or equipment expected from the applicant

- NDT of composite specimens for testing.
- Design of automated systems.
- Acquisition equipment.
- Transmission of data through web.
- Structural testing for a full understanding of all involved constraints and general philosophy of the project.

### 3. Major deliverables and schedule

Del. Ref. Nr.	Title	Description (if applicable)	Due date
D - 01	Definition of a suitable NDT technique suitable	Document	<b>T0 + 3</b>
D- 02	Definition of automated system	Document	<b>T0 + 4</b>
D- 03	Definition of data transmission system	<b>Document</b>	<b>T0 + 4</b>
D- 04	General Design of whole system (CDR)	Document/ / CATIA	<b>T0 + 10</b>
D- 05	Rig and equipment ready for assembly	<b>Hardware/documents</b>	<b>T0 + 15</b>
D- 06	Preliminary proofs	Memo signature	<b>T0 + 17</b>
D- 07	Test acceptance	Memo signature	<b>T0 + 19</b>
D-08	Test analysis	<b>Data Records</b>	<b>T0 + 20</b>
D-09	Final Report	<b>Document</b>	<b>T0+23</b>
D-10	Conclusions	<b>Presentation</b>	<b>T0+24</b>

### 4. 4. Topic value

The total value of biddings for this task shall not exceed:

**500,000 €**

**[five hundred thousand euro]**

- The funding to be from 50 % to 75 % of this maximum budget value. The total value of the activity is composed of manpower, equipment and all the expenses associated with the task.
- Please note that VAT is not applicable in the frame of the *CleanSky* program.

### 5. Remarks

*The meetings for project monitoring will be held at Topic manager plan. It is foreseen a follow-up meeting every three months, in average. Applicant is requested to quote related costs in proposal.*

*Experience on the required subject must be referred by the applicant*

## Clean Sky Joint Undertaking SP1-JTI-CS-2013-02-GRA-02-024

CfP topic number	Title		
JTI-CS-2013-2-GRA-02-024	Manufacturing and Mechanical Demonstration of a Morphing High-Lift Device Advanced Prototype.	<b>Start date</b>	T <sub>0</sub> (*)
		<b>End date</b>	T <sub>0</sub> + 12 months

**Note (\*):** T<sub>0</sub> is the effective date of contract

### 1. Topic Description

#### **Short description**

A preliminary concept of a novel morphing architecture was developed to enable the continuous camber variation of a flap segment in compliance with top-level load control requirements related to a next generation Green Regional Aircraft.

Starting from the preliminary drawings of the architecture and pertaining actuation systems, the call essentially addresses all the activities aimed at:

1. the general lay-out optimization to better comply with:
  - industrial standards, mainly in terms of manufacturing/assembly costs reduction,
  - airworthiness requirements for what regards the in-service safety of the overall system;
2. the preparation of the executive drawings for all the components of the optimized configuration, including also details on the expected manufacturing processes and, whereas applicable, the elaboration of specific CAM files;
3. the manufacturing and the assembly of a physical full-scale prototype;
4. the validation of the manufactured prototype by means of functionality, static and dynamic tests.

#### **a. Introduction**

##### **1. Background**

Regional aircraft typically operate over airports located in the neighbourhood of densely populated areas, with a high frequency of taking-off and landing events and, hence, they strongly contribute to the impact of air transport on environmental noise and pollution. Furthermore, due to the typical short range of regional aircraft, whose cruising flight distance is only about the 50% of the overall mission path, the climbing performance and the empty weight of the aircraft have both a strong influence on the entire mission fuel consumption and, again, on gaseous contaminants and noise emissions over airports surrounding regions. For the above reasons the “Low Noise Configuration” project within the GRA ITD is pursuing a dual purpose:

- to assess technologies aimed at reducing airframe noise which during approach and landing phases (with engine power at minimum, high-lift devices deployed and undercarriage lowered) is a major contributor to the aircraft annoyance perceived by the resident population;
- to address technology innovation toward other paramount functions for next generation, green regional aircraft:
  1. highly-efficient aerodynamics to reduce fuel consumption and pollution at cruise condition;
  2. wing loading control to enhance aerodynamic efficiency in all flight conditions and, hence, to reduce fuel consumption and pollution over the whole mission also allowing for steeper initial climb, noise-abatement flight trajectories;
  3. wing loading alleviation to avoid any possible loads exceeding over structural design conditions and, hence, to optimise the wing structural design for weight savings.

In line with what reported at point 2, preliminary studies were carried out in order to define a novel flap concept characterized by morphing camber capabilities. The basic idea behind such concept was to properly control the flap shape so that load control functionalities may be implemented during cruise and off-design conditions (e.g.: climb and descent).

The architectural layout of the morphing structure was preliminary assessed with reference to the outer flap region of the wing depicted in Figure 1.

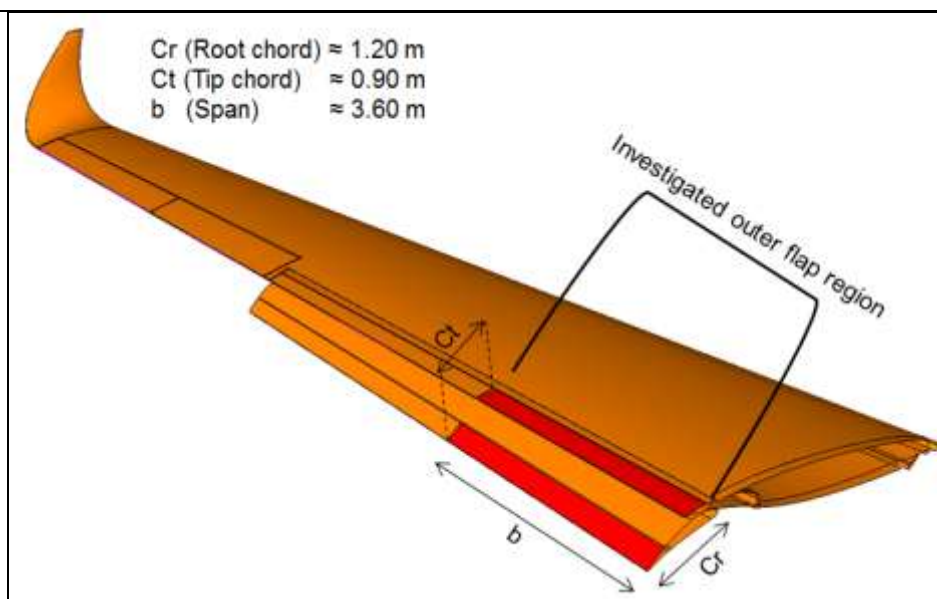

Figure 2 – Outer Flap region (extracted and retracted configurations, LH wing)

Morphing capabilities had to be assured both for flap extracted and flap retracted conditions; the portion of the flap architecture enabling camber morphing was limited to the 30% of the flap chord (such portion has been coloured in red in Figure 1). Preliminary drawings were elaborated for a high TRL structural solution characterized by segmented ribs composed by properly hinged metallic parts in relative rotation; each rib was supposed to be driven by electro-mechanical actuators whose forces and moments were amplified through a suitable actuation chain. Actuators and actuation chains were fully embedded into the flap volume so that no external devices/fairings resulted necessary to morph the camber of flap trailing edge.

## 2. Interface to ITD

The work addressed by the present CfP concerns the manufacturing and testing of a full scale prototype for a morphing flap structure. Preliminary drawings of the structural and actuation concepts as well as FE models developed to get a rough validation of conceived arrangements, will be all provided as reference input. Input data will involve standard file formats of the most largely used tools in aerospace industry.

### b. Scope of the work

A preliminary concept of a novel morphing architecture was developed to enable the continuous camber variation of a flap segment (see Figure 1, par. 1.1.1) in compliance with top-level load control requirements related to a next generation Green Regional Aircraft. Starting from the preliminary drawings of the architecture and pertaining actuation systems, the work will be finalized to:

1. the general lay-out optimization to better comply with:
  - industrial standards, mainly in terms of manufacturing/assembly costs reduction,
  - airworthiness requirements for what regards the in-service safety of the overall system;
2. the preparation of the executive drawings for all the components of the optimized configuration, including also details on the expected manufacturing processes and, whereas applicable, the elaboration of specific CAM files;
3. the manufacturing and the assembly of a physical full-scale prototype;
4. the validation of the manufactured prototype by means of functionality, static and dynamic tests.

### c. Type of work

The work concerns all the necessary activities covering the typical industrialization process of an aeronautical component, from the executive drawings emission up to the manufacturing and test of a physical full-scale prototype providing experimental evidence of component robustness and functionality.

In the light of this consideration, three main types of activities are expected:

- *Pre-manufacturing Design activities* (optimization of component's preliminary layout, preparation of the

## Clean Sky Joint Undertaking SP1-JTI-CS-2013-02-GRA-02-024

executive drawings and elaboration of suitable manufacturing processes).

- *Manufacturing activities*, (realization of component's spare parts, assembly of the component, realization of the assembly and test rigs).
- *Experimental activities* (static, functionality and dynamic tests of the manufactured prototype).

### d. Abbreviations & Definitions

c.o.t.s.	Commercially available Off-The-Shelf
CAD	Computer Aided Design
CAM	Computer Aided Manufacturing
CfP	Call for Proposals
D	Deliverable
e.g.	Example Given
FE(M)	Finite Element (Model)
GVT	Ground Vibration Test
HW/SW	Hardware/Software
LH	Left Hand side
MS	Milestone
Par	Paragraph
PLC	Programmable Logic Controller
TRL	Technology Readiness Level
2D/3D	Two-dimensional/Three-dimensional

### e. Description of Work

According to the objectives recapped in par. 1.2, the concerned activity is characterized by four main tasks. Tasks general description is reported in the next paragraphs.

#### Task 1 – Morphing flap, design review

Preliminary drawings of the morphing flap architecture -and therein embedded actuation system- will be provided as input of this task. They will refer to the outer flap region depicted in Figure 1, par. 1.1.1 (main dimensions: root chord  $\approx$  1.20 m, tip chord  $\approx$  0.90 m, span  $\approx$  3.60 m). Simplified FE models of the conceived system (flap structure + actuation chain) will be also released to give evidence of the analyses performed to justify the goodness of the adopted arrangements.

On the base of this input, the design review of the overall system will be carried out in order to:

1. Optimize the geometrical layout of each single part in order to reduce the manufacturing costs and to simplify the assembling process;
2. Optimize the preliminary layout of the actuation system in order to assure better actuation performances as well as to increase overall system safety in case of actuators failure or jamming.
3. Optimize the layout of the system in order to lower its overall weight.

The design review process may involve changes in preliminarily selected materials, actuators and in all elements connecting the different parts (e.g.: hinges, bushings, screws, rivets).

Whereas applicable, the use of c.o.t.s. components, compliant with aeronautical standards, is considered mandatory. In the light of this statement, no *unconventional* solutions for actuators and structural components should be taken in account during the design review.

All changes applied to the preliminary layout of the system should be supported by rational analyses proving that:

1. Changes do not jeopardize the system's capability to withstand limit (/ultimate) loads without local plasticization (/failure);
2. Changes do not produce negative impacts on the structural stiffness distributions, thus safeguarding

## Clean Sky Joint Undertaking

### SP1-JTI-CS-2013-02-GRA-02-024

- system's capability to reproduce target morphed shapes upon actuation and under external loads;
- system's aeroelastic stability.

#### Input

- Preliminary drawings of the morphing flap architecture both in un-morphed and morphed configurations (Solid Works® step and/or iges files).
- Preliminary drawings of the morphing flap actuation chain both in un-morphed and morphed flap configurations (Solid Works® step and/or iges files).
- Top-level part list of the preliminary flap layout including selected actuators (Excel® file).
- Preliminary FE models of the morphing flap architecture including design load conditions (UGS FEMAP® binary database and related MSC/MD-NASTRAN® bulk data files).

#### Output

- 3D CAD of the system's optimized layout resulting from the design review process (step and/or iges files). [D1]
- Multi-level part list covering all the components of the 3D CAD at the previous point (Excel® file). [D2]
- Actuators data-sheet, if new actuators will be selected during the design review. [D3]
- Technical document describing all changes applied to the preliminary flap layout and providing a thorough explanation of the implemented optimization strategies and outcomes (MS-Word® file). [D4]
- Technical document reporting about all numerical analyses carried out to justify design changes applicability with reference to the applicable airworthiness requirements (MS-Word® file). [D5]
- FE models used for the analyses described at the previous point (MSC/MD-NASTRAN® bulk data files). [D6]

### **Task 2 – Morphing flap, executive drawings and manufacturing process definition**

Starting from the outcomes of the design review process (Task 1), executive 2D and 3D drawings will be elaborated for all the components of the morphing flap. Drawings will be produced according to the typical standards of the aeronautical industry and will therefore contain all top-level indications for the manufacturing (e.g.: main reference quotes, tolerances, surfaces rugosity, special treatments, manufacturing process to be implemented, and so on). Manufacturing process definition will be assessed (time & methods) and CAM files will be prepared whereas required by the type of component to be produced. Whereas specific tools will be designed for components installation and/or sub-components assembly, executive drawings and CAD-CAM files enabling the manufacturing of such tools will be provided as well.

#### Input

Outcomes of Task 1 ([D1],[D2],[D3]).

#### Output

- 2D and 3D executive drawings of all system's components to be manufactured including also any specific assembling tool (DWG, iges, step, file format). [D7]
- CAD-CAM files for the concerned parts. [D8]
- 3D assembly drawing including all systems sub-components to be manufactured or to be purchased (iges and/or step file). [D9]
- Technical document reporting about the manufacturing process (time & methods) for all the concerned parts of the system (MS-Word® file). [D10]
- Installation manual of the morphing flap system (technical document in MS-Word® format describing the step-by-step procedure to assemble all system's components). [D11]

### **Task 3 – Morphing flap, prototype manufacturing**

Outcomes of Task 2 will be used for the implementation of the manufacturing process of the concerned system's spare-parts. C.o.t.s. components (including actuators) will be purchased and the assembling of the prototype will be finally addressed. The assembled prototype will include all the cables necessary to activate and control the actuators. A suitable HW/SW system will be assessed to enable flap morphing through PLC devices. The prototype will reproduce in full-scale the outer flap region addressed by Tasks



## Clean Sky Joint Undertaking

### SP1-JTI-CS-2013-02-GRA-02-024

1 and 2 (main dimensions: root chord  $\approx$  1.20 m, tip chord  $\approx$  0.90 m, span  $\approx$  3.60 m).

#### Input

Outcomes of Task 2 ([D7],[D8],[D9],[D10],[D11]).

#### Output

- a. Assembled flap prototype (Hardware). [D12]
- b. HW/SW system enabling flap morphing control. [D13]

### **Task 4 – Morphing flap, experimental characterization**

Experimental tests will be carried out to:

1. demonstrate the full functionality of the prototype in terms of morphing capabilities under the action of static loads fairly representative of the limit aerodynamic pressures expected in service;
2. demonstrate the capability of the morphing structure to withstand (without plasticization or catastrophic elastic instability) static loads representative of the limit aerodynamic pressures expected in service;

3. characterize the dynamic behaviour of the morphing structure through the identification of the most significant normal modes and related parameters (frequency, damping and generalized mass).

The realization of test rigs, as well as the implementation of suitable excitation/acquisition chains, are implicitly considered as concurring activities for this task.

#### Input

Outcomes of Task 3 ([D12], [D13]).

#### Output

- a. Test plan: technical document describing the type of tests to be performed as well as the experimental approaches to be followed (MS-Word® file). [D14]
- b. Test report: technical document describing all performed tests and obtained results (MS-Word® file). [D15]

#### **f. Requirements**

Sensible data and information will be released at a later date to the successful applicant.

#### **g. Milestones**

**M1** ( $T_0 + 3$  months)

Release of the optimized layout of the morphing flap (3D CAD).

**M2** ( $T_0 + 6$  months)

Release of all the executive documentation supporting the manufacturing of the components and their assembling (2D/3D CAD, CAD-CAM files, installation and manufacturing guidelines).

**M3** ( $T_0 + 10$  months)

Release of morphing flap prototype (fully equipped with actuators and cabling) and HW/SW system for flap control.

**M4** ( $T_0 + 10.5$  months)

Release of the Test plan.

**M5** ( $T_0 + 12$  months)

Release of the Test report.

The monitoring of the work progress will be carried out through:

- Physical (face-to-face) meetings scheduled likely two weeks before the expected achievement of each milestone;
- Teleconferences to be held at the end of each month.

## Clean Sky Joint Undertaking SP1-JTI-CS-2013-02-GRA-02-024

### 2. Special skills, certification or equipment expected from the applicant

The Partner that will undertake aforementioned activities must be equipped with the appropriate hardware, tools and software.

The Partner must moreover possess:

1. consolidated and documented industrial background in design, analysis, engineering, manufacturing of aeronautical components and mechanical systems;
2. strong and documented expertise in the application of CS-25 airworthiness requirements to the design of aircraft components, including system safety assessment with specific reference to aeroelastic concerns;
3. expertise in manufacturing processes definition and implementation according to aeronautical industry standards;
4. expertise in the following CAD software: SolidWorks® (preferred) or CATIA-V5;
5. expertise in the implementation of FE analyses through the following tools:
  - FE solver, MSC/MD-NASTRAN
  - FE pre/post processor, UGS-FEMAP® (preferred) or MSC-PATRAN;
6. documented experience and (preferably ISO-certified) skill in the execution of experimental characterization tests of aircraft components especially for what regards the identification of modal parameters (GVT).

Experience in design, manufacturing and test of morphing structures is highly desirable but does not represent a strict prerequisite.

### 3. Major deliverables and schedule

Deliverable	Title	Description (if applicable)	Due date
D1	Optimized layout of the morphing flap	See Task 1	T <sub>0</sub> + 3 months
D2	Morphing flap part list	See Task 1	T <sub>0</sub> + 3 months
D3	Actuators characteristics and performances	See Task 1	T <sub>0</sub> + 3 months
D4	Design changes description report	See Task 1	T <sub>0</sub> + 3 months
D5	Design changes justification report	See Task 1	T <sub>0</sub> + 3 months
D6	FE models used to verify the proposed design changes	See Task 1	T <sub>0</sub> + 3 months
D7	Spare-parts executive 2D and 3D drawings	See Task 2	T <sub>0</sub> + 5 months
D8	CAD-CAM files	See Task 2	T <sub>0</sub> + 6 months
D9	3D CAD of the assembled flap system	See Task 2	T <sub>0</sub> + 5 months
D10	Manufacturing process report	See Task 2	T <sub>0</sub> + 6 months
D11	Morphing flap installation manual	See Task 2	T <sub>0</sub> + 6 months
D12	Morphing flap prototype	See Task 3	T <sub>0</sub> + 10 months
D13	Equipment for prototype control	See Task 3	T <sub>0</sub> + 8 months
D14	Test plan document	See Task 4	T <sub>0</sub> + 10.5 months
D15	Test report	See Task 4	T <sub>0</sub> + 12 months

### 4. Topic value (K€)

**Budget:** The maximum allowed topic budget shall not exceed:

**300.000,00 €**  
**[Three hundred thousand Euro]**

**Funding:** The maximum funding value ranges from 50% to 75% of the Maximum Allowed Topic Budget indicated above.

Please note that VAT is not applicable in the framework of the CleanSky Programme.

# Clean Sky Joint Undertaking

## SP1-JTI-CS-2013-02-GRA-02-025

topic number	Title	Start date	T <sub>0</sub> (**)
JTI-CS-2013-02-GRA-02-025	Highly-accurate/reliable WT tests for Community Noise assessment of an Advanced Turboprop Regional A/C integrating HLD innovative low-noise design	End date	T <sub>0</sub> + 12 months

Note (\*\*): T<sub>0</sub> is the effective date of contract

### 1. Topic Description

#### Short Description

An advanced Turbo Prop 90-seat regional aircraft configuration should be experimentally investigated through low-speed aeroacoustic WT tests on a complete powered model. Within this test campaign the noise emission in both take-off and landing conditions have to be evaluated.

In this context, main activities being the subject of the concerned topic are as follows:

- Aeroacoustic WT tests on a complete aircraft powered WT model, with scale of  $\approx 1:7$  (A/C full-size, full-span  $\approx 29\text{m}$ ), representative of a Turbo Prop 90-seat regional A/C, equipped with engine-nacelles, propellers, high-lift devices, control surfaces, winglets and landing gears (simplified geometry), at low-speed (Mach  $\approx 0.2$ ) with the aims to:  
Evaluate the noise emitted on ground for the Community noise estimation;  
Evaluate the various noise sources and their influence on the emitted noise.
- Tests will be conducted on the WT model which will be manufactured in the frame of a project under CfP (JTI-CS-2013-01-GRA-02-020).

#### 1.1 Introduction

##### 1.1.1 Background

Within the “Low Noise Configuration” (LNC) domain of the Green Regional Aircraft ITD advanced technologies tailored to future regional airliners are being developed tailored to several A/C configurations with different power plant architectures. The final aim is to contribute to reduce the environmental impact of regional air transport over next decades, according to the strategic road map stated in the “Vision 2020” by ACARE.

In particular, technology innovation toward paramount concepts for a next-generation green Turbo-Prop 90-seat regional A/C is considered, such as:

- highly-efficient wing aerodynamics;
- innovative high lift system design to reduce noise while preserving high lift performance.

##### 1.1.2 Interfaces to ITD

The activity subject of the present Call for Proposals is concerning with the experimental validation in wind tunnel of low-speed acoustic emission of a Turbo Prop 90-seat regional A/C. To this aim a complete powered A/C WT model equipped with engine-nacelles, propeller blades, high-lift devices, control surfaces, winglets and landing gears (simplified architecture), as developed in the frame of the GRA ITD, will be used to be tested in a suitable experimental facility. The model will be designed and manufactured in the frame of a project under CfP (JTI-CS-2013-01-GRA-02-020) and will be made available for this test campaign.

The input/output geometrical model data exchange will be handled through standard formats (IGES, CATIA, NASTRAN). The wind tunnel tests output data will be handled through technical reports and standard format on DVD.

#### 1.2 Scope of Work

Topics and expected outcomes of the activity inherent to the present CfP are dealing with:

Aeroacoustic WT tests on a complete aircraft powered WT model, with scale  $\approx 1:7$  (A/C full-size, full-span  $\approx 29\text{m}$ ), representative of the full-size configuration of a Turbo Prop 90-seat regional A/C, equipped with engine-nacelles, propeller blades, high-lift devices, control surfaces, winglets and nose and main landing gears at low-speed (up to Mach  $\approx 0.2$ ) with the aims to:

- i) evaluate at take-off and landing conditions the whole A/C noise emission in far-field on a polar arc microphone array;
- ii) identify in the same conditions the noise sources by means of a beamforming technique and their contribution to the emitted noise.

- iii) c) verify the effect of a lined flap on the overall noise reduction.

### 1.3 Type of Work

Structural (FEM) modelling of the aircraft WT model, aero-elasticity analyses, wind tunnel testing and experimental data acquisition.

### 1.4 Abbreviations & Definitions

A/C	Aircraft
ACARE	Advisory Council for Aerospace Research in Europe
AoA	Angle of Attack
CAD	Computer Aided Design
CfP	Call for Proposals
EPN	Effective Perceived Noise
EPNL	Effective Perceived Noise Level
FEM	Finite Element Model
GRA	Green Regional Aircraft
HLD	High Lift Device
HW	Hardware
ITD	Integrated Technology Demonstrator
JTI	Joint Technology Initiative
LNC	Low Noise Configuration (one of the technology domains of the GRA ITD)
Mach	Mach number
T/E	Trailing Edge
TP	Turbo Prop
WP	Work Package
WT	Wind Tunnel

### 1.5 Description of Work

According to the objectives described in par. 1.2, the concerned activity will develop through several work packages as described hereinafter.

#### 1.5.1 WP 1 – WT Model dynamical characterization

##### Task 1.1 – FEM model creation and validation

###### Inputs:

- i) Wind Tunnel model requirements
- ii) Technical specification for WT testing
- iii) Aircraft WT model CAD Files



Figure 1 – Pictorial image of future green TP regional aircraft

A FEM model of the complete a/c WT model will be developed from CATIA files, in order to perform a modal analysis that will characterize the dynamical behaviour of model.

The modal behaviour will be useful for the analysis of wind tunnel data. FEM models of basic configuration and optimized one will be evaluated. Models will be validated by correlation with experimental modal analysis.

###### Output:

- i) Aircraft WT model FEM modal analysis – **Deliverable D1.1.1**

##### Task 1.2 - A/C Model WT Interface

###### Inputs:

- i) Wind Tunnel Model Requirements
- ii) Wind Tunnel Facility Drawings

Interface between the A/C model and the Wind Tunnel will be studied in this task.

## Clean Sky Joint Undertaking

### SP1-JTI-CS-2013-02-GRA-02-025

The model has already been tested in a Wind Tunnel Facility for aerodynamic tests. The objective of this task is to verify if any modification should be implemented on the model to suite with the Facility, and if needed to design and actuate such modifications.

This task depends upon the Wind Tunnel Facility that will be selected for this kind of test.

#### Output:

- a) Aircraft model WT Interface report - **Deliverable D1.2.1**

### **Task 1.3 - WT test Instrumentation definition**

#### Input:

- i) Wind Tunnel Model Requirements

The model will be equipped with unsteady pressure transducers (kulites) in order to acquire the pressure fluctuations for the acoustic measurements. Sensors will be placed on model surface flash mounted in order not to interfere with the flow. The positions of sensors will be defined in order to optimize the measurement of noise generated by the Turbulent Boundary Layer, mainly on HLD and landing gear.

An innovative acoustically treated flap design, the so called lined flap, conceived to reduce airframe noise will be also tested. Some Kulite sensors will also be used on the surface of flap, both conventional and lined flap, in order to measure the effect of this solution on the Turbulent Boundary Layer Noise.

A set of microphones out-of-flow will be used to measure the Far-Field Noise on a polar arc (20° - 160°), at a distance where it can be assumed to be in far-field.

Beamforming Technique will be used for the identification of single noise sources (engine, wing, fuselage, Tail, HLD, nose and main landing gear) and their contribution to the global emitted noise.

At least two accelerometers measuring wing tip accelerations will be installed for test security reasons in order to prevent possible occurrence of dynamic aero-elastic instability phenomena. These transducers shall be connected to an emergency test shut down system to cut off divergence development.

#### Output:

- a) Aircraft WT model Instrumentation report - **Deliverable D1.3.1**

### **1.5.2 WP 2 – Wind tunnel Test Activity**

#### **Task 2.1 - Experimental Modal Analysis**

##### Input:

- i) Aircraft WT model (HW)

A preliminary modal analysis test will be performed in order to characterize the model from a dynamical point of view. The results of this activity will be used to validate FEM models.

##### Output:

- a) Experimental Modal Analysis Test Report - **Deliverable D2.1.1**

#### **Task 2.2 – Wind Tunnel Test Campaign**

##### Input:

- i) Aircraft WT model (HW)

Two a/c configurations will be tested.

The first one has classical T/E flap architecture.

In addition to this, a so-called lined flap will have to be tested. This latter is an innovative acoustically treated flap design conceived to reduce airframe noise. Aim of relevant tests is to verify effective noise reduction due to this type of flap structure (with micro-perforation on the external surface) with respect to the conventional one.

The following test matrix will be performed:

1. Aeroacoustic characterization at 5 different speeds of the empty WT;
2. Aeroacoustic characterization at 3 different speeds and 3 AoA of the basic model with Engine OFF;
3. Acoustic characterization at 3 AoA of the basic model engines noise with WT OFF;
4. Aeroacoustic characterization at 3 different speeds and 3 AoA of the lined flap model with Engine OFF;
5. Basic model at 3 speeds and 3 AoA in Take-off and Landing conditions;
6. Lined flap model at 3 speeds and 3 AoA in Take-off and Landing conditions.

Following measurements are envisaged:

- Unsteady pressure measurements;
- Far-Field Noise Measurements on a polar arc;

# Clean Sky Joint Undertaking

## SP1-JTI-CS-2013-02-GRA-02-025

- Beamforming Technique for the identification of noise sources;
- Vibrations on model – WT interface with accelerometers.

Outputs:

- a) WT tests plan – **Deliverable D2.2.1**
- b) WT tests report – **Deliverable D2.2.2**

### Task 2.3 – Data Analysis and extrapolation of EPNdB

Inputs:

- i) WT Test Report
- ii) Wind Tunnel Test Specification

Measured data will be analysed in order to achieve the acoustic behaviour of the model and to extrapolate the results on full scale a/c.

A comparison between conventional flap and lined flap will be performed in order to quantify the effect of the lined flap in terms of noise reduction and, for each configuration, the impact of each noise source on the overall measured noise will be also quantified.

SPL spectra on polar arc will be used to calculate EPNL at 3 Certification points.

Outputs:

- a) Data Analysis – **Deliverable D2.3.1**
- b) Estimation of Certification Noise Levels – **Deliverable D2.3.2**

### 1.6 Requirements

Sensitive information may be released at a later stage to the successful Applicant.

### 1.7 Milestones

**M1** ( $T_0 + 2$  months): WT Model FEM Modal analysis

**M2** ( $T_0 + 6$  months): Model – WT Interface: modifications

**M3** ( $T_0 + 9$  months): WTT Campaign

**M4** ( $T_0 + 12$  months): Data Analysis

Review meetings to monitor on the work progress will be scheduled likely two weeks before the expected achievement of respective milestones above. On such occasions, recovery actions will be decided, in case of delayed activities, trying to stay in the overall initial planning.

## 2. Special skills, certification or equipment expected from the applicant

- Use of computational tools for structural behaviour (FEM) is regarded as a paramount requirement to correctly address the physical phenomena involved.
- Expertise in CATIA V5 software
- Large experience in WT tests on complete A/C model configurations for aero-acoustic purposes. The characteristics of the wind tunnel have to ensure highly-reliable noise measurements and background noise must be negligible if compared to model noise.

## 3. Major deliverables and schedule

Deliverable	Title	Description (if applicable)	Due date
<b>D1.1.1</b>	Aircraft WT model FEM modal analysis	FEM models and Report	$T_0 + 2$ months
<b>D1.2.1</b>	Aircraft model WT Interface report	REPORT	$T_0 + 6$ months
<b>D1.3.1</b>	Aircraft WT model Instrumentation report	REPORT	$T_0 + 4$ months
<b>D2.1.1</b>	Experimental Modal Analysis Test Report	REPORT	$T_0 + 7$ months
<b>D2.2.1</b>	WT tests plan	REPORT	$T_0 + 8$ months
<b>D2.2.2</b>	WT test report	TEST REPORT	$T_0 + 9$ months
<b>D2.3.1</b>	Data Analysis	REPORT	$T_0 + 12$ months
<b>D2.3.2</b>	Estimation of Certification Noise Levels	Report	$T_0 + 12$ months

**Clean Sky Joint Undertaking**  
**SP1-JTI-CS-2013-02-GRA-02-025**

**4. Topic value (K€)**

Budget not to exceeded:

**1,000,000 €**  
**[One million Euro]**

including all cost categories (personnel, computing, travels, materials, WT tests costs, etc.);

**Funding:** ranging from 50% to 75% budget

# Clean Sky Joint Undertaking

## SP1-JTI-CS-2013-02-GRA-05-008

CfP topic number	Title	Start date	T <sub>0</sub> (**)
JTI-CS-2013-02-GRA-05-008	Highly-accurate/reliable WT tests for Community Noise assessment of an Advanced Geared Turbofan Regional A/C integrating HLD innovative low-noise design	End date	T <sub>0</sub> + 12 months

Note (\*\*): T<sub>0</sub> is the effective date of contract

### 1. Topic Description

#### **Short description**

An advanced rear-fuselage engine regional aircraft configuration integrating a Natural Laminar Flow (NLF) wing should be experimentally assessed through low-speed aero-acoustic WT tests on a complete powered model. Within this test campaign the effect of different tail planes configurations (sizing and position), power-plant integration and of wing tip shapes on the A/C aeroacoustic performance should be evaluated.

In this context, main activities being the subject of the concerned topic are as follows:

- Aeroacoustic WT tests at subsonic speed and high Reynolds number, in order to validate the overall aircraft architecture and assess in a representative environment the aircraft acoustic performances in take-off and landing conditions and to evaluate the different noise sources that affect the overall emitted noise.
- Test will be conducted on a complete aircraft powered model, representative of a rear-fuselage Geared Turbo Fan 130-seat regional A/C configuration, equipped with engines, high-lift devices, control movable surfaces, winglets (and other tip extensions), nose and main landing gears (simplified geometry). The WT model will be manufactured in the frame of the project ESICAPIA (under CfP JTI-CS-2012-02-GRA-05-007). The WT test model envisaged scale is  $\approx 1:7$  (A/C full-size, full-span  $\approx 34$ m).

#### **1.1 Introduction**

##### **1.1.1 Background**

Within the “New Configuration” (NC) domain of the Green Regional Aircraft ITD advanced technologies tailored to future regional airliners, developed in other domains of the same ITD and in other ITDs of the Clean Sky JTI, are being integrated by taking into account several A/C configurations and different power plant architectures. The final aim is to contribute to drastically reduce the environmental impact of regional air transport over next decades, according to the strategic road map stated in the “Vision 2020” by ACARE.

In particular, technology innovation toward paramount concepts for a next-generation Green Regional rear-fuselage engine A/C configuration is considered, such as:

- i) Advanced high aspect ratio transonic NLF wing to reduce fuel consumption and pollution at cruising flight condition;
- ii) Innovative high lift system to reduce noise while preserving high lift performance.

##### **1.1.2 Interfaces to ITD**

The activity subject of the present Call for Proposals is concerning with the experimental validation in wind tunnel of low-speed aeroacoustic performances of an advanced future regional A/C, integrating a NLF wing and innovative power plant, as developed in the frame of the GRA ITD. To this aim a complete A/C powered WT model will be tested in a suitable experimental facility. The model will be designed and manufactured in the frame of the project ESICAPIA, under CfP (JTI-CS-2012-02-GRA-05-007) and will be made available for this test campaign.

The input/output geometrical model data exchange will be handled through standard formats (IGES, CATIA, NASTRAN). The wind tunnel tests output data will be handled through technical reports and standard format on DVD.



## **1.2 Scope of work**

Topics and expected outcomes of the activity inherent to the present CfP are dealing with:

i) Aeroacoustic WT tests on a complete aircraft powered model, with scale  $\approx 1:7$  (A/C full-size, full-span  $\approx 34\text{m}$ ), representative of a rear-fuselage Geared Turbo Fan 130-seat regional A/C configuration, equipped with high-lift devices, control movable surfaces, winglets (and other tip extensions), nose and main landing gears, at low-speed (Mach  $\approx 0.2$ ) and high Reynolds numbers with the aims to:

a) Verify the power plant integration, engine location, empennages sizing & position and wing tip concepts optimization from an acoustical point of view, compared to the baseline configuration;

b) Evaluate at take-off and landing conditions the whole A/C noise emission in far-field on a polar arc microphone array;

c) Identify in the same conditions the noise sources by means of a beamforming technique and their contribution to the emitted noise.

## **1.3 Type of work**

Dynamical (FEM) modelling of the aircraft WT model, wind tunnel testing and experimental data acquisition and analysis.

## **1.4 Abbreviations & Definitions**

A/C	Aircraft
ACARE	Advisory Council for Aerospace Research in Europe
AoA	Angle of Attack
CfP	Call for Proposals
EPN	Effective Perceived Noise
EPNL	Effective Perceived Noise Level
FEM	Finite Element Model
GRA	Green Regional Aircraft
GTF	Geared Turbo Fan
HLD	High-Lift Device
HW	Hardware
ITD	Integrated Technology Demonstrator
JTI	Joint Technology Initiative
Mach	Mach number
NLF	Natural Laminar Flow
SPL	Sound Pressure Level
WP	Work Package
WT	Wind Tunnel

## **1.5 Description of Work**

According to the objectives described in par. 1.2, the concerned activity will develop through several work packages as described hereinafter.

### **1.5.1 WP 1 – WT Model dynamical characterization**

#### **Task 1.1 – FEM model creation and validation**

##### Inputs:

- i) CATIA files of a/c basic WT model;
- ii) CATIA files of a/c optimised WT model.



Figure 1 – Sketch of possible aircraft configuration

A FEM model of the complete a/c WT model will be developed from CATIA files, in order to perform a modal analysis that will characterize the dynamical behaviour of model.

The modal behaviour will be useful for the analysis of wind tunnel data. FEM models of basic configuration and optimized one will be evaluated. Models will be validated by correlation with experimental modal analysis.

Output:

- a) Aircraft WT model FEM modal analysis – **Deliverable D1.1.1**

**Task 1.2 - A/C Model WT Interface**

Inputs:

- i) Wind Tunnel Model Requirements
- ii) Wind Tunnel Facility Drawings

Interface between the A/C model and the Wind Tunnel will be studied in this task.

The model will have already been tested in a Wind Tunnel Facility for aerodynamic tests. The objective of this task is to verify if any modification should be implemented on the model to suite with the Facility, and if needed to design and actuate such modifications.

This task depends upon the Wind Tunnel Facility that will be selected for this kind of test.

Outputs:

- a) Aircraft model WT Interface report - **Deliverable D1.2.1**

**Task 1.3 - WT test Instrumentation definition**

Inputs:

- i) Wind Tunnel Model Requirements

The model will be equipped with unsteady pressure transducers (kulites) in order to acquire the pressure fluctuations for the acoustic measurements. Sensors will be placed on model surface flash mounted in order not to interfere with the flow. The positions of sensors will be defined in order to optimize the measurement of noise generated by the Turbulent Boundary Layer, mainly on HLD and landing gear.

A set of microphones out-of-flow will be used to measure the Far-Field Noise on a polar arc (20° - 160°), at a distance where it can be assumed to be in far-field.

Beamforming Technique will be used for the identification of single noise sources (engine, wing, fuselage, Tail, HLD, nose and main landing gear) and their contribution to the global emitted noise.

At least two accelerometers measuring wing tip accelerations will be installed for test security reasons in order to prevent possible occurrence of dynamic aero-elastic instability phenomena. These transducers shall be connected to an emergency test shut down system to cut off divergence development.

Outputs:

- a) Aircraft WT model Instrumentation report - **Deliverable D1.3.1**

**1.5.2 WP 2 – Wind tunnel Test Activity**

**Task 2.1 –Experimental Modal Analysis**

Inputs:

- i) Aircraft WT model (HW)

A preliminary modal analysis test will be performed in order to characterize the model from a dynamical point of view. The results of this activity will be used to validate FEM models.

The Test Matrix will be as follows:

- Baseline configuration
- Optimized Configuration

Output:

- a) Experimental Modal Analysis Test Report - **Deliverable D2.1.1**

**Task 2.2 - Wind Tunnel Test Campaign**

Input:

- i) Aircraft WT model (HW)

The wind tunnel test campaign will be performed at low-speed regime (Mach range  $\approx 0.1 - 0.2$ ) at take-off / landing phases, in order to reproduce in a representative environment at high-lift conditions the noise levels emitted from a GTF rear engine Green Regional Aircraft configuration.

The following test matrix will be performed:

1. Aeroacoustic characterization at 5 different speeds of the empty WT;
2. Aeroacoustic characterization at 3 different speeds and 3 AoA of the basic model with Engine OFF;
3. Acoustic characterization at 3 AoA of the basic model engines noise with WT OFF;
4. Aeroacoustic characterization at 3 different speeds and 3 AoA of the optimized model with Engine OFF;
5. Acoustic characterization at 3 AoA of the optimized model engines noise with WT OFF;
6. Basic model at 3 speeds and 3 AoA in Take-off and Landing conditions;
7. Optimized model at 3 speeds and 3 AoA in Take-off and Landing conditions.

Following measurements are envisaged:

- Unsteady pressure measurements;
- Far-Field Noise Measurements on a polar arc;
- Beamforming Technique for the identification of noise sources;
- Vibrations on model – WT interface with accelerometers.

Outputs:

- a) WT tests plan – **Deliverable D2.2.1**
- b) WT tests report – **Deliverable D2.2.2**

**Task 2.3 – Data Analysis and extrapolation of EPNdB**

Inputs:

- i) WT Test Report
- ii) Wind Tunnel Test Specification

## Clean Sky Joint Undertaking SP1-JTI-CS-2013-02-GRA-05-008

Measured data will be analysed in order to achieve the acoustic behaviour of the model and to extrapolate the results on full scale a/c.

A comparison between basic and optimised models will be performed and, for each configuration, the impact of each noise source on the overall measured noise will be quantified.

SPL spectra on polar arc will be used to calculate EPNL at 3 Certification points.

### Outputs:

- a) Data Analysis – **Deliverable D2.3.1**
- b) Estimation of Certification Noise Levels – **Deliverable D2.3.2**

### 1.6 Requirements

Sensitive information may be released at a later stage to the successful Applicant.

### 1.7 Milestones

**M1** ( $T_0 + 2$  months):

WT Model FEM Modal analysis

**M2** ( $T_0 + 6$  months):

Model – WT Interface: modifications

**M3** ( $T_0 + 9$  months):

WTT Campaign

**M4** ( $T_0 + 12$  months):

Data Analysis

Review meetings to monitor on the work progress will be scheduled likely two weeks before the expected achievement of respective milestones above. On such occasions, recovery actions will be decided, in case of delayed activities, trying to stay in the overall initial planning.

## 2. Special skills, certification or equipment expected from the applicant

- Use of computational tools for structural behaviour (FEM) is regarded as a paramount requirement to correctly address the physical phenomena involved.

- Expertise in CATIA V5 software

- Large experience in WT tests on complete A/C model configurations for aeroacoustic purposes. The characteristics of the wind tunnel have to ensure highly-reliable noise measurements and background noise must be negligible if compared to model noise.

## 3. Major deliverables and schedule

Deliverable	Title	Description (if applicable)	Due date
D1.1.1	Aircraft WT model FEM modal analysis	FEM models and Report	$T_0 + 2$ months
D1.2.1	Aircraft model WT Interface report	REPORT	$T_0 + 6$ months
D1.3.1	Aircraft WT model Instrumentation report	REPORT	$T_0 + 4$ months
D2.1.1	Experimental Modal Analysis Test Report	REPORT	$T_0 + 7$ months
D2.2.1	WT tests plan	REPORT	$T_0 + 8$ months
D2.2.2	WT test report	TEST REPORT	$T_0 + 9$ months

**Clean Sky Joint Undertaking**  
**SP1-JTI-CS-2013-02-GRA-05-008**

<b>D2.3.1</b>	Data Analysis	REPORT	T <sub>0</sub> + 12 months
<b>D2.3.2</b>	Estimation of Certification Noise Levels	Report	T <sub>0</sub> + 12 months

**4. Topic value (K€)**

Maximum Budget not to exceeded:

**750.000,00 €**

**[Seven hundred fifty thousand Euro]**

including all cost categories (personnel, computing, travels, materials, WT tests costs, etc.);

**Funding:** ranging from 50% to 75% of the budget

## **Clean Sky – Green Rotorcraft**

**No topics for GRC**

**Clean Sky Joint Undertaking**  
**Call SP1-JTI-CS-2013-02**  
**Sustainable and Green Engines**

Clean Sky – Sustainable and Green Engines

Identification	ITD - AREA - TOPIC	topics	VALUE (€)	MAX FUND (€)
<b>JTI-CS-SAGE</b>	<b>Clean Sky - Sustainable and Green Engines</b>	<b>12</b>	<b>10.100.000</b>	<b>7.575.000</b>
<i>JTI-CS-SAGE-01</i>	<i>Area-01 - Open Rotor Demo 1</i>		600.000	
JTI-CS-2013-02-SAGE-01-002	Fracture mechanic investigation of a new high temperature Ni-based casting alloy		600.000	
<i>JTI-CS-SAGE-02</i>	<i>Area-02 - Open Rotor Demo 2</i>		3.150.000	
JTI-CS-2013-01-SAGE-02-032	Study and durability of electrically insulative material in aircraft engine chemical environment		500.000	
JTI-CS-2013-02-SAGE-02-034	Health Monitoring -Wireless sensors		1.000.000	
JTI-CS-2013-02-SAGE-02-035	Non-rigid geometry variation simulation for fabricated aero engine structures		450.000	
JTI-CS-2013-02-SAGE-02-036	Non-intrusive Turbine Blade measurements		450.000	
JTI-CS-2013-02-SAGE-02-037	Innovative instrumentation for rotating gauges		200.000	
JTI-CS-2013-02-SAGE-02-038	Effect of tolerance variation in high power density gears		550.000	
<i>JTI-CS-SAGE-03</i>	<i>Area-03 - Large 3-shaft turbofan</i>		3.250.000	
JTI-CS-2013-02-SAGE-03-024	Electric Pump for Safety Critical Aero engine applications		1.750.000	
JTI-CS-2013-02-SAGE-03-026	High bypass ratio fan capability acquisition		1.500.000	
<i>JTI-CS-SAGE-04</i>	<i>Area-04 - Geared Turbofan</i>		700.000	
JTI-CS-2013-02-SAGE-04-025	Scouting high performance steels for gears and bearings		700.000	
<i>JTI-CS-SAGE-05</i>	<i>Area-05 - Turbohaft</i>		0	
<i>JTI-CS-SAGE-06</i>	<i>Area-06 - Lean Burner</i>		2.400.000	
JTI-CS-2013-02-SAGE-06-003	Development of materials, processes, and means to enable the application of piezoelectric materials in aero engine controls.		1.500.000	
JTI-CS-2013-02-SAGE-06-007	Validated Design Methodology for Fuel Manifold Systems		900.000	

## Topic Description

CfP topic number	Title	Start date	End date
JTI-CS-2013-02-SAGE-01-002	Fracture mechanic investigation of a new high temperature Ni-based casting alloy.	T0	T0 + 24 months

### 1. Topic Description

The SAGE project aims at demonstration of engines and technologies to reduce fuel consumption, weight and increased efficiency of engine components. Within the objectives of open rotor development in SAGE1, activities are underway to develop technologies for rotating structures. The rotating structure transmits the torque generated by the engine to the propellers and is subjected to the high temperature exhaust gas from the core engine.

It is likely that the rotating frames will be made as a weld assembly consisting of some cast parts in a newly developed nickel based precipitation hardening superalloy.

The casting composition of this alloy is frozen but the mechanical properties needs to be generated and corresponding fracture mechanisms understood for a range of microstructures (grain sizes) in order to reach a higher technology readiness level (TRL) for this novel alloy.

This CfP topic intends to generate part of the necessary material property database and also contribute to the deeper understanding of important failure mechanisms and hold time effects by detailed fractographic and microstructural investigations.

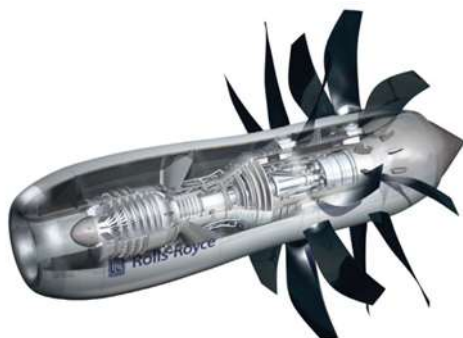

#### **Task 1: Management**

Organisation:

- The partner shall nominate a team dedicated to the project and should inform CfP Topic manager about the name/names of this key staff. At minimum the responsibility of the following functions shall be clearly addressed: Programme (single point contact with Topic Manager), Engineering & Quality.

Time Schedule & Work package Description:

- The partner shall work to the agreed time-schedule (outlined in Part 3) and work package description.
- The time-schedule and the work package description laid out in this call shall be further detailed as required and agreed during negotiation based on the Partner's proposal.

Progress Reporting & Reviews:

- Monthly one-pager and quarterly progress reports in writing shall be provided by the partner, referring to all agreed work packages, technical achievement, time schedule, potential risks and proposal for risk mitigation.
- Regular coordination meetings shall be installed (preferred as teleconference).
- The partner shall support reporting and agreed review meetings with reasonable visibility on its activities and an adequate level of information.
- The review meetings shall be held quarterly either by WEBEX or at Topic Manager's premises or at the partner's premises.



## Clean Sky Joint Undertaking SP1-JTI-CS-2013-02-SAGE-01-002

### **Task 2: Casting of material for the test campaign.**

The first part of the project will be to procure raw material with a chemical composition defined by the topic manager and to perform casting of suitable test plates that can be used for evaluating basic mechanical properties and also preferably the damage tolerance of this alloy.

Cast test plates shall be Hot Isostatically Pressed (HIPed), solution and age heat treated per requirements supplied by the Topic Manager.

After HIPing and heat treatment test plates shall pass X-ray inspection per requirements supplied by Topic Manager.

The bulk of the material in the test plates should have a “nominal grain structure” but material with both a “finer than nominal” and “coarser than nominal grain structure” should also be cast. Test plate configurations and desired microstructures should be agreed with Topic Manager.

The total amount of test specimens is defined in the task below.

### **Task 3: Mechanical Testing**

Based on Task 2, mechanical testing will be carried out to evaluate the behaviour of this alloy at different loading and temperature regimes.

The following types of tests will be performed (the final detailed test programme will be agreed by the topic manager and the CfP consortium in the negotiation phase):

#### **A: Material with nominal material structure**

Test Type	Number of specimens	Number of T's
		T[RT-850°C]
LCF	256	8
LCF (dwell 120 s)	10	5 (a)
FCG (Kb-specimen*)	48	8
FCG (dwell 120s) (b)	10	5 (a)
Threshold value, crack growth, $\Delta K_{th}$ (b)	24	8
(b) $K_{Ic}$	16	8
HCF	120	8
Creep strain (primary, secondary, tertiary)	38	5 (a)
Tensile	138	9
(a)	T[650 - 850°C]	
(b)	Beneficial if this type of test can be done, but not mandatory. If not possible, this testing can be substituted with other of	
(*)	All other listed test types are mandatory small surface flaw	

## Clean Sky Joint Undertaking SP1-JTI-CS-2013-02-SAGE-01-002

### **B: Material with Variation from nominal structure**

Test Type	Number of specimens	Number of T's T[RT-850°C]	Comments
LCF	24	2	Coarse GS**, R=0
FCG (Kb)	4	2	Fine GS, R=0
Creep(primary, secondary, tertiary)	8	2	Fine GS
Tensile	10	2	Coarse GS

(\*\*)Grain Structure

#### **Task 4: Characterization**

The task is here to characterize the material from the mechanical testing and to determine the reason for failure, i.e. determination and characterisation of damage mechanisms/failure modes by advanced microstructural characterisation methods and scanning electron microscopy (SEM) fractography. Detailed material (macro and micro structure) characterization as a support for understanding of important failure mechanisms and hold time and temperature effects for material properties shall also be performed.

### **2. Special skills, certification or equipment expected from the applicant**

The CfP partner/consortium should have significant experience from mechanical testing and casting of superalloys.

Experience in performing applied collaborative industrial research in international environment is considered as essential.

The CfP partner/consortium should have equipment, or an available supply network, for manufacturing of test material using vacuum investment casting. Included in such equipment should also be equipment for Hot Isostatic Pressing (HIP) and furnaces for heat treatment in vacuum (or other suitable protective atmosphere).

The CfP partner needs testing and analysis equipment for evaluating cast test material, or an available supply network. This includes e.g. dimensional control, fluorescent penetrant inspection X-ray, metallography and mechanical testing according to aerospace standards.

The CfP partner/consortium should have experience in castability trials and the typical toolings used to create the specific casting samples for castability trials.

It is considered beneficial if the CfP partner has extensive experience in numerical simulation of the casting process.

The CfP partner/consortium should have equipment or an available supply network for strain controlled low cycle fatigue (LCF), high cycle fatigue (HCF), creep, tensile testing and preferably fatigue crack growth (FCG), at temperatures between room temperature and up to 850C.

Mechanical testing laboratories should be ISO17025 ILAC approved for test specimen machining and the test methods described in Task 3. Test results shall be reported as ISO17025 accredited.

The CfP partner/consortium needs testing and analysis equipment for evaluating the material after the test campaigns, or an available supply network that can perform these evaluations. This includes e.g. equipments such as TEM-EDX, SEM-EDX and LOM.

### **3. Major deliverables and schedule**

D1	Detailed Project Plan.	Task 1: Schedule with milestones.	T0 + 1
M1	Procurement of raw material initiated	Task 2: Procure material.	T0 + 2
M2	Casting performed	Task 2: Cast test plates for mechanical testing.	T0+6
D2	Tensile and fracture toughness report	Tensile and fracture toughness tests characterized and reported	T0+14
M3	Mechanical testing performed	Task 3: Mechanical testing.	T0+18
D3	Documentation of results from the	Task 4: Characterization report.	T0 + 22

**Clean Sky Joint Undertaking**  
**SP1-JTI-CS-2013-02-SAGE-01-002**

	characterization.		
D4	Documentation of results from the mechanical testing.	Task 3: Mechanical testing report.	T0+22
D5	Final report summarizing all results and findings within this WP.	Task 1. A brief final report is requested that highlights the project findings and references all issued reports.	T0 + 24

**4. Topic value (€)**

The total value of this work package shall not exceed:

**€ 600,000**

**[Six hundred thousand Euro]**

Please note that VAT is not applicable in the frame of the CleanSky program.

**5. Remarks**

*Raw material procurement is expected to be included.*

*All documents need to be written in English.*

**Topic Description**

CfP topic number	Title	Start date	End date
JTI-CS-2013-02-SAGE-02-032	Durability study of electrical insulating material in aircraft engine chemical environment	T0	
			T0 + 24 months

**1. Topic Description**

The SAGE2 Demonstration Project aims at designing, manufacturing & testing a Counter-Rotating Open-Rotor Demonstrator. It involves most of the best European Engine & Engine Modules & Sub-systems Manufacturers.

The SAGE2 Demonstrator incorporates two counter-rotating propellers, which should be de-iced. An electrical de-icing system is studied to supply and transfer the power necessary to the de-icing. This implies the design of an electrical winding machine that shall withstand the harsh engine environment that includes:

- High temperature
- Hydrocarbide fluids (i.e. lubricant, fuel, other)
- Hydraulic systems fluids (i.e. ester phosphates)

This demanding environment remains quite a challenge for standard electrical machineries, especially in terms of polymeric insulating material ageing under electrical stresses. Consequently, this project aims to demonstrate the study the durability of already selected thermosets in terms of electrical and insulating properties.

The partner(s) shall evidence experience for material ageing and material electrical characterisation. Other resources and/or competences that could provide pertinent information to get a good understanding of material ageing phenomena will be encouraged.

The partner(s) shall perform the present durability study, in coordination with the de-icing system design study and according to the following development phases:

**Task 1: Project management:**

Planning and steering activities for the project.  
 Quality management of the project.

**Task 2: State-of-the-art of organic polymers and interfaces durability tests**

State-of-the-art report on the organic polymers and interfaces electrical behaviour studying methods during hydrocarbide fluids ageing.

**Task 3: Polymer and interface hydrocarbide ageing test planning**

Materials and interfaces ageing behaviour evaluation methods with test parameters  
 Ageing test plan

**Task 4: Material sample and interface test vehicles processing and characterisation**

Bulk material samples and interface tests samples manufacturing  
 Material initial state characterisation  
 Material interface initial state characterisation

**Task 5: Ageing study and Interpretation**

Material ageing behaviour characterisation  
 Material interface ageing behaviour characterisation  
 Material and interface failure mode during hydrocarbide ageing report

**Task 6: Recommendations**

Design recommendation report  
 Material chemistry optimisation proposal to meet with the requirement or enhance the ageing resistance.

**Clean Sky Joint Undertaking**  
**SP1-JTI-CS-2013-02-SAGE-02-032**

**2. Special skills, certification or equipment expected from the applicant**

NB: a consortium of laboratories and/or companies may answer the call

Extensive experience in high temperature (above 200°C Tg or Tm) material testing and characterisation

Extensive experience in polymer and there interfaces ageing in hydrocarbide and harsh industrial fluids ageing

Extensive experience in polymer failure mode analysis

Extensive experience in polymer electrical characterisation

Experience in polymer interface testing

Experience in high performance polymer chemistry, synthesis and formulation

The applicant should have at disposal equipment and test means for high temperature polymer characterisation and testing

English language is mandatory.

**3. Major deliverables and schedule**

Deliverable	Title	Description applicable) (if	Due date
<b>D1</b>	Monthly progress reports		Every month
<b>D2</b>	Durability technics and methodology state-of-the-art		T0+3
<b>D3</b>	Materials and interfaces ageing test plan		T0+3
<b>D4</b>	Material sample initial state characterisation report and material sample for ageing study		T0+6
<b>D5-1</b>	First test results analysis		T0+12
<b>D5-2</b>	Final test results analysis		T0+22
<b>D6</b>	Recommendations and design guidance report		T0+24

**4. Topic value (€)**

The total value of this work package shall not exceed:

**€ 500,000**  
**[Five hundred thousand Euro]**

Please note that VAT is not applicable in the frame of the CleanSky program.

## Topic Description

CfP topic number	Title	Start date	T0
JTI-CS-2013-02-SAGE-02-034	Health Monitoring - Wireless Sensors	End date	T0 + 30 months

### 1. Topic Description

#### Main goals

The SAGE2 Demonstration Project aims at designing, manufacturing & testing a Counter-Rotating Open-Rotor Demonstrator. It involves most of the best European Engine & Engine Modules & Sub-systems Manufacturers.

Monitoring such an engine requires new technologies, new kind of surveillance and then new sensors.

Removing wires is key driver if the number of sensors increases

The aim of this Call For Proposal is to build wireless sensors prototypes adapted to aircraft engines and to demonstrate their ability to work in this harsh environment.

#### **1) OBJECTIVES**

The following sections define what is expected in this CFP. It must be noticed that the objectives can be discussed if all requirements cannot be addressed.

#### **1.A) Measure**

Measure calibration, conditioning, filtering (if applicable), analogical-numerical conversion system (if applicable) and everything required to measure the value of a physical parameter shall be addressed.

Physical values to measure are defined below.

*General remark: all the following ranges are target values. A candidate that cannot answer all of them can make a proposal of its best capabilities: these constraints (and the way to demonstrate the sensor can resist from them) can be discussed*

#### **1.A.A PRESSURE**

-1.A.A.A) Air pressure measure in a fixed area

-range: [0 ; 10 bar]

-resolution: < 10 mbar (objective) // < 100 mbar (requirement)

-accuracy < 0,2% full scale within the whole pressure range (objective) // <2% (requirement)

-repeatability <20 mbar (objective) // < 200 mbar (requirement)

-environment

-sensor shall survive to T range [-70°C; +300°C]

-P: [0;15 bar]

-1.A.A.B) Pressure measure in harsh environment (air/oil)

-range: [1; 30 bar]

-resolution < 25 mbar (objective) // <300 mbar (requirement)

-accuracy < 0,5% full scale within the whole pressure range (objective) // <2%(requirement)

-repeatability < 50 mbar (objective) // <300 mbar (requirement)

-particular constraint: no air flow disturbance due to the sensor

-environment

-sensor shall survive to T range [-70°C; +350°C]

**Clean Sky Joint Undertaking**  
**SP1-JTI-CS-2013-02-SAGE-02-034**

-P: [1;36 bar]

**1.A.B TEMPERATURE**

-1.A.B.A) Air Temperature measure in a casing

- range: [-10°C ; + 300°C]
- resolution < 3°C
- accuracy < 2% full scale within the whole temperature range
- repeatability <6°C
- environment
  - sensor shall survive to T range [-70°C ; +300°C]

-1.A.B.B) Temperature measure in a rotor

- range: [-10°C ; 250°C]
- resolution < 3°C
- accuracy <2% full scale within the whole temperature range
- repeatability <6°C
- environment
  - sensor shall survive to T range [-70°C ; +300°C]
  - centrifugal force : [0; 11500 m/s<sup>2</sup>]

**1.A.C STRAIN**

-1.A.C.A) Static measure on a strut element

- where: in a connecting rod
- range: [0; 400 MPa]
- resolution < 4 MPa
- accuracy < 2% full scale within the whole strain range
- repeatability <8MPa
- environment
  - sensor shall work on T range [-40°C; +160°C] and survive to T range [-70°C ; +250°C]

-1.A.C.B) Dynamic strain measure on a rotating casing

- where: in a metallic rotating casing
- range: +/- 200 MPa at [10Hz ; 5kHz]
- resolution < 1 MPa
- accuracy < 1% at 1 kHz
- repeatability <4MPa
- environment:
  - sensor shall survive to T range [-70°C ; +300°C]
  - centrifugal force : [0; 11500 m/s<sup>2</sup>]

**1.A.D FOR ALL SENSORS**

-Sensors shall be able to comply (no demonstration is required but there must be no particular obstacle) with:

## Clean Sky Joint Undertaking SP1-JTI-CS-2013-02-SAGE-02-034

- Electromagnetic Interference certification rules as defined in DO160G,
- lightning effects as defined in ARP5416
- the following maximum vibrations environment

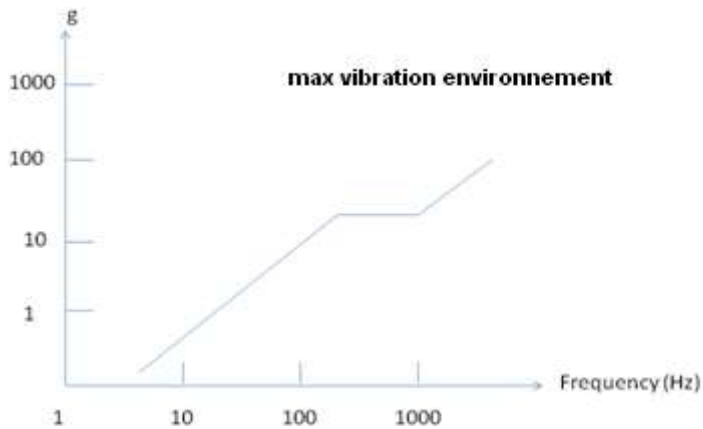

*Note: Given environments are maximum environments. Minimum environments in term of vibration, temperature, pressure, etc. will be given upon request.*

All these sensors shall be studied but it will be accepted to limit the number of prototypes: at least 1 kind of prototype sensor is required at T0+18 months and 2 different kinds of prototype sensors for the end of the project. Among the 2 minimum final prototypes, there must be at least 1 rotating and 1 non rotating sensor, among them a strain sensor (For example it could be a rotating dynamic strain sensor + a pressure measure in a fixed area or a static strain sensor + temperature sensor in a rotor or any other combination)

### **1.B) Local “intelligence”**

All treatments requested to extract embedded indicators (for instance sampling)

### **1.C) Wireless Power supply**

-The main concern is how to locally supply the sensor. For example it can be a wireless energy supply or energy local harvesting.

The source of Energy will depend on the need of sensors used and will be defined with the technical leader. Thermic, vibrations, pressure, etc. could be possible sources.

-Energy storage: Energy harvesting cannot be permanent, so local energy storage is required

-Cells are accepted if they can be safely embedded and answer maintenance constraints (For Line Replaceable Units no more than 1 time each 3 months and not more than 1 time each 5 years for other equipment).

### **1.D) Data transmission**

Sensors can send data to an embedded receiver, to another sensor or to a ground receiver that can be approached to the sensor by an operator. The data transfer method will be selected jointly by the partner and the project leader during the project based on partner proposal.

### **1.E) Sensors networks**

The added value of sensors network will be studied: Data transfer, storage optimisation, diagnostic, etc.



**1.F) Integration**

- Integration of the whole wireless measurement system (including the emission system but also the reception system). A specific study of the packaging shall be led.
- Test: the partner shall test and verify the complete system.

**2) CONSTRAINTS**

**2.a) Mounting**

Sensors are mounted on a metallic or composite element, on static or on rotating part, in oil, fuel or air environment.

**2.b) Transmission**

All the required sensors are intended to be installed in an aircraft engine. The metallic environment of a sensor mounted on an engine shall be highlighted. Details of metallic environment will be given upon request

**2.c) Overall dimension**

The maximum overall dimensions and installation constraints will be defined before the project kick-off.

**Task List. Engine Mounts System**

*Task 0: Management*

**Time Schedule & Workpackage Description:**

- The partner is working to the agreed time-schedule & work-package description.
- Both, the time-schedule and the work-package description laid out in this Call shall be further detailed as required and agreed at the beginning of the project.

**Progress Reporting & Reviews:**

- Quarterly progress reports shall be provided by the partner, referring to all agreed workpackages, technical achievement, time schedule, potential risks and proposal for risk mitigation.
- Monthly coordination meetings shall be conducted via telecom.
- The partner shall support reporting and agreed review meetings with reasonable visibility on its activities and an adequate level of information.
- The review meetings shall be held at the topic manager's facility.

*Task 1: State of the art*

For each item of §1.A->1.F, the partner shall establish the state of the art of in aeronautics and non-aeronautics areas.

A report will be provided.

*Task 2: Preliminary study*

-For each item of §1.A->1.F, the partner shall analyse project needs and will propose solutions. If an existing technology exists he can recommend it, and if no technology exists, he shall detail work plan.

-An activity report will be provided.

-Sensors limits shall be detailed and agreed during a milestone review at the end of task 2.

*Task 3 : Prototypes specifications & V&V plans*

-Prototypes specifications.

## Clean Sky Joint Undertaking SP1-JTI-CS-2013-02-SAGE-02-034

- V&V plan of the prototypes.
- Specification of the test requested.
- An activity report will be written.
- Limits shall be detailed and agreed during a milestone review at the end of task 3.

### Task 4: Prototyping

- The partner shall develop all the prototypes agreed in task 3
- The partner shall test the prototypes according to test plan defined in task 3 and if necessary adapt the prototypes.
- An activity report will be written.
- Limits of the prototypes/test conditions shall be detailed and agreed during a milestone review at the end of task 4.

*Note: it is accepted to limit the number of sensors prototyped: at this step 1 kind of sensor shall be prototyped and more is only an option.*

### Task 5: Integration

The partner shall integrate all the technical items agreed in task 4 to build complete wireless measurement systems and lead risk reduction tests.

The objective is 7 prototypes (2 temperature – 3 pressure – 2 strain) according to §1.A.

- An activity report will be written.
- Limits of the prototypes/test conditions shall be detailed and agreed during a milestone review at the end of task 4.

*Note: the wireless aspect includes the emitting but also the receiving system. Complete prototypes from the embedded measure to a value that can be used by the Topic Manager on its common system are expected.*

### Task 6: SAGE2 prototypes

The partner shall study how to integrate its prototypes into SAGE2 demonstrator with the help of Topic Manager, adapt the prototypes, and deliver them.

*Note: Tasks 5 and 6 can be led simultaneously but the end of task 6 is before the end of task 5.*

### Task 7: Final Technical report

The partner shall summarize in a report all its specifications, conclusions, test results, and everything useful to build a wireless sensor answering the need.

This report shall also include improvement recommendations.

### Task 8: Test support

The partner shall support the Topic Manager during SAGE2 tests of the sensors.

It includes installation, malfunction analysis and result analysis support.

## **2. Special skills, certification or equipment expected from the applicant**

- Experience in sensors is mandatory
- Experience in wireless technology is mandatory
- Experience in Energy harvesting and storage is mandatory
- Experience in aircraft engine instrumentation is an asset
- Experience in sensors network is an asset
- English language is mandatory

**Clean Sky Joint Undertaking**  
**SP1-JTI-CS-2013-02-SAGE-02-034**

**3. Major deliverables and schedule**

<b>Deliverable</b>	<b>Title</b>	<b>Description (if applicable)</b>	<b>Due date</b>
D1	State of the art	For each item of §1.A->1.E, the state of the art in aeronautics and non-aeronautics areas.	T0+1
D2	Preliminary study	For each item of §1.A->1.E: <ul style="list-style-type: none"> <li>- Detailed need analysis</li> <li>- Technology recommended or to develop and work plan</li> </ul>	T0+3
D3	Prototypes specifications & V&V plans	For each item agreed in task 2: <ul style="list-style-type: none"> <li>- Prototypes specifications</li> <li>- V&amp;V plans</li> <li>- Test bench specification</li> </ul>	T0+7
D4	Prototyping	For each item agreed in task 3: <ul style="list-style-type: none"> <li>- Prototypes design (prototype of at least 1 sensor is required)</li> <li>- Lab tests (partially representative conditions)</li> </ul> The deliverable is an activity report detailing each prototypes test results	T0+18
D5	SAGE2 prototypes	Integration study for SAGE2 demonstrator, and prototyping. Deliverables are a report and the prototypes.	T0+18
D6	Integration	-Integration of all technical items agreed in task 4 to make wireless measurement systems -Test of the complete prototypes The deliverables are: -prototypes of at least 2 different kinds of sensors are required (at least 1 rotating and 1 non rotating sensor, among them a strain sensor) -an activity report detailing each prototypes test results	T0+23
D7	Final Technical report	A final report including: -final specifications of each wireless measurement systems -test results -limits -improvement recommendations	T0+24
D8	Test Support	A test report including -malfunction analysis if applicable -results analysis	T0+30

**4. Topic value (€)**

<p>The total value of this work package shall not exceed:</p> <p><b>€ 1,000,000</b></p> <p><b>[One million Euro]</b></p> <p>Please note that VAT is not applicable in the frame of the CleanSky program.</p>
--

**Topic Description**

CfP topic number	Title		
JTI-CS-2013-02-SAGE-02-035	Non-rigid geometry variation simulation for fabricated aero engine structures	End date	T0 +24 months
		Start date	T0

**1. Topic Description**

The SAGE project aims at demonstration of engines and technologies to reduce fuel consumption, weight and increased efficiency of engine components. Within the objectives of open rotor development in SAGE2, RTD activities are underway on engine and component development including rotating turbine frames. The rotating frames developed within the SAGE2 project can be considered as engine critical parts, and therefore subjected to corresponding requirements and regulations as such.

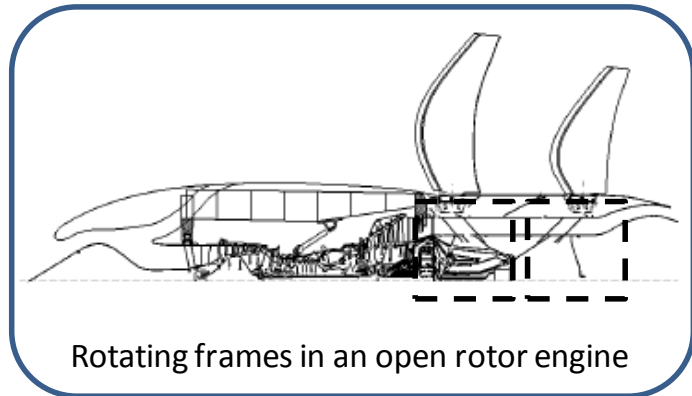

Rotating frames in an open rotor engine

It is currently foreseen that the rotating frames will be made in nickel based precipitation hardening superalloys. The two frames will be manufactured as weld assemblies in order to accomplish the future targets of light weight, cost efficient and reliable open rotor engines. In these weld assemblies there are narrow offset requirements in the weld seams. These requirements generally come from limitations in the lifing and the welding process itself. This often leads to narrow tolerance requirements on interfaces of parts in the assembly to make sure that final product requirements are fulfilled.

In traditional 3D variation simulation (stack-up's) it is common to consider that the parts are rigid. Often in production, forces are applied manually or by different fixturing solutions to assure that requirements on offset are fulfilled before welding parts together in an assembly. Depending on assembly sequences and geometry variation of incoming material, different fixturing forces need to be applied from component to component to assure the right fit in the seam before welding.

There are 3D variation simulation software capabilities today that consider non-rigid parts but they focus on sheet metal parts. In this project the main issue is to developed knowledge about castings and forgings together with sheet metal parts to define tolerances on ingoing parts and calculate forces needed in fixturing to assure final product requirements. A virtual and a physical demonstration of a weld assembly of a complex geometry component consisting of several rigid and flexible sub parts shall be performed. The demonstration must comprise a fixture solution that can vary the fixturing/clamping force. It is considered beneficial if the geometry assurance research can be complemented by weld distortion simulations.

The main deliverable is a 3D variation simulation methodology solving the stated problem above, verified to TRL 6 by a virtual and physical demonstration of capability. . The main benefit for the company is that the possibility to set the right tolerances and fixturing solutions increases in early phases in product development.

**Task 1: Management**

**Organisation:**

- The partner shall nominate a team dedicated to the project and should inform CfP Topic manager about the name/names of this key staff. At minimum the responsibility of the following functions shall be clearly addressed: Programme (single point contact with Topic Manager), Engineering & Quality.

## Clean Sky Joint Undertaking SP1-JTI-CS-2013-02-SAGE-02-035

### Time Schedule & Work package Description:

- The partner shall work to the agreed time-schedule (outlined in Part 3) and work package description.
- The time-schedule and the work package description laid out in this call shall be further detailed as required and agreed during negotiation based on the Partner's proposal.

### Progress Reporting & Reviews:

- Monthly one-page and quarterly progress reports in writing shall be provided by the partner, referring to all agreed work packages, technical achievement, time schedule, potential risks and proposal for risk mitigation.
- Regular coordination meetings shall be installed (preferred as teleconference).
- The partner shall support reporting and agreed review meetings with reasonable visibility on its activities and an adequate level of information.
- The review meetings shall be held quarterly either by WEBEX or at Topic Manager's premises or at the partner's premises.

### Task 2: Literature review and survey of non-rigid variation simulation

The first part of the project will be to thoroughly survey the scientific literature on existing methods considering non-rigid variation simulation. This review will serve as input to Task 3 below and should be reported and sent to Topic Manager for approval before proceeding to following task.

### Task 3: Virtual demonstration on non-rigid variation simulation

Within task 3 the aim is to virtually demonstrate capabilities in non-rigid variation simulation. The main activities in this task are to:

- Define suitable test case (component geometry, datums and fixturing strategy) together with the topic manager.
- Create models and meshes
- Assign material properties
- Assign variation from statistics of sub-component geometry variation and weld tolerance requirements supplied by the topic manager and (preferably) from weld distortion simulation.
- Perform variation simulation, Calculate forces needed to assure conditions before welding



### Task 4: Physical demonstration and validation

Manufacturing of component geometry and fixtures to be used in the demonstration of a weld assembly of a simplified (compared to attached photo) complex geometry component consisting of several rigid and flexible sub parts. The demonstration must comprise a fixture solution that can vary the fixturing/clamping force. Finally in this task the physical result is compared with the virtual demonstration.

### Task 5: Final assessment and recommendation

Within this task the project is finalized and a final report is written.

## **2. Special skills, certification or equipment expected from the applicant**

The CfP partner/consortium should have methods and knowledge considering non-rigid variation simulation. It is beneficial if the CfP partner/consortium have weld distortion simulation experience.

## Clean Sky Joint Undertaking SP1-JTI-CS-2013-02-SAGE-02-035

The CfP partner/consortium should have equipment, or an available supply network, for manufacturing of test specimens and fixtures used in physical tests (for example, equipment for performing automated (or semi-automated) welding on the demonstrator (robot TIG or Laser))

Experience in performing applied collaborative industrial research in international environment is considered as essential.

### 3. Major deliverables and schedule 24 Months

Deliverable	Title	Description (if applicable)	Due date
D1	Detailed Project Plan.	Task 1: Schedule with milestones.	T0 + 1
D2	Literature survey on non-rigid variation simulation.	Task 2: Literature review. Special focus on assembly of mix of rigid and flexible parts accounting for weld shrinkage compensation.	T0 +
M1	Define suitable test case and create models and meshes	Task 3: Virtual demonstration on non-rigid variation simulation	T0 + 8
D3	Report on variation simulation, weld assembly and fixture including clamping forces.	Task 3: Virtual demonstration on non-rigid variation simulation	T0+18
M2	Pre-test review	Task 4. Review of test objectives, test programme and test hardware prior to test.	T0+18
D4	Report of physical demonstration and validation of the virtual demonstration	Task 4: Physical demonstration and validation	T0 + 22
D5	Final report summarizing all results and findings within this WP.	Task 5: Final assessment and recommendation	T0 + 24

### 4. Topic Value (€)

The total value of this work package shall not exceed:

**€ 450,000**

**[Four hundred fifty thousand Euro]**

Please note that VAT is not applicable in the frame of the CleanSky program.

**Topic Description**

CfP topic number	Title	Start date	End date
JTI-CS-2013-2-SAGE-02-036	Non-intrusive Turbine Blade measurements	T0	T0+30

**1. Topic Description**

Blade fatigue problems are critical aspects in High Speed Turbine. Due to the high rotational speed, the pull-load on the blades results in a high static stress and deflection (LFC). In addition, Low Engine Orders (rotor unbalancing and misalignments) become particularly stronger and with unusual high-frequencies for LPT (also airfoil modes can be excited). Within this scenario it is crucial to avoid an excessive blade static stress and any critical resonance in the operative range.

In order to validate the SAGE2 Turbine mechanical design it is necessary to measure the static and dynamic behaviour of SAGE2 turbine bladed-disks. In particular, it is important to take advantage of the DEMO ground test to characterize the level of static deflection and dynamic response of the Turbine Blades. Unlikely, due to the DEMO layout and space limitations it will not be possible to mount a conventional rotating instrumentation (i.e. Strain Gauges) and hence non-contacting measurement techniques (i.e. tip-timing) are required for the mechanical validation.

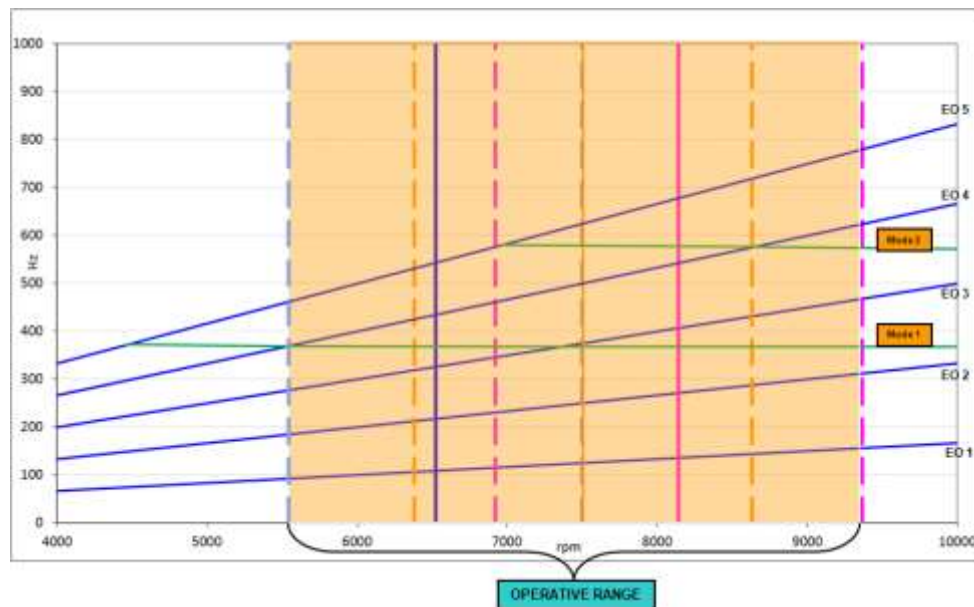

The objective of the proposal is to develop appropriate measurement techniques in order to characterize the blade static deflection and blade dynamic behaviour of the DEMO high speed turbine. The proposed activity is planned through the following steps:

WP1 - INSTRUMENTATION SPECIFICATION (M0 - M3)

Instrumentation specification. Numerical simulation of the expected blade deflection. Numerical identification and simulation of potential blade resonances of interests.

## Clean Sky Joint Undertaking SP1-JTI-CS-2013-02-SAGE-02-036

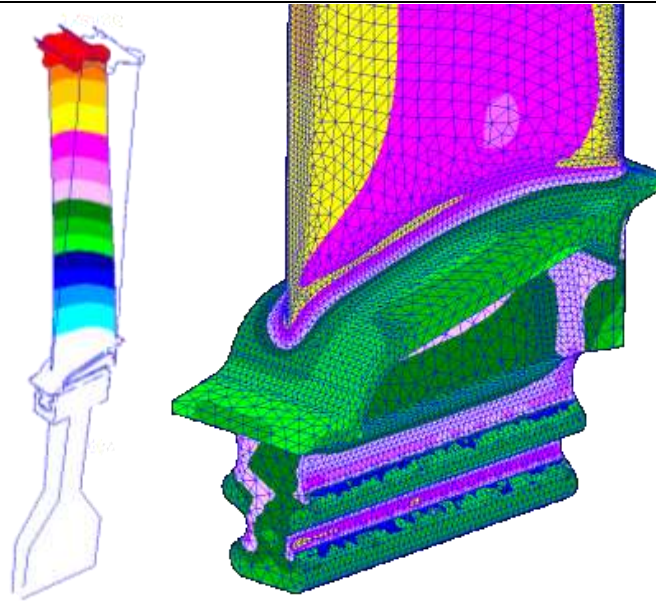

### WP2 - INSTRUMENTATION DESIGN (M3 - M15)

Based on the specification output of the WP1 the overall instrumentation system (probe kind, number, targeting, positioning, ...) has to be defined and adapted to the DEMO requirements and layout.

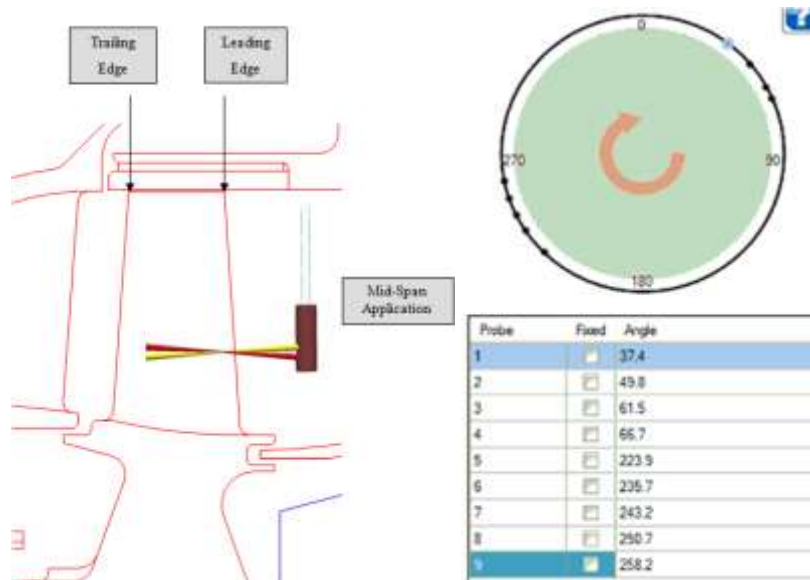

### WP3 - INSTRUMENTATION VALIDATION (M3 - M12)

Based on the results coming from WP 1 and WP 2, representative spin tests will be performed on DEMO scaled blade geometry in order to calibrate the measurement system. Strain-gauges will be also applied in parallel to validate the measurements.

The test will be performed in a dedicated Rig; the Rig itself, and the potential required adaptation, are part of the present Topic, and will be under the Applicant responsibility.

The Topic Manager will support the Applicant in case of Rig unavailability; the previous scenario is the preferred.



## Clean Sky Joint Undertaking SP1-JTI-CS-2013-02-SAGE-02-036

The scaled TA (SAGE 2 DEMO representative Blade Geometry) will be provided by the Topic Manager.

The Applicant must be responsible of the Instrumentation Validation test.

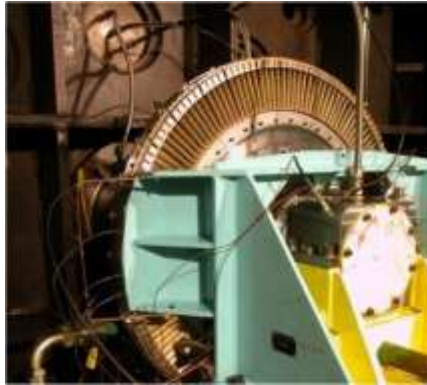

### WP4 - INSTRUMENTATION INSTALLATION INTO SAGE 2 GROUND ENGINE DEMO (M15 - M23)

The measurement system validated and calibrated at WP3 will be installed in the SAGE 2 DEMO engine for the blade deflection and vibration measurement.

The Applicant must:

- provide instrumentation installation schemes
- support the final instrumentation drawing release (overall module design under Topic Manager responsibility)
- provide the validated instrumentation and required assembly tools and cabling
- support the installation on the DEMO Engine

A full mechanical characterization of the high speed bladed-disk will be available after the ground tests. The developed instrumentation must be available for further test campaigns on the DEMO Engine, within the Clean Sky framework.

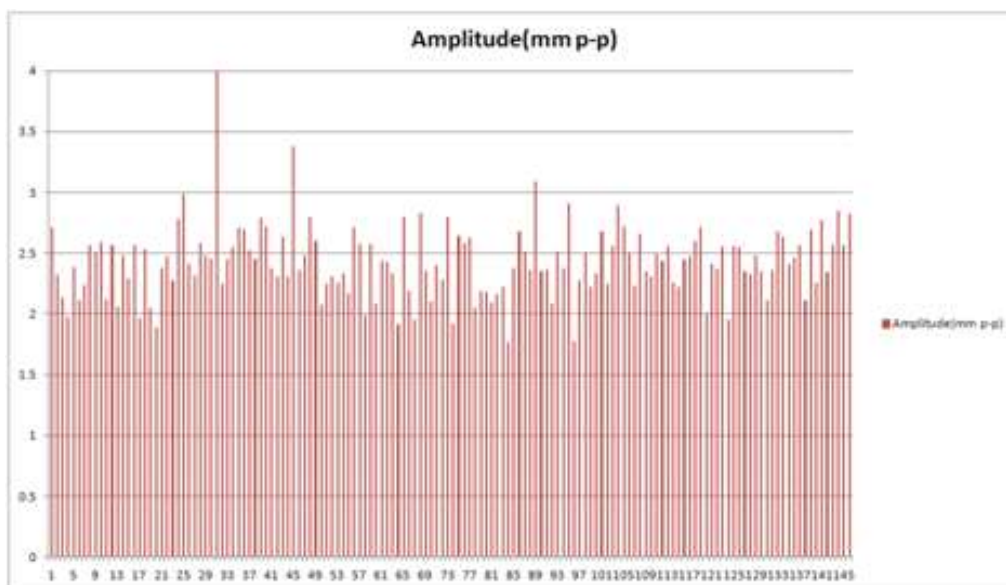

## Clean Sky Joint Undertaking SP1-JTI-CS-2013-02-SAGE-02-036

### WP5 - FINAL ASSESSMENT (M24 - M30)

The Applicant should support the SAGE 2 DEMO test campaign for the blades deflection and vibration measurement. A final assessment of the deflection and vibration behaviours of the DEMO will be performed. Tools and design practice will be updated as a consequence.

## 2. Special skills, certification or equipment expected from the applicant

### Necessary Equipment:

Extensive and proven experience in enhanced sensors (e.g. non-contacting measurement techniques), for aerospace products (in particular Pressure Turbine sub-modules), design, validation and manufacturing is mandatory.

Proven experience in aircraft engine and sub-modules (Pressure Turbines) instrumentation (design, validation and manufacturing) is mandatory.

Availability of technologies at a high readiness level to minimize program risks is an asset.

The Applicant needs to demonstrate to be in the position to have access to the test facilities required to meet the Topic goals.

Experience in Supply Chain management is mandatory.

Experience in aerospace R&T and R&D programs is a benefit.

The activity will be managed with a Phase & Gate approach and management plan has to be provided. The topic manager will approve gates and authorize progress to subsequent phases.

Technical/program documentation, including planning, drawings, design reports, risk analysis, FMEA, test plan and test requirements, test results, test analysis reports must be made available to topic manager.

## 3. Major deliverables and schedule

Deliverable	Title	Description (if applicable)	Due date
D1.1	DEMO Instrumentation Specification	Report on DEMO Instrumentation Specification	T0+3 (end of WP1)
D2.1	Instrumentation design/layout	Report on details instrumentation design & layout	T0+15 (end of WP2)
D3.1	Instrumentation validation on spintests	Report on instrumentation assessment on Spin Rig and potential design improvements (input for WP2)	T0+12 (end of WP3)
D4.1	Instrumentation Installation on Ground DEMO Engine	Report on instrumentation installation on Ground DEMO Engine	T0+23 (end of WP5)
D5.1	DEMO Mechanical Assessment	Final Report on SAGE 2 DEMO test campaign	T0+30 (end of WP6)

Milestones	Title	Description (if applicable)	Due date
M3.1	Availability of instrumented Spin Rig	Adapted Spin Rig available	T0+8
M3.2	Availability of instrumentation for Spin Rig Test	Instrumentation available	T0+9
M3.3 (under TM responsibility)	Availability of scaled TA (SAGE 2 DEMO representative Geometry)	TA available	T0+9
M4.1	Availability of validated instrumentation for DEMO Engine and assembly tools	Validated instrumentation and assembly tools available	T0+20
M4.2	Validated instrumentation assembled on DEMO Engine	Validated instrumentation assembled (DEMO Engine ready for testing)	T0+23

**Clean Sky Joint Undertaking**  
**SP1-JTI-CS-2013-02-SAGE-02-036**

**4. Topic value (€)**

The value of the project must not exceed:

**450,000 €**

**[Four hundred fifty thousand Euro]**

This topic value is a maximum gross value for the work package. Awards between 50% and 75% of this value may be made by the Clean Sky Joint Undertaking. Note that VAT is not an eligible cost in the context of this RTD activity.

**5. Remarks**

*The proposal of the applicant has to include maximal realizable values for every given requirement. A detailed work plan and time schedule is being expected. A profound financial plan must be attached as well. The applicant must fulfil the above mentioned requirements.*

**Topic Description**

CfP topic number	Title	Start date	End date
<i>JTI-CS-2013-2-SAGE-02-037</i>	Innovative instrumentation for rotating gauges	<i>T0</i>	<i>T0+12 months</i>

**1. Topic Description**

Aeronautical market evolution is focusing on mechanical transmissions as evidenced by the current fruitful research on the next generation engine (geared turbofan, open rotor, tilting rotor, ...). Open Rotor geared engine is a promising architecture for future aeronautical market due to significant reduction opportunities in fuel consumption compared to conventional engines.

The purpose of Geared Open Rotor demonstrator (SAGE 2) as part of the Sustainable and Green Engine (SAGE) platform is to advance the enabling technologies to achieve the necessary knowledge and validation.

The Geared Open Rotor architecture introduces a decoupling between the turbomachine speed and the propellers speeds to allow separate optimization of both systems, with overall efficiency gain of the whole engine, through the use of a Power Reduction Gearbox (PGB). Power Transmissions therefore enable this low emission novel engine architecture and represent a new core module.

Target applications require design solutions for very high power density. In addition, revolutionary configurations like Open Rotor integrates the PGB in a demanding temperature environment.

There is the need of exploring the possibility of apply latest available instrumentation (e.g. optical strain gauges, rotating acquisition systems, non-contact measurement) to maximize both learning from revolutionary application testing and design verification opportunities.

The present Call for Proposal supports the identification and implementation of innovative/advanced instrumentation into the Power Reduction Gearbox designed by the Topic Manager (SAGE 2, Work Package 2.2.8).

The partners work includes the following tasks:

**Task 1: Innovative Instrumentation Scouting (T0 – T0+5)**

Based on the definition of reference application(s) and relevant instrumentation requirements for the Power Gearbox (Applicant in conjunction with Topic Manager) a scouting of the potential solutions will be proposed by the Applicant.

The main areas of interest are:

- strain measurement of gear body, gear teeth and structural rotating parts;
- metal temperature measurement of gear body, gear teeth and bearing races;
- on-line oil analysis for oil degradation monitoring and indirect monitoring of transmission health status;
- vibration measurements;
- noise emission;

For rotating measurements, rotating acquisition units with post-test data download should be scouted as well.

The sensors will need to be developed taking into account the harsh environment of the PGB module positioning within the Engine (e.g. high temperature, high vibrations, aggressive oil,...)

The Applicant will identify and suggest potential solutions including system/sensors innovative and/or state of the art technology already used in other applications to be properly adapted.

The instrumentation proposal will be assessed during a dedicated Review by the Topic Manager through specific scorecards, and further shared with the SAGE2 Coordinator, to guarantee the potential feasibility of the integration into the Ground Demo Engine.

Based on the proposal and on the critical assessment made by the involved actors, the suitable instrumentation solutions will be selected.

## Clean Sky Joint Undertaking SP1-JTI-CS-2013-02-SAGE-02-037

The potential need of detailed Technology Maturation for some of the selected instrumentation solutions will be one of the parameters to be assessed. The Applicants should define detailed Technology Development Plans in order to guarantee and demonstrate the enough TRL of the proposed solutions (at least TRL5), to reduce the risk at an acceptable level and to guarantee the respect of the proposed project schedule.

### **Task 2: Instrumentation Procurement and Validation (T0+4 – T0+12)**

Based on the down-selected instrumentation (Task 1 final output), the Applicant will be responsible for the procurement of instrumentation prototypes for application during gearbox test on opportunity basis, and of the Technology Maturation process, if needed.

In case of Technology Maturation needs, the Applicant shall define a detail development process of the product, to be shared and assessed with the Topic Manager, guarantying full evidence of the TRL progress.

A proposal of the budget amounts that will be allocated to the procurement of instrumentation prototypes has to be presented by Applicant when replying to this Call.

## **2. Special skills, certification or equipment expected from the applicant**

Experience in Supply Chain management.

Extensive and proven experience in enhanced sensors (e.g. non-contacting measurement techniques), for aerospace / transmission systems products, design, validation and manufacturing is mandatory.

Availability of technologies at a high readiness level to minimize program risks is an asset.

The Applicant needs to demonstrate to be in the position to have access to the test facilities required to meet the Topic goals.

Experience in Supply Chain management is mandatory.

Experience in aerospace R&T and R&D programs is a benefit.

The activity will be managed with a Phase & Gate approach and management plan has to be provided. The topic manager will approve gates and authorize progress to subsequent phases.

Technical/program documentation, including planning, drawings, design reports, risk analysis, FMEA, test plan and test requirements, test results, test analysis reports must be made available to the topic manager.

## **3. Major deliverables and schedule**

<b>Deliverable</b>	<b>Title</b>	<b>Description (if applicable)</b>	<b>Due date</b>
D1.1	Potential Instrumentation Solution Down Selection	Critical assessment and down selection of scouted possible innovative solutions.	T0+4
D1.2	Technologies Maturation Plan	Detail technologies maturation plan for innovative technologies (if needed)	T0+5
D2.1	Final instrumentation List	Final instrumentation list, based on technology development output (if needed) or back-up solution choosing	T0+12

<b>Milestone</b>	<b>Title</b>	<b>Description (if applicable)</b>	<b>Due date</b>
M1.1 (under Topic manager Responsibility)	Instrumentation Requirements Definition	Definition of reference application(s) and relevant instrumentation requirements (Topic Manager in conjunction with Applicant)	T0+1
M1.2	Potential Instrumentation Solution Down Selection	Emission of D1.1 & D1.2 End of Task 1	T0+5
M2.1	Prototype Instrumentation Procurement	All Instrumentation to be validated available	T0+8

**Clean Sky Joint Undertaking**  
**SP1-JTI-CS-2013-02-SAGE-02-037**

**4. Topic value (€)**

The value of the project must not exceed:

**200,000 €**  
**[Two hundred thousand Euro]**

This topic value is a maximum gross value for the work package. Awards between 50% and 75% of this value may be made by the Clean Sky Joint Undertaking. Note that VAT is not an eligible cost in the context of this RTD activity.

**5. Remarks**

*The proposal of the applicant has to include maximal realizable values for every given requirement. A detailed work plan and time schedule is being expected. A profound financial plan must be attached as well. The applicant must fulfil the above mentioned requirements.*

**Topic Description**

CfP topic number	Title	Start date	TO
JTI-CS-2013-2-SAGE-02-038	Effect of tolerance variation in high power density gears	Start date	T0
		End date	T0+12M

**1. Topic Description**

Aeronautical market evolution is focusing on mechanical transmissions (Geared TurboFan, Open Rotor, next generation Turboprop, Tilting Rotor). Geared engines configurations are promising architectures due to significant reduction opportunities in fuel consumption compared to conventional turbofan engines.

These architectures introduce a decoupling between the turbomachine speed and the propeller(s) speed(s) to allow separate optimization of both systems, with overall efficiency gain of the whole engine, through the use of a Power reduction Gearbox (PGB). Power Transmissions therefore enable these low emission engine architectures and represent a core module.

A PGB design critical to quality is high power density, associated to high operative speeds. Today design definition is increasing product robustness by taking into account effect of manufacturing tolerances. This is of particular interest for hyperstatic conditions, which may be very sensitive to variations. In order to further validate design solutions for the PGB Module, the usage of a dedicated Design of Experiments (DOE) approach has been identified in support of specialized calculation tools.

The present Topic supports aims at performing dedicated experimental DOE.

The Applicant work includes the following tasks:

**Task 1: Test Plan Definition (M0 – M2)**

Task 1 covers the definition of an experimental test campaign supporting DOE approach validation.

The test campaign detail requirements will be shared by the Topic Manager to the Applicant, based on definition of reference geometry for the Test Articles (2 tooth geometries, spur gears), the expected output and the identified influencing factors, in order to assess and agree a DOE, based on which the Test Plan will be proposed by the Applicant.

For reference, the baseline DOE is: full factorial, 4 X's (2 levels). The X's parameters will be defined by the Topic Manager and agreed with the Applicant (M1.1 Test Campaign Requirements Specification)

**Task 2: Test Articles Procurement (M1 – M6)**

Task 2 covers the Test Articles procurement. Based on the agreed Test Plan and on the reference geometry for the Test Articles (issued by the Topic Manager) the Applicant will be responsible for:

- Manufacturing drawing(s) preparation
- Raw Materials procurement (material specification and quality control on Raw Materials to be supported by the Topic Manager)
- Test Articles machining
- Test Article heat treatment.

**Task 3: Test Campaign & Results wrap-up (M3 – M12)**

Task 3 covers the Test Campaign execution and results data analysis. Based on the agreed Test Plan and on the reference geometry for the Test Articles, the Applicant will be responsible for the Test Campaign, which includes:

- Rig Test adaptation (if needed), based on the Test Articles specification and on the Test Campaign definition
- Rig Test Commissioning
- Test Campaign (based on detailed Test Plan)
- Result wrap-up.

## Clean Sky Joint Undertaking SP1-JTI-CS-2013-02-SAGE-02-038

In particular the following effects (Y's) should be considered:

- a) load capacity (contact pressure, root bending stress)
- b) teeth wear (pitting, scoring/scuffing)
- c) noise (transmission error)
- d) power losses

Test results should be made available to the Topic Manager as long as they have been accrued and validated.

### 2. Special skills, certification or equipment expected from the applicant

**Necessary Equipment:**

- Power Recirculating Rig for gear component testing (bending, pitting, scuffing).

*Equipment has to be already commissioned and general description has to be presented by Applicant when replying to this Call.*

**Special Skills:**

- Experience in gear design and LTCA (for T/As design)
- Experience in Supply Chain management (for T/As procurement)
- Experience in experimental testing and Statistical Methodologies (for Test Plan definition and execution).

The activity will be managed with a Phase & Gate approach and management plan has to be provided. The topic manager will approve gates and authorize progress to subsequent phases.

Technical/program documentation, including planning, drawings, design reports, risk analysis, FMEA, test plan and test requirements, test results, test analysis reports must be made available to the topic manager.

### 3. Main deliverables and schedule

Deliverable	Title	Description (if applicable)	Due date
D1.1	Test Plan Definition	Detailed test plan definition, based on agreed DOE and identifying needed Test Articles	T0+2
D2.1	Test Articles Procurement Report	Report on the procured TAs	T0+6
D3.1	Results wrap-up	Experimental DOE validated results	T0+12

Milestone	Title	Description (if applicable)	Due date
M1.1 (under Topic manager Responsibility)	Test Campaign Requirements Specification	Definition of reference geometry, output and influencing factors, and design of experiment (Topic Manager)	T0+1
M1.2	Test Plan Definition	Emission of D1.1 End of WP1	T0+2
M2.1	Test Articles Procurement	Test Articles availability End of WP2	T0+6
M3.1	End of Test Campaign	End of experimental campaign	T0+10
M3.2	Final results wrap-up	Emission of D3.1 End of WP3	T0+12



**Clean Sky Joint Undertaking**  
**SP1-JTI-CS-2013-02-SAGE-02-038**

**4. Topic value (€)**

The total value of this work package shall not exceed

**€ 550,000**

**[Five hundred and fifty thousand Euro]**

Please note that VAT is not applicable in the frame of the CleanSky program.

**5. Remarks**

*The proposal of the applicant has to include maximal realizable values for every given requirement. A detailed work plan and time schedule is being expected. A profound financial plan must be attached as well. The applicant must fulfil the above mentioned requirements.*

**Clean Sky Joint Undertaking**  
**SP1-JTI-CS-2013-02-SAGE-03-024**

**Topic Description**

CfP topic number	Title	Start date	End date
<i>JTI-CS-2013-2-SAGE-03-024</i>	Electric Pump for Safety Critical Aero engine applications	<i>T0</i>	<i>T0+18 Months</i>

**1. Topic Description**

The SAGE3 project aims at development and demonstration of a large 3-shaft bypass engine Demonstrator. RTD activities are foreseen on developing electrically driven pumps to replace traditional mechanically driven variants in engine externals. The objective of the topic is to develop this technology and demonstrate to Technology Readiness Level (TRL) 6.

Pumping applications can include fuel, oil and other fluidic substances depending on the engine application. For the purposes of exploring the viability of electric pumping solutions, the oil system is chosen as the candidate fluid for this demonstration.

It would be advantageous for the partner to consider how the unit could be designed to operate in various locations within the engine, e.g. Core or fan case mounted with the associated implications in vibration and temperature environment.

**The Partner should read this topic thoroughly and when preparing a proposal take particular notice of section 5 of this document - Remarks**

The Partner shall in particular perform the following tasks:

**Task 1 Design and analysis of electrically driven oil pump**

The partner will work with the Topic Manager to agree a target specification against which to work. An outline of typical characteristics is included later in this section. Against this specification, the Partner will conduct the appropriate mechanical, electrical and electronic concept and detail design of both feed and scavenge elements of an oil pump suitable for deployment in a safety critical application within a large civil engine environment.

The Partner is expected to recommend new and novel pump configurations and will preferably demonstrate how the pump, associated electric motor and motor drive will interface to an Electronic Engine Controller. Whilst initial investigations into this technology have considered mechanically ganged multi-element gerotor based pumps driven through permanent magnet electrical motors, the partner will be expected to consider alternative solutions for each technology area. Strategies to ensure the correct synchronisation between individual pumping elements (e.g. between feed and scavenge in the oil application) should also be addressed.

The Partner will provide a detailed verification proposal for the new pump. The solution should be demonstrated to TRL6 (i.e. in an environment representative of an engine installation) and proposals should include a technology validation plan to show how this requirement will be met. If it is expected that the SAGE Members will contribute to the delivery of this plan then this should be highlighted.

Any material testing or manufacturing trials required to validate the design choices shall be carried out and reported by the Partner to the Topic Manager.

**Task 2: Electrically driven pump manufacturing and assembly**

The Partner will procure all materials and fittings and manufacture all material, test parts and components for rig testing necessary to support validation of the pump and support design and manufacturing technology.

It is expected that demonstration of the electrically driven pump technology will necessitate its' integration into a representative system demonstration or engine test. If it is agreed between the Partner and Topic Manager that such testing is required as part of the technology validation plan then the Partner will also be required to provide a number of additional parts for this testing. Proposals should indicate how this will be supported and identify specific features requiring this level of validation.

## Clean Sky Joint Undertaking

### SP1-JTI-CS-2013-02-SAGE-03-024

#### **Task 3: Electrically driven pump validation support**

The partner will conduct and report on all testing as necessary to ensure that the unit meets the specification requirements as appropriate to demonstrate compliance to engine environment TRL6.

If it is agreed that system demonstration or engine testing is required then the Partner shall support that testing through the preparation, test and appraisal phases. During any test facility build it is envisaged that on-site support will be required but on-call support would be acceptable during any testing that might be agreed. The Partner will supply all instrumentation necessary to validate the pump, motor and drive and components will be supplied already instrumented whenever possible.

#### **Task 4: Typical Electric oil pump operating environment**

##### **Temperature**

The unit should be capable of operation in a typical ambient environment of -55°C to 200°C.

##### **Vibration**

Consideration should be made of how the unit might operate within the vibration spectrum of a typical large aero engine.

##### **Compatible Fluids**

The pump will be designed to operate on a range of engine oils, demonstrated to have acceptable characteristics under engine operating conditions. The pump shall be capable of using and compatible with oil conforming to SAE AS5780 HPC and also be compatible with all oil brands qualified to MIL PRF-23699 F.

##### **Oil Pumping**

The Oil Pump assembly provides a flow of oil to the Engine components for cooling and lubrication with typical flow rates, temperatures and pressures as shown in the following table:

<b>Typical Feed Element Parameters</b>		MHD MTO Nominal Requirement	ISA MTO Nominal Requirement
<b>Inlet conditions</b>			
Inlet temperature	°C	172	152
Inlet Pressure	psia	25	26
<b>Flows</b>			
Pump flow at Pump inlet temperature	IGPH	1864	1801
Pump Discharge pressure (max)	psia	332	360

MHD – Maximum Hot Day; ISA – International Standard Atmosphere; MTO – Maximum Take Off; IGPH – Imperial Gallons per Hour

## Clean Sky Joint Undertaking SP1-JTI-CS-2013-02-SAGE-03-024

### Sumps to be scavenged

The Oil Pump assembly provides a means of scavenging oil mixed with entrained air from multiple locations with typical characteristics as shown in the following table:

Typical Scavenge Element Parameters			MHD MTO Nominal Requirement	ISA MTO Nominal Requirement
Inlet temperature	°C	Chamber #1	154	136
		Chamber #2	230	222
		Chamber #3	182	163
		Chamber #4	182	165
		Chamber #5	148	127
		Chamber #6	142	110
		Chamber #7	124	96
		Chamber #8	154	132
		Chamber #9	205	193
Nominal Scavenge Flow	IGPH	Chamber #1	414	408
		Chamber #2	529	494
		Chamber #3	145	135
		Chamber #4	112	103
		Chamber #5	73	70
		Chamber #6	140	140
		Chamber #7	92	92
		Chamber #8	110	110
		Chamber #9	443	506
Nominal Volumetric Air/Oil Ratio		Chamber #1	3	3
		Chamber #2	4	4
		Chamber #3	4	4
		Chamber #4	4	4
		Chamber #5	7.5	7.5
		Chamber #6	2.5	2.5
		Chamber #7	2.5	2.5
		Chamber #8	3	3
		Chamber #9	1.8	1.8
Nominal Total Volumetric Flow	IGPH	Chamber #1	1654	1631
		Chamber #2	2646	2470
		Chamber #3	723	674
		Chamber #4	559	515
		Chamber #5	621	592
		Chamber #6	490	490
		Chamber #7	322	322
		Chamber #8	440	440
		Chamber #9	1241	1416
Pump Inlet Pressure	psia	Chamber #1	21	21
		Chamber #2	127	152
		Chamber #3	127	152
		Chamber #4	127	152
		Chamber #5	48	56
		Chamber #6	20	22
		Chamber #7	20	22
		Chamber #8	20	22
		Chamber #9	20	22
Pump Discharge Pressure	psia	Chamber #1	48	50
		Chamber #2	48	50
		Chamber #3	48	50
		Chamber #4	48	50
		Chamber #5	48	50
		Chamber #6	48	50
		Chamber #7	48	50
		Chamber #8	48	50
		Chamber #9	48	50

**Clean Sky Joint Undertaking**  
**SP1-JTI-CS-2013-02-SAGE-03-024**

**2. Special skills, certification or equipment expected from the applicant**

Extensive experience in the detail design, development, manufacture and validation of electric drives and pumping technologies. In-service operation of aerospace applications would be advantageous. Experience of suitable quality control systems is essential.

Successful experience, with demonstrable benefits, of application of innovative manufacturing and material technologies to reduce weight and cost of parts is an asset. Availability of technologies at an high technology readiness level to minimise programme risks is an asset.

Experience in R&T and R&D programs. Experience of aerospace related research programs would be an advantage.

The Partner needs to be in the position to have access to the manufacturing facilities suitable for making an agreed set of equipment suitable for system integration or engine test if required.

The Partner needs to have access to rig test facilities for vibration & thermal endurance testing.

The activity will be managed with a Phase & Gate approach and management plan has to be provided. The Topic Manager will approve gates and authorise progress to subsequent phases.

Technical/programme documentation, including planning, drawings, manufacturing and inspection reports, must be made available to the Topic Manager.

**3. Major deliverables and schedule**

Deliverable	Title	Description (if applicable)	Due date
D1.1	Electric oil pump launch and concept review	Participate in launch review for project	T0+1
D1.2	Electric oil pump technical specification	Agreed specification against which to continue project	T0+4
D2.1	Electric oil pump Prelim Design Review		T0+6
D2.2	Electric oil pump Critical Design Review		T0+10
D3.1	Launch manufacture of tech demo hardware for validation testing		T0+16
D3.2	Deliver validation hardware		T0+17
D3.2	Validation testing		T0+18
D4.1	End of validation testing report issued		T0+18

**4. Topic value (€)**

The value of the project shall not exceed:

**1,750,000€**  
**[One million seven hundred and fifty thousand Euro]**

This topic value is a maximum gross value for the work package. Awards between 50% and 75% of this value may be made by the Clean Sky Joint Undertaking. Note that VAT is not an eligible cost in the context of this RTD activity.

## 5. Remarks

***Content of the proposal (including these items will significantly enhance the proposal)***

- a) *A clear and precise budget breakdown should be provided, outlining spend in all areas of the programme (human resource, outsourcing, materials, capital spend, etc.)*
- b) *A detailed Risk Assessment – key programme, technology, material, manufacturing and budget risks.*
- c) *Detailed design and make plan with decision gates and contingency loops. The plan must include a clear material and feature selection process.*
- d) *The proposal must include details of material supplier agreements. Lead times for material delivery, quantities, costs, contingencies, etc. should be indicated.*
- e) *The proposal should include ROM estimates for unit cost and weight.*
- f) *Verification of successful manufacture. Requirement to demonstrate in proposal how the Partner would ensure a unit is acceptable for useage within the engine conditions listed.*
- g) *The partner should identify key certification drivers from appropriate regulatory bodies (eg. EASA CS-E) and show how compliance with those requirements will be demonstrated*
- h) *Partner to suggest any parts of the manufacture process that could be improved / automated for main line unit delivery.*
- i) *Partner to suggest how the technology under development could be applied to other market sector, and also how existing technology developments from other market sectors could be usefully adapted to meet the specific needs of this opportunity.*

**Topic Description**

CfP topic number	Title	Start date	T0
JTI-CS-2013-2-SAGE-03-026	High bypass ratio fan capability acquisition	End date	T0+12

**1. Topic Description**

The SAGE3 project aims at development and test of a large 3-shaft bypass engine Demonstrator. In order to get higher propulsive efficiency and lower fuel consumption and noise, low pressure ratio, high by-pass ratio turbofans are considered as an optimum solution. In order to de-risk the development of the SAGE3 demonstrator and to support engine data appraisal activities, RTD activities are focused on engine-representative rig tests covering the pressure-mass flow envelope characteristic of the high bypass, low pressure-ratio turbofan. Rig test data are essential to carry out comprehensive fan performance and noise measurements and providing a solid basis for SAGE3 demonstrator fan design evolution and experimental data acquisition. At a European level such test capabilities targeting the required pressure ratios and mass flows are not available; the scope of the topic is to acquire the capability to test such high bypass ratios in engine representative rig facilities prior to the demonstrator test.

The rig tests will cover aero, noise and operability of a very high bypass ratio (VHBPR), engine-representative fan under low- and high-power conditions. Fan performance (rotor and stage), flutter and noise (forward/rearward arc, modal analysis) will be part of the outcomes of the test. RTD activities funded by this CfP are focused on the support of test capability acquisition aimed to cover high bypass ratios and low pressure ratios for such tests. The actual work required will depend on the initial capability of the facility and its modularity. However, this work package will define the maximum resources to be allocated and the timescales required for the implementation.

**The Partner should read this topic thoroughly and when preparing a proposal take particular notice of section 5 of this document - Remarks**

The Partner shall in particular perform the following tasks:

**Task 1 – preliminary study**

The Partner will conduct a preliminary feasibility study to increase rig test facility capabilities and achieve mass flows and pressure ratio given below.

The Partner will present a detailed time-cost-resource analysis with timescales compatible with the deliverables listed in a following section.

First indication of the requirements in terms of mass flow function vs fan system pressure ratio are given in the table below.

Concerning noise requirements, the facility owner should demonstrate that the test rig equipment will produce broadband noise levels well below (e.g. 10 dB and more) the predicted forward and rearward propagating broadband fan noise of any test aimed to de-risk the SAGE3 demonstrator programme (i.e. induct broadband OAPWL 130 dB for the rig). Required mass flow rates and maximum noise levels for the facility will be agreed by the Topic Manager and the Partner as soon as more data concerning the facility is made available by the applicant.

Pressure ratio	Mass flow function (WRTP)
1.1	150
1.2	230
1.3	270
1.4	300

## Clean Sky Joint Undertaking SP1-JTI-CS-2013-02-SAGE-03-026

### **Task 2 – detailed design and implementation**

The Partner will conduct the detailed design and make activities targeting the test requirements specified in Task 1 and in line with the preliminary design. The Partner will be responsible to select and sub-contract suppliers (if any) and monitor that their activities are in line with the time scale given in the work package. The partner will be responsible for manufacturing and/or procuring the hardware with adequate quality, mechanical performance and endurance.

### **Task 3 – validation and buy-off**

The Partner will agree with the Topic Manager the validation strategy to prove that requirements specified in Task 1 are met. A rig fan test as part of the SAGE3 test activities will be used in support of the validation strategy. The partner will be responsible to select and sub-contract any supplier needed to perform the test and related measurements as agreed with the Topic Manager. Results will be available to the topic manager who will buy-off the upgrade. on basis of the requirements specified in Task 1 and actual results from the pass-off test.

## **2. Special skills, certification or equipment expected from the applicant**

The Partner supporting the test should have a large experience in testing fan systems (including intake, bypass duct, splitters and bifurcations) under engine representative geometries (OGV numbers, bypass duct configuration, etc.), scales (about 1:1 for small commercial engines and about 1:3 for large commercial engines) and fan blade tip relative Mach numbers and non-dimensional mass flows. In particular, noise test requires the capability to run the rig in clean bypass duct (i.e. just fan and OGVs, w/o any bifurcations and splitters) configuration for uncontaminated fan tone and broadband noise assessment. The facility requires extensive hardware and instrumentation for:

-fan performance: air meter for accurate inlet mass flow calculation, pressure/temperature rakes for stage efficiency and fan mapping

-fan flutter: rotor telemetry for fan instrumentation (e.g. strain gauges, tip timing, tip stagger measurements), in-duct, wall flushed pressure transducers (synchronised with the rotor blade instrumentation)

-fan noise: in-duct pressure transducers spread across the whole fan/bypass duct system, in-duct pressure transducers arranged in rings upstream and downstream the fan system and the bypass duct for acoustic mode analysis

Additionally, the rig test facility needs to be a two-stream rig and should present a modular architecture aimed to test different configurations (e.g. number of ESSs, OGVs, bypass duct configurations, etc.) without removing the rig from the facility.

Due to the noise test requirements set for the oncoming tests supporting the SAGE3 demonstrator programme, outdoor facilities cannot be considered.

The Partner needs to have a demonstrable experience in running design and make activities with external suppliers.

The activity will be managed with a 'Phase & Gate' approach and management plan has to be provided. The Topic Manager will approve gates and authorise progress to subsequent phases.

Technical/program documentation, including planning, drawings, manufacturing and inspection reports, must be made available to the Topic Manager.

## **3. Major deliverables and schedule**

<b>Deliverable</b>	<b>Title</b>	<b>Description (if applicable)</b>	<b>Due date</b>
D1.1	Preliminary upgrade study	Preliminary design of the rig test facility with time, cost & resource analysis. The deliverable also contains a preliminary assessment of the rig test facility performance in terms of flow rates and rig noise.	T0+2
D2.1	Detailed design	Final design of the facility – a detailed analysis of performance, noise and lifing will be made available to the Topic Manager	T0+6
D3.1	Upgrade pass off	Results of the pass off test as agreed with the Topic Manager to show the capabilities of the new rig test facility	T0+12
<b>Milestone</b>	<b>Title</b>	<b>Description (if applicable)</b>	<b>Due date</b>
M1	Rig CDR	Critical Design Review for the rig held	T0+6



## Clean Sky Joint Undertaking SP1-JTI-CS-2013-02-SAGE-03-026

M2	Rig test	Rig test in demonstration of rig capabilities completed	T0+11
----	----------	---	-------

#### 4. Topic value (€)

The value of the project shall not exceed:

**1,500,000 €**  
**[One million five hundred thousand Euro]**

This topic value is a maximum gross value for the work package. Awards between 50% and 75% of this value may be made by the Clean Sky Joint Undertaking. Note that VAT is not an eligible cost in the context of this RTD activity.

#### 5. Remarks

##### **Content of the proposal (including these items will significantly enhance the proposal)**

1. *A clear and precise budget breakdown should be provided, outlining spend in all areas of the programme (human resource, outsourcing, materials, capital spend, etc.)*
2. *A detailed Risk Assessment – key programme, technology, material, manufacturing and budget risks.*
3. *Detailed design and make plan with decision gates and contingency loops. The plan must include a clear material and feature selection process.*
4. *The proposal must include details of material supplier agreements. Lead times for material delivery, quantities, costs, contingencies, etc. should be indicated.*
5. *The proposal should include ROM estimates for unit cost and weight.*
6. *Verification of successful manufacture. Requirement to demonstrate in proposal how the Partner would ensure a unit is acceptable for usage within the test conditions listed.*
7. *The partner should identify key certification drivers from appropriate regulatory bodies (eg. EASA CS-E) and show how compliance with those requirements will be demonstrated*
8. *Partner to suggest any parts of the manufacture process that could be improved / automated for main line unit delivery.*
9. *Partner to suggest how the technology under development could be applied to other market sector, and also how existing technology developments from other market sectors could be usefully adapted to meet the specific needs of this opportunity.*

# Clean Sky Joint Undertaking

## SP1-JTI-CS-2013-02-SAGE-04-025

### Topic Description

CfP topic number	Title	Start date	TO
JTI-CS-2013-02-SAGE-04-25	Scouting high performance steels for gears and bearings		
		End date	TO + 18M

#### 1. Topic Description

The aeronautical market evolution is focusing to develop enhanced engine geared architectures, characterized by the presence of mechanical transmissions (Geared TurboFan, Open Rotor, next generation Turboprop, Tilting Rotor).

The Geared Turbofan (GTF) is one of the promising innovative architectures for the aeronautical market, due to significant reduction opportunities in fuel consumption compared to conventional engine architectures.

The Ultra High Bypass Technology has the potential for significant reductions in fuel burn, noise and emissions, and the GTF architecture can enable these benefits while allowing a reasonable engine and core size.

The GTF architecture introduces a decoupling between the turbomachine speed (power turbine) and the fan speed enabling a separate optimization of both systems, with overall efficiency gain of the whole engine, through the use of a Power reduction Gearbox (PGB), also named Fan Drive Gear System (FDGS), being the transmission placed between the Fan and the Low Pressure Turbine.

The FDGS is the heart of the difference between a GTF architecture and a conventional one, representing therefore a new engine core module.

The Topic Manager is responsible of SAGE4 WP4.2.1 developing a next generation FDGS that will be tested to validate envisaged performance leap and matured the implemented technologies.

For a Power Gearbox design one of the key Critical to Quality (CtQ) is the overall envelope (Power Density) to enable optimal integration into the engine and therefore an overall optimal engine performance.

Therefore there is a particular interest in applying innovative high strength materials.

However application to high power density and highly integrated components requires careful evaluation of material behaviour under main operative conditions (e.g. stress level, temperature, corrosion resistance, contamination).

The project is aiming at scouting up to three innovative high strength materials when used for gears and bearings (e.g. Pyrowear 675, CSS-42L...)

In order to answer the needs of the SAGE 4 in terms of research, technological development and demonstration activities, it is planned to offer individual task to the industry, universities or any legal entity. The present Topic supports the high load capacity gear's and bearing's materials implementation into the Fan Drive Gear System.

The Applicant work includes the following Tasks:

#### **Task 1: Specification and materials selection including surface treatment (M0 – M2)**

The Topic Manager and the Applicant will jointly scout the innovative high strength materials (up to three), suitable for both gears (proposal under Topic Manager responsibility) and bearings (proposal under Applicant responsibility), taking also into account the optimal surface heat treatment.

A final selection of the material(s) to be characterized will be jointly made by the Topic Manager and the Applicant, with respect to agreed criteria.

## Clean Sky Joint Undertaking SP1-JTI-CS-2013-02-SAGE-04-025

### **Task 2: Surface treatment and manufacturing trials** (M3 – M8)

Based on the material(s) and relative surface treatment selected in Task 1, and on a defined gear and bearing representative geometry, a campaign dedicated to validate the surface heat treatments and the manufacturing process has to be launched and followed by the Applicant.

The Topic Manager will support the Applicant in the definition of the components representative geometry, and will be responsible of the final validation of that geometry.

The final results of the trials will be validated in a jointly review by the Topic Manager and the Applicant.

### **Task 3: Bearings and gears specimen manufacturing** (M3 – M11)

Based on the output of Task 2 and on the geometry of the Gears and Bearings representative Test Articles, for both the testing activities (Gears and Bearings) the test articles procurement will be managed as follows:

- Raw materials procurement by the Applicant (material specification and quality control on Raw Materials to be supported by the Topic Manager)
- Test Articles machining managed by the Applicant
- Test Articles surface Heat Treatment by the Applicant (to be supported by the Topic Manager, following the process jointly identified in Task 1 and validated in Task 2)

The Gear Test Articles geometry will be defined by the Topic Manager.

Sets of bearings and gears for technological demonstration need to be in line with demonstration requirements (number of prototypes shall be adequate for statistical analysis of results).

### **Task 4: Bearings testing (endurance, contamination, low oil)** (M10 – M16)

Demonstration through experimental tests of bearing life improvements and oil contamination resistance, to be achieved through the usage of the identified material(s) (Task1). Execution of endurance and damage propagation tests shall be carried out by the Applicant.

The typology and number of experimental test need to be in line with development and demonstration purposes; the proposal and definition of the test plan is under the responsibility of the Applicant, and should be agreed with the Topic Manager.

### **Task 5: Gear testing (bending)** (M12 – M16)

Determination of bending fatigue limit of the innovative material selected in Task 1 through an optimized characterization process (i.e. STBF, Single Tooth Bending Fatigue, testing).

The number of experimental test needs to be in line with development and demonstration purposes; the proposal and definition of the test plan is under the responsibility of the Applicant, and should be agreed with the Topic Manager.

### **Task 6: Results wrap-up** (M14 – M18)

The results of Task 4 (Bearings Testing) and Task 5 (Gear Testing) will be assessed by the Topic Manager and the Applicant, in order to validate the material(s) allowable for Gears and Bearings, suitable for the Power Gearbox architecture proposed by the Applicant to be validated by the Engine representative test (TRL 6 target).

## **2. Special skills, certification or equipment expected from the applicant**

Necessary Equipment:

*Bearings:*

Extensive experience in development of bearings for high performance aerospace application. Proven experience in aerospace bearing development for equivalent applications.

Proven experience in application of bearing technologies to gears and integration of bearing design with gears.

Successful experience, with demonstrable benefits, of application of innovative technologies to gears is an asset.

Availability of technologies at a high readiness level to minimize program risks is an asset.

## Clean Sky Joint Undertaking SP1-JTI-CS-2013-02-SAGE-04-025

The Applicant needs to demonstrate to be in the position to have access to the test facilities required to meet the Topic goals.

Experience in aerospace R&T and R&D programs.

*Gears:*

Extensive experience in testing of gears for high performance aerospace application.

The Applicant needs to demonstrate to be in the position to have access to the test facilities required to meet the Topic goals (Single Tooth Bending Fatigue Rig)

Experience in aerospace R&T and R&D programs.

Special Skills:

- Experience in gear design and LTCA (for T/As design)
- Experience in Supply Chain management (for T/As procurement)
- Experience in experimental testing and Statistical Methodologies (for Test Plan definition and execution).

The activity will be managed with a Phase & Gate approach and management plan has to be provided. Topic Manager will approve gates and authorize progress to subsequent phases.

Technical/program documentation, including planning, drawings, design reports, risk analysis, FMEA, test plan and test requirements, test results, test analysis reports must be made available to Topic Manager.

### 3. Major deliverables and schedule

Deliverable	Title	Description (if applicable)	Due date
D1.1	Material(s) identification	Report on identified and selected material(s) to be validated on Bearings and Gears application	T0+2 (end of WP1)
D2.1	Surface treatment and manufacturing trials assessment	Report on surface treatment and manufacturing trials assessment for the selected material(s)	T0+8 (end of WP2)
D3.1	Test Article procurement	Report on procurement of the test articles for the innovative material characterization (Bearing & Gears)	T0+11 (end of WP3)
D4.1	Experimental Test Report (Bearings)	Report of experimental test to substantiate improved bearing life and low contamination sensitivity.	T0+16 (end of WP4)
D5.1	Experimental Test Report (Gears)	Report of experimental test to substantiate determination of Gears bending fatigue limit	T0+16 (end of WP5)
D6.1	Material design limits identification for Gears & Bearing	Report on selected material(s) design limits identification for Gears & Bearing	T0+18 (end of WP6)

Milestone	Title	Description (if applicable)	Due date
M3.1	Test Article procurement (Bearings)	Procurement of the test articles for the innovative material(s) characterization on Bearings	T0+9
M3.2	Test Article procurement (Gears)	Procurement of the test articles for the innovative material(s) characterization on Gears	T0+11

**Clean Sky Joint Undertaking**  
**SP1-JTI-CS-2013-02-SAGE-04-025**

**4. Topic value (€)**

The value of the topic shall not exceed:

**700,000 €**  
**[Seven hundred thousand Euro]**

This topic value is a maximum gross value for the work package. Awards between 50% and 75% of this value may be made by the Clean Sky Joint Undertaking.

**5. Remarks**

*The proposal of the applicant has to include maximal realizable values for every given requirement. A detailed work plan and time schedule is being expected. A profound financial plan must be attached as well. The applicant must fulfil the above mentioned requirements.*

**Topic Description**

CfP topic number	Title	Start date	T0
<i>JTI-CS-2013-02-SAGE-06-003</i>	Development of materials, processes, and means to enable the application of piezoelectric materials in aero engine controls.	<b>End date</b>	T0 + 24M

**1. Topic Description**

The SAGE6 project has launched an action to prepare for a lean burn combustion system demonstration, using a large, high bypass gas turbine engine.

Lean burn technologies will contribute to lower emission engines, particularly helping to reduce the aviation discharge of nitrous oxides. A key technology element within this demonstration will be the realisation of new sensing and control functions, and will also require present sensing and control functions to operate to more demanding performance and accuracy levels in harsher environments, whilst achieving significantly improved reliability and longer lives on wing. This engine will then undergo a range of experiments, including flight testing, to enable technology validation at the system / whole engine level and across the operational envelope.

In order to achieve these benefits it will be necessary to employ radically different engine control technologies. Piezoelectric technology has been identified as a potentially key technology in the implementation of several different areas of functionality in engine controls. In addition, in order to fully exploit engine level benefits from these novel controls piezoelectric components will need to be developed to be fully robust to these hostile, fluid wetted (and even fully immersed) environments.

This topic will develop and demonstrate the materials, encapsulation methods and manufacturing processes required to fully implement these piezoelectric sensing and control technologies. It supports the evolution of technologies emerging from the Clean Sky SAGE Compact Aerospace Sensors and Effectors project.

The partner shall in particular perform the following tasks:

**Task 1: Review and specification of appropriate controls functional, performance, and environmental requirements**

Future engine control functionality, performance, and environments will be reviewed and specific piezoelectric device requirements defined. Particular emphasis will be placed on the form of the devices, minimum performance requirements, and most extreme environmental requirements, including fluid exposure, heat soakback, and thermal shock.

**Task 2: Materials and processes identification, development, and laboratory demonstrations**

The devices identified in task 1 will require means to protect the active materials involved to ensure adequate functionality and performance are maintained throughout the operational life (including all extreme and emergency operating conditions) of the control systems.

This task covers identification of potential means to effect this protection, and the development of the materials involved and appropriate manufacturing and encapsulation processes.

This task also covers laboratory-scale manufacturing of test pieces; plus laboratory scale functional, performance and preliminary environmental testing. The test pieces will be thoroughly examined post testing to determine the effectiveness of the protection afforded the active materials. The purpose of this testing and examination is to demonstrate the solutions identified are sufficiently robust and practical to merit progression to task 3.

The materials and the test pieces manufactured will have to demonstrate compliance with typical engine environments expected on a SAGE future engine. Although this will vary from engine to engine, temperatures of the order of -56°C to greater than +200°C can be expected.

Finally sufficient test pieces will be manufactured and supplied to task 3.

## Clean Sky Joint Undertaking SP1-JTI-CS-2013-02-SAGE-06-003

### **Task 3: Accelerated and sustained environmental testing**

Active materials are inherently robust compared to most other device technologies, but still have a number of potential failure modes. The specific active materials and devices selected in tasks 1 and 2 will be examined for potential failure modes in the applications, forms, and environments identified in task 1.

A robust environmental test programme will be defined and executed to expose any inherent weaknesses in the selected materials, manufacturing processes and physical form of devices identified above over an extensive range of functional and performance testing. It is anticipated this testing will feature both accelerated testing techniques where appropriate, and sustained environmental testing as necessary.

Where appropriate, some test pieces may be tested to destruction.

### **Task 4: Post environmental testing functional, performance, non-destructive testing, and destructive test assessments.**

Active materials may suffer from deterioration at the molecular level, in addition to gross macroscopic effects.

After the particularly harsh test environment of task 3, all surviving test pieces will be subjected to functional and performance testing to map any deterioration that has occurred over the period of the testing.

After functional and performance testing, the test pieces will be further examined to investigate any deterioration or contamination that has penetrated the test pieces, and may affect the materials at a molecular level.

### **Task 5: Exploitation Plan**

Following completion of the above tasks, a plan will be generated showing the intended application of specific demonstrated environmentally robust piezoelectric devices and technologies to specific engine control functions to achieve the benefits of the Clean Sky programme. Establishing this linkage is considered critical to the success of the programme.

## **2. Special skills, certification or equipment expected from the applicant**

A strong aerospace background is considered essential in order to correctly identify appropriate functional, performance, and environmental applications and requirements.

It is recognised that the manufacture of piezoelectric devices, electrical attach means, and environmental protection technologies, require specialist skills and pedigree, and manufacturing and process equipment.

It is also recognised that very specialist materials groups and research institutions possess bodies of background experience and knowledge that will be particularly relevant to the execution of this programme of work.

Specific groups have also developed very specialist test technologies that may enable high value testing to be carried out in relatively short periods of time.

Clearly a range of environmental test facilities will be required, and specialist metrology may be required to accurately quantify performance and material degradation.

The partners need to demonstrate access to the full range of design, manufacturing, process, test, and analysis facilities required to meet the above goals.

The activity will be managed with a Phase & Gate approach and a management plan has to be provided.

## **3. Major deliverables and schedule**

<b>Deliverable</b>	<b>Title</b>	<b>Description (if applicable)</b>	<b>Due date</b>
D1	Requirements Specification	Specification of appropriate piezo devices functional, performance, and environmental requirements.	T0+3
D2	Test pieces and laboratory test results.	Test pieces will be designed, manufactured, and tested under laboratory conditions.	T0+12
D3	Environmental test	Full reports of the environmental testing, including functional and performance test results at conclusion of	T0+21

**Clean Sky Joint Undertaking**  
**SP1-JTI-CS-2013-02-SAGE-06-003**

	results.	testing.	
D4	Results of microscopic analysis.	Detailed description and analysis of the condition of the test pieces after environmental test, specifically detailing the scope of production applicability.	T0+22
D5	Exploitation Plan	A plan giving specific detail on future application of fully environmentally robust piezoelectric devices in aero engine fuel systems.	T0+24

**4. Topic value (€)**

The value of the project shall not exceed:

**1,500,000 €**  
**[One million five hundred thousand Euro]**

This topic value is a maximum gross value for the work package. Awards between 50% and 75% of this value may be made by the Clean Sky Joint Undertaking.



## Topic Description

CfP topic number	Title	Start date	TO
JTI-CS-2013-2-SAGE-06-007	Validated Design Methodology for Fuel Manifold Systems	End date	TO +24m

### 1. Topic description

The SAGE6 project aims to develop and demonstrate a productionised lean burn combustion system. This will enable substantially reduced pollutant emissions compared to current technology and support the future long term technology goals of the ICAO Committee on Aviation Environmental Protection (CAEP) as well as the future visions laid out in ACARE 2020 and Flightpath 2050.

One of the fundamental design features of lean burn combustion is the use of staged combustion technology where a lean burning main zone and rich burning pilot are used to create lower pollutant emissions without compromise to system operability. Amongst other things this creates the need for a more complex fuel delivery pipework system to control the fuel distribution to the different combustion zones, leading to increased complexity, space constraint and an increased requirement for mechanical integrity to avoid reliability reduction. These factors increase the need to ensure the mechanical integrity and particularly the vibration response of the system. Vibration can lead to high cycle fatigue cracks and component wear and therefore needs to be assessed during the design, product development and through the life of the machine.

Key enablers to meeting these requirements are:

- Validated design for fuel pipe systems
- Predictable resonance frequency
- Predictable amplitude in all modes
- Prediction within days during preliminary design
- Characterisation of mounts and pipes
- A clear understanding of excitation force
- Characterisation of bracketing and mounting
- The effect of fuel on system response.
- Extrapolation from test to operation
- Defined modelling approach
- Optimisation of design

The above enablers are currently not well characterised or understood for lean burn fuel systems. This work aims to address this through a programme of component, sub-system and full assembly testing and measurement in order to improve the understanding of system dynamic behaviour. This will be combined with a parallel modelling and validation work-stream that will deliver a validated design and analysis toolset suitable for use on future lean-burn engine design programmes.

The Partner shall in particular perform the following tasks:

#### **Task 1- Management**

##### **Organisation:**

The Partner shall nominate a team dedicated to the project and inform topic manager about the name/names of this key staff. There shall be a project manager who is the single point contact with topic manager.

##### **Time Schedule & Work-package Description:**

The Partner shall work to an agreed time-schedule & work-package description, being that laid out here, further detailed as required and agreed with topic manager at the beginning of the project.

##### **Progress Reporting & Reviews:**

Quarterly progress reports in writing shall be provided by the partner, referring to all agreed work packages, technical achievements, time schedules, potential risks and proposals for risk mitigation.

## Clean Sky Joint Undertaking

### SP1-JTI-CS-2013-02-SAGE-06-007

Regular coordination meetings shall be conducted via telecom or at topic manager company locations choosing with the Partner providing reasonable visibility on its activities and an adequate level of information.

The activities will be managed with a Phase & Gate approach. Topic manager will approve gates and authorise progress to subsequent phases.

The Partner shall submit a final report summarising the achievements, further requirements (if any) and articulating a route to commercial access thereby enabling widespread manufacturing using the capabilities developed.

#### **Task 2 Report on state of the art and recommendations**

The Partner shall study the relevant literature and report on the state of the art and its capabilities. The Partner will recommend new and novel methods for a validated design approach for pig-tail pipes on the combustion chamber casing.

#### **Task 3 Experimental characterisation of basic pipe assembly**

An experimental methodology will be developed to identify the dynamic behaviour of basic pipes, their mounts, clips and inserts. For each component the frequency response function, and the stiffness and damping behaviour will be reported.

Tests of the assembled basic components must be carried out by the Partner to identify the nonlinear dynamic response of the system. Source and significance of the detected nonlinearities must be evaluated.

An experimental investigation of the influence of pressurised liquids inside the pipes, and pre-stress due to the assembly process will be required.

Contactless full field linear and nonlinear operating deflection shapes must be measured for the validation of the suggested modelling approach.

#### **Task 4 Development of detailed model for basic pipe-mount assembly**

Detailed and accurate multi DOF 3D finite element models of the basic components must be created.

The partner will develop a fast and efficient approach to allow the prediction of the nonlinear forced response of the assembled pipe system within a design time scale.

A simple and computationally efficient modelling approach to include the effects of pressurised fuel and pre-stress in the pipes due to assembly must be introduced for a dynamic analysis of the system.

A model validation exercise must demonstrate the accuracy of the predicted nonlinear dynamic response of the assembly and the validity of the fuel and pre-stress models.

#### **Task 5 Operational level testing of fuel pipe sub assembly**

The partner will develop a representative subassembly setup of the pipe-casing assembly for large amplitude testing on a shaker system, including a realistic geometry, the correct excitation method, and the influence of the test rig on the results.

The nonlinear dynamic response of the developed subassembly must be measured at operational excitation levels, taking the influence of pressurised liquids inside the pipes, and pre-stress due to the assembly into account. An accurate measurement of the resulting stress fields must be provided to allow model validation.

The variability in the dynamic response of the subassembly, introduced by the uncertainty in the joints, must be quantified to improve the model validation results.

#### **Task 6 Development of a high fidelity modelling approach for fuel pipes on the casing**

The partner must expand the linear and nonlinear modelling approach suggest in task 4 to be used on large scale models of the fuel manifold subassembly and a full assembly, to enable an accurate prediction of the dynamic response.

A technique must be suggested how experimental results obtained from subassembly test on the shaker can be used to predict the operating deflection shape of the full assembly.

## Clean Sky Joint Undertaking SP1-JTI-CS-2013-02-SAGE-06-007

An effective approach to model the stress field on the full assembly must be provided and the predictions must be compared to obtained measurement data.

The predicted nonlinear frequency response results must be validated against the full field operating deflection shapes from task 5.

### **Task 7 Development of low fidelity modelling approach for fuel manifolds for preliminary design**

The partner will develop a fast and reliable modelling approach for low fidelity modelling of fuel pipes during preliminary design.

Implicit models for the mounts must be provided to allow the inclusion of stiffness and damping at an early stage during the design.

The models must be able to include effects of the fuel and pre-stress during assembly and must be able to predict the vibration amplitudes of the pipework within an acceptable range.

### **Task 8 Operational level testing of full casing assembly**

A test setup for a combustion chamber casing with all the pipe work attached (150kg) must be developed to allow base excitation at high amplitudes (15g) on a shaker-slip in a frequency range from 20-2000Hz.

A final full field non-contact nonlinear response measurement of the operating deflection shape at operating conditions must be provided to demonstrate the accuracy of the proposed modelling approach from task 7.

## **2. Special skills, certification or equipment expected from the applicant**

The applicant must have an existing capability and experience for fast and accurate nonlinear dynamic predictions of sub-assemblies with contact interfaces. The methods must be applicable for simple low fidelity models and highly detailed 3D finite element models.

The applicant must have demonstrated in depth experience in experimental techniques to characterise and identify the nonlinear dynamic behaviour of the pipe manifold assembly.

The applicant must have the relevant equipment and facilities to conduct the required tests. This includes a high amplitude shaking facility with a slip table to conduct operational level testing (15g) of large and heavy aircraft engine sub-assemblies (~150kg) over a wide frequency range (20-2000Hz) and a full field Scanning Laser Doppler Vibrometer system for the contactless operating deflection shape measurements.

The applicant needs to be in the position to have access to the manufacturing facilities suitable to produce the required test rigs for the project.

## **3. Major deliverables and schedule**

<b>Deliverable</b>	<b>Title</b>	<b>Description (if applicable)</b>	<b>Due date</b>
D1a, D1b,	Management report	2 reports will be written to summarise the project management of the programme, including deliverables, level of spend and dissemination	T0 + 12, T0 + 24,
D2	Report on state of the art	Literature review on testing and modelling of fuel pipes	T + 4
D3	Basic experimental pipe work characterisation	Experimental results of simple fuel pipe assembly at low level excitation	T + 9
D4	Basic modelling of simple fuel pipe setup	Validated modelling approach for basic nonlinear pipe assembly	T + 9
D5	Test techniques for subassembly measurements on shaker	Experimental test methodology for fuel manifold subassembly on shaker system	T + 18
D6	Detailed modelling technique for fuel manifold subassembly	Validated modelling approach for nonlinear large scale models, including fuel pressure and pre stress due to assembly	T + 18
D7	Low fidelity modelling approach for predesign stage	Simple and approximate models for full assembly modelling during predesign phase	T + 24

**Clean Sky Joint Undertaking**  
**SP1-JTI-CS-2013-02-SAGE-06-007**

D8	Operational level testing of full casing fuel manifold assembly	Testing methodology for full operational response levels of casing with mounted fuel manifold	T + 24
----	---	---	--------

#### 4. Topic value (€)

The value of the project shall not exceed:

**900,000 €**  
**[Nine hundred thousand Euro]**

This topic value is a maximum gross value for the work package. Awards between 50% and 75% of this value may be made by the Clean Sky Joint Undertaking.

#### 5. Remarks

**Content of the proposal (including these items will significantly enhance the proposal)**

- *A clear and precise budget breakdown should be provided, outlining spend in all areas of the programme (human resource, outsourcing, materials, capital spend, etc.)*
- *A detailed Risk Assessment – key programme, technology, material, manufacturing and budget risks.*
- *Detailed design and make plan with decision gates and contingency loops. The plan must include a clear feature selection process.*
- *The proposal must include details of supplier agreements and dependencies on sub-systems and access to IP held by third parties.*
- *The proposal should clearly describe the methods by which the Partner will demonstrate the validity of the proposed design approach for fuel pipe work.*

**Clean Sky Joint Undertaking**  
**Call SP1-JTI-CS-2013-02**  
**Smart Fixed Wing Aircraft**

## Clean Sky – Smart Fixed Wing Aircraft

Identification	ITD - AREA - TOPIC	topics	VALUE (€)	MAX FUND (€)
<b>JTI-CS-SFWA</b>	<b>Clean Sky - Smart Fixed Wing Aircraft</b>	<b>4</b>	<b>2.900.000</b>	<b>2.175.000</b>
<i>JTI-CS-SFWA-01</i>	<i>Area01 – Smart Wing Technology</i>		0	
<b>JTI-CS-SFWA-02</b>	<b>Area02 - New Configuration</b>		1.200.000	
JTI-CS-2013-02-SFWA-02-042	In-Service Monitoring of LE Contamination		250.000	
JTI-CS-2013-02-SFWA-02-043	Advanced measurement for low speed high scale CROR Wind Tunnel Test		950.000	
<b>JTI-CS-SFWA-03</b>	<b>Area03 – Flight Demonstrators</b>		1.700.000	
JTI-CS-2013-02-SFWA-03-013	Low speed Wind tunnel test for laminar wing demonstrator		1.000.000	
JTI-CS-2013-02-SFWA-03-014	Vibration reduction systems in pylon area		700.000	

## Topic Description

CfP Topic Number	Title	Start Date	End Date
<i>JTI-CS-2013-02-SFWA-02-042</i>	In-Service Monitoring of LE Contamination	<i>Jan-2014</i>	<i>Apr-2015</i>

### 1. Topic Description

The CleanSky Smart Fixed Wing Aircraft Integrated Technology Demonstrator (SFWA-ITD) consortium is interested in understanding the typical level of contamination and minor damage to a wing leading-edge in operational service.

Ideally this would include improved information about the rate of insect or other contamination and its currently unknown dependence on altitude, climatic zones, seasons and environment as well as the cleaning impact of flight through rain, or clouds and any impact of WIPS (Wing Ice Protection System) operation. In addition, the consortium would like to apply different surface treatments and examine the impact of these.

In this Call for Proposals topic, interested applicants are requested to install a camera on an aircraft that can view a section of the wing leading-edge. Camera recordings have to be made during regular operational flights and basic information about each flight has to be noted. These recordings have to be backed-up by specific leading edge inspections when appropriate.

The flights to be performed by the applicant could either be short-range (to increase number of flight cycles) or long-range (to increase operation in different climatic zones and seasons) or more preferably a mixture of both. The duration of the trial should be at least 6 months but will depend on the number of flight cycles and the type of aircraft.

Activities to be done by the applicant:

- Install an autonomous high resolution micro camera on an in-service aircraft that can view a section of the wing leading-edge (either a fixed leading-edge or the leading-edge of retracted slats). To ensure an adequate field of view it is proposed to install the camera in a fairing at the fuselage or the pylon.
- Select suitable camera equipment under consideration of the typical operating conditions during the flight.
- The viewing area should be about 500mm span by 250mm chord and the spanwise location should be defined to suit the camera choice and installation.
- Provide the camera and ensure camera view to be of suitable quality to be able to capture insect contaminations within the recordings. A minimum spatial resolution of about 4px/mm will be needed as typical insect residues of interest are in the sub-millimetre scale.
- Provide and install recording equipment that operates fully autonomously for the expected number of days away from the home base or until down loading of data is practically possible.
- Test and verify that the system will deliver the required information.
- Certify the system and required installations for flight.
- Record the view of the wing leading-edge during each flight. Camera to take pictures every 10-60 seconds during climb-out and descent and every 15 minutes during cruise.
- Record details about each flight, such as date, time, origin and destination, weather conditions during climb-out and descent, cloud level during cruise, use of WIPS, altitude when slats were retracted or deployed. Record current altitude for each image and ensure allocation of the altitude data to the recorded images. Time (GMT) and date to be inserted on the images.
- For a specific number of flights, to photograph the visible area and count number of insect contaminations to check against camera view.
- Record any cleaning activity performed during the trial period. There should be no manual cleaning of the observed area in addition to the regular cleaning periods in order to avoid non-representative data.
- Perform visual inspection of leading-edge section and record any scratches and gouges before commencement of trial, after every month, and at end of trial.

## Clean Sky Joint Undertaking SP1-JTI-CS-2013-02-SFWA-02-042

- First and final inspection of observed surface to be done together with Airbus specialists. Expected duration of about 2-3 hours.
- Application of different surface treatments as defined by SFWA partners.
- Collection of the recordings, data, photos and inspection results for post processing.

Support provided by SFWA consortium partners:

- Specification of the required information from the tests and inspections.
- New surface treatments to be applied.

### 2. Special Skills, Certification or Equipment expected from the Applicant

- The applicant should be able to provide a suitable aircraft operating a regular service.
- The applicant should have the capability to provide and install suitable camera equipment and recording devices on an aircraft.
- The applicant should be able to inspect the viewable area, apply surface treatments and collect the required data.

### 3. Major Deliverables and Schedule

Del. Ref. Nr.	Title	Description (if applicable)	Due
1	Camera and recording equipment installation proposal	Description and justification of the proposed camera installation, the recording equipment installation, the viewable area and the expected quality. Also expected aircraft routes during the trial period.	M0 + 3 M
2	Initial test of camera and recording equipment	Installation of the devices and testing to verify the viewable area, the quality and that the required data can be collected.	M0 + 6 M
3	Initial inspection results	Detailed inspection of viewable area before start of trial.	M0 + 6 M
4	Initial trial test analysis and recommendations	Report showing preliminary results and any recommendations or changes to ensure the success of the test.	M0 + 8 M
5	Trial results	All recorded data, flight information, photographs and inspection results collected from tests in a digital format.	M0 + 12 M
6	Final inspection results	Detailed inspection of viewable area at end of trial.	M0 + 12 M
7	Final report	Final report showing installation details, test procedure and flight information.	M0 + 15 M

### 4. Topic value

The total value of biddings for this work package shall not exceed

**250,000 €**

**[Two hundred and fifty thousand Euro]**

Please note that VAT is not applicable in the frame of the CleanSky program.

### 5. Remarks

*The applicant should be aware of restrictions and requirements for subcontracting within CFP contracts. The applicant may represent a consortium of bidders to cover the individual aspects of this proposal e.g. flight operations, camera provision, analysis.*

## Topic Description

CfP Topic Number	Title	Start Date	End Date
JTI-CS-2013-02-SFWA-02-043	Advanced measurement for Low Speed High scale CROR Wind tunnel test	12-2013	
			07-2014

### 1. Topic Description

Clean Sky is investigating the potential of Counter Rotating Open Rotor (CROR) engines addressing the aerodynamic performance and acoustic signature of such engines. In order to characterise the unsteady flow-field and validate the aerodynamic and acoustic toolsets it is essential to perform a wind tunnel campaign dedicated to advanced measurement techniques, including PIV (Particle image velocimetry), transition detection & simulation of full scale boundary layer conditions. For this work a low speed aero-acoustic Wind Tunnel (WT) Test has to be conducted with an existing rig. This task will also include any specific development or adaption of advanced diagnostics measurements (e.g. optical diagnostic or other measurement equipment for measurement of unsteady flow, acoustic fields), including calibration and qualification of the diagnostic system.

Specifications of the rig, which is provided by the SFWA CfP topic manager and which has to be equipped with one CROR engine, are as follows:

- Large scale CROR powered rig,
- 0,85m propeller diameter,
- One 425kW per shaft counter rotating engine (max total 708kW), requiring pressurized air with a maximum mass flow of 12kg/s at 70 bar pressure @ turbine entry,
- The rig is mounted on a suitable support structure with engine feed and return air.

The applicant shall propose and develop a suitable experimental setup for an advanced measurement campaign including the following major deliverables:

- **Wind on commissioning** of the rig in the test section, along with all hardware, interfaces and software to complete the planned test campaign.
- **3 days of productive PIV measurement** (24 productive hours of testing plus one day of setup for measurement techniques).
- **2 days of productive transition measurement** and development (16 productive hours of testing). IR camera and illumination source to be provided by the topic manager.

**Rig to Wind Tunnel Integration.** Due to the complexity of trying to achieve detailed flow-field measurements of rotating propellers in operational conditions it is considered essential that the advanced measurement systems are synchronised (time window=> 1µs) to the propeller via the tunnel sub systems.

The applicant should complete the integration of the rig specific systems into the wind data acquisition, control and processing systems. This integration should include all required post processing of the measurements including the conversion of the measured raw data (i.e. Millivolt measurements) to the final requested data delivery format. The applicant should perform all activities related to the rig control, safety, training and engineering support prior to, during and following the Wind Tunnel test campaign. The applicant should assume that up to 4 trips may be required (average duration 3 days for 2-3 people) to support the preparation of the test campaign.

During the test all rig specific instrumentation along with near field (in flow) and far field acoustic (out of flow) arrays will be measured. The applicant shall procure or hire any specialist equipment and consumables required to perform the task such as acoustic data acquisition systems, motor drive air supply, delivery and control.

The applicant shall test the model in a large low speed WT of their choice which shall cover the following conditions:

- Mach number  $\geq 0.22$ ,



## Clean Sky Joint Undertaking SP1-JTI-CS-2013-02-SFWA-02-043

- The tunnel should have an anechoic open test section for far field noise evaluation,
- The test section should be larger than 8m by 6m (width x height),
- The model test support shall be acoustically treated and allow variable yaw angles while keeping the propellers on the axis of rotation and out of the influence of the shear layer,
- The applicant shall apply advanced steady and unsteady acoustic measurement methods.

An innovative approach is requested in setting-up and operating the advanced measurement systems along with a fast data acquisition system able to record all unsteady pressures and balance data at high sampling rates with at least one day of storage capacity on the facilities local data acquisition system.

The applicant shall apply innovative acoustic, PIV and propeller transition measurements such that the CROR noise signature is captured both in the flow of the tunnel but also outside of the air flow, correlated to the PIV and transition measurements. Moreover the applicant must ensure that those measurements are synchronized with rig engines such that local open rotor flow physics could be correlated to the far field noise signature and the detailed flow-field around the CROR motor. In particular, the applicant shall provide innovative probes for flow measurements that minimize the influence of acoustic reflections and boundary layers on the measured signal.

All measured data will be Topic Manager ownership.

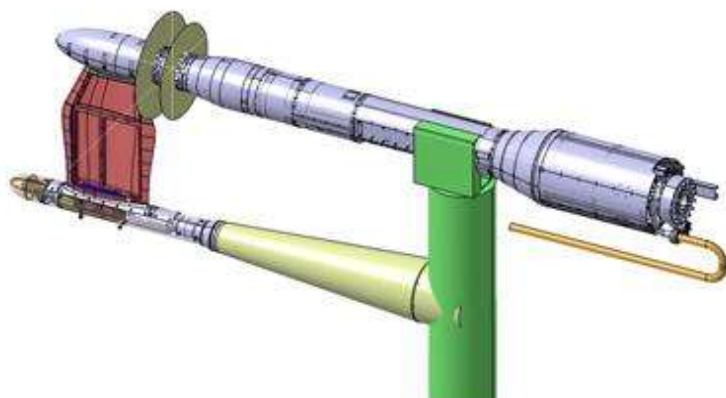

### 2. Special Skills, Certification or Equipment expected from the Applicant

Mandatory skills:

- Recognized skills in the field of PIV and transition detection on rotating equipment,
- Recognized skills in external aerodynamic & aero-acoustic experimental characterization,
- Recognized skills in aerodynamic steady and unsteady measurements, and in storing and processing of acoustic data,
- Availability of experienced tunnel staff ensuring high productivity testing, including model changes and operation of the pressurized engine simulators.

Mandatory equipment:

- Large low speed closed WT capable of Mach 0.22, with a test section greater than 8m wide and 6m high,
- Ability to supply the required mass flow and pressure to the rig,
- Advanced steady and unsteady acquisition and storage systems.

### 3. Major Deliverables and Schedule

Del. Ref. Nr.	Title	Description (if applicable)	Due
1	Rig and Advanced Measurement Technique Commissioning	Wind on commissioning of the rig in the test section, along with all hardware, interfaces, software and calibrations to complete the planned test Advanced Measurement Technique campaign.	M0 + 1M (min 1 month before start of Test)
2	WT Test	Complete description of the WT test campaign, including all	M0 + 1M

**Clean Sky Joint Undertaking**  
**SP1-JTI-CS-2013-02-SFWA-02-043**

	campaign description	activities related to model installation, rig integration, testing and model de-rig for 40 hours of productive testing (excluding the required wind on commissioning time, which is part of deliverable 1). This activity will also include all preparation, wind on commissioning and consumables required to perform a wind tunnel test campaign.	(min 1 month before start of Test)
3	Preliminary test data	Delivery of complete preliminary test database, including raw data, steady state data & dynamic data (including all PIV, transition detection & acoustic data) along with data processing and corrections.	M0 + 'x'M (continuously available during the test)
4	Final test data	Delivery of complete final test database, including raw data, steady state data & dynamic data (including all PIV, transition detection & acoustic data) along with data processing and corrections to the final data delivery format (TARDIS /LDF).	M0 + 'x'M (i.e. 1 month after the test)
5	WT Test Report	Test report to include full description of the experimental setup including a detailed run log and validated data description.	M0 + 'x'M (i.e. 1 month after the test)

**4. Topic value**

The total value of biddings for this work package shall not exceed

**950,000 €**  
**[Nine hundred and fifty thousand Euro]**

Please note that VAT is not applicable in the frame of the CleanSky program.

## Topic Description

CfP Topic Number	Title	Start Date	
JTI-CS-2013-02-SFWA-03-013	Low-speed Wind tunnel test for laminar wing demonstrator	12-2013	
		End Date	04-2014

### 1. Topic Description

#### Major objectives

Natural laminar flow wings will be flight tested, within a project called BLADE. A new outer laminar wing will be fitted on the legacy A340-300 wing from rib 27 onwards (see figure).

The wind tunnel test on BLADE demonstrator will deliver two major results :

- Inputs for the BLADE Flight Test Demonstrator flight clearance
- Know how for performing representative test for future laminar wings (from a wind tunnel test operations stand point, and from a technical V&V standpoint)

On the BLADE Flight Test Demonstrator, all leading edge slats will be passivated during flight tests: the new outer wing geometry & the slatless configuration imposed on the legacy wing are consisting in a new aerodynamic configuration for which CFD predictions demonstrated a significant gap between the legacy aircraft and the BLADE configuration in free air and in **ground effect conditions**. This triggers the need to perform a **back to back** wind tunnel test to feed the flight clearance process, and to tune flight control laws prior to flight test.

While CFD provides a suitable prediction for free air conditions until stall, wind tunnel test validation is required for ground effect conditions and the assessment of the stall angle, which are sizing for safety & operational flexibility (TOW, etc). For this purpose, BLADE project needs a wind tunnel test (WTT) facility with the right configuration & expertise allowing an adequate assessment (Reynolds number...).

Along with stall behaviour identification in ground effect, the wind tunnel test campaign will also serve basic longitudinal & lateral handling qualities characteristics measurements, validate some **leading edge device** (vortillon, Krueger) and also validate **ailerons & spoilers efficiency** at low speed, and limited **ice accretion** impact on handling (through artificial ice shapes testing).

#### Model characteristics

- The model is provided by Airbus.
- The model scale is 1/10.6, and 5,6 m full span.
- To allow ground effect testing a dorsal sting set up is required.
- The outboard wing is dismountable to allow back to back test between the legacy O/B wing and the laminar wing.
- Various flap setting will be tested.
- Leading edges devices will be fitted on the model.
- Simulated ice shapes will be fitted on the model.

#### The low speed Wind Tunnel characteristics and equipment

- The wind tunnel shall be capable to simulate ground effects with a level of representativeness in line with Airbus methods and processes.
- The wind tunnel test section shall be 8m > wide and 6m >high.
- The applicant is expected to provide the test facility , the associated services, and the measurements data in a format compatible with Airbus methods & processes
  - Note: the model will be ready & provided at the beginning of the test campaign. 1 day is provisioned for test set up installation (same amount of time for test set up removal)
- The test conditions will be centred around  $Me[0.2-0.3]$  and Reynolds number around 3 millions.
- Measurements will consist of forces, pressure & taps measurements.
- Results will be data in a format compatible with standard analyses of wind tunnel data by Airbus,

## Clean Sky Joint Undertaking SP1-JTI-CS-2013-02-SFWA-03-013

associated to photos & videos.

### Test campaign management

- The test campaign will be managed by an Airbus wind tunnel test engineer, in close cooperation with the wind tunnel test engineer from the applicant company.
- The wind tunnel operator will run test points provided by Airbus.
- About 170 to 200 wind tunnel test points are considered in the current test matrix, with the following varying parameters: Mach, incidence, sideslip, height above ground, high lift devices angles, ailerons deflections, spoilers deflections, tail (on or off), ice shapes.

## 2. Special Skills, Certification or Equipment expected from the Applicant

- Knowledge of Airbus wind tunnel test procedures & results format.
- Wind tunnel facility with measurements recording system.
- Mastering of technics for ensuring correct the laminar/turbulent transition to match test objectives.
- Mastering of test representativeness in ground conditions.

## 3. Major Deliverables and Schedule

Del. Ref. Nr.	Title	Description (if applicable)	Due
1	Preliminary wind tunnel test data	Preliminary data should be available in txt or Tardis format during the test soon after each run (including WT corrections). A list explaining the signification of the variables (WTT corrections, axis systems etc.) is requested.	M0 (end of the test)
2	Complete validated wind tunnel test data	Complete validated data and photos should be available one week after the end of the test.	M0 + 1 week
3	Official wind tunnel test data	Official Tardis data and the test report should be available four weeks after the end of the test	M0 + 1 M

## 4. Topic value

The total value of biddings for this work package shall not exceed

**1,000,000 €**  
**[One million Euro]**

Please note that VAT is not applicable in the frame of the CleanSky program.

## Topic Description

CfP Topic Number	Title	Start Date	End Date
JTI-CS-2013-02-SFWA-03-014	Vibration reduction systems in pylon area	01-2014	
			04-2015

### 1. Topic Description

#### Background

The future installation of Counter Rotating Open Rotor (CROR) engines on aircraft is likely to induce higher vibration levels transmitted through the pylon structure. The main reasons are:

- higher engine vibrations
- shorter transmission path from engine to aircraft fuselage.

This foreseen risk can be mitigated by a thorough investigation of vibration reduction systems, including passive, semi-active or active means, to be studied for application first close to the source, second on the transmission path (pylon structure) and third on the various interfaces (engine/pylon, pylon/fuselage).

For the moment, there are no existing “off-the-shelf” solutions in the area, due to the specific environmental conditions: high vibration levels at low frequency (therefore large displacements, high temperature,...)

#### Scope of work

CROR engines will be installed on a rear fuselage section, supported by isostatic mounts at the interface with a pylon structure.

#### Inputs:

- a) Envelope of the excitation levels of vibration coming from the engine:
  - The levels of acceleration expected are between 1 g and 5 g at low frequency
  - Frequency bandwidth of the study: [0-50] Hz.
  - 2 types of excitations are expected: a transient failure case and a frequency steady case.
- b) Finite element model, condensed or not, of the different parts: engine, mounts, pylon, aircraft interfaces.

#### Outputs:

Main outcomes of the activity inherent to the present CFP are dealing with:

- a design solution for vibration reduction system
- manufacturing and testing of the designed solution.

#### Description of work

The applicant shall perform the following activities:

- a) A trade-off study for the state of the art of vibrations reduction systems: passive, semi active or active,
- b) Evaluate the compatibility of these vibration reduction systems with available space and environmental conditions(e.g. temperature) on aircraft; adapt and select a technology,
- c) Evaluate and adapt the selected solution with respect to CROR vibration levels:
  - a. Close to the excitation source
  - b. On the transmission path (pylon structure)
  - c. On typical interface: engine/pylon and pylon/fuselage
- d) Manufacture a prototype of the selected solution,
- e) Perform a full characterisation of the prototype by tests: dynamic, static, ageing...

### 2. Special Skills, Certification or Equipment expected from the Applicant

The following skills are required:

- Large experience in designing and manufacturing of vibration reduction systems: passive and/or semi active and/or active
- Large experience in dynamic response analysis, finite element modelling
- Expertise in dynamic tests

**Clean Sky Joint Undertaking**  
**SP1-JTI-CS-2013-02-SFWA-03-014**

**3. Major Deliverables and Schedule**

<b>Del. Ref. Nr.</b>	<b>Title</b>	<b>Description (if applicable)</b>	<b>Due</b>
1	Trade-off study (report)	Trade-off study for the state of the art of vibrations reduction systems and evaluation of the compatibility with the aircraft requirements	T0 + 3 M
2	Evaluate and adapt the selected technology (report)	Analysis of the vibration reducing system in different location	T0 + 10 M
3	Manufacturing of prototype	Demonstrator	T0 + 13 M
4	Test results (report)	Test results and correlation with predictions	T0 + 15 M
5	Final Report (report)	Containing the result of deliverables 1 to 4 including conclusions and recommendations	T0 + 16 M

**4. Topic value**

The total value of biddings for this work package shall not exceed

**700.000 €**  
**[Seven hundred thousand Euro]**

Please note that VAT is not applicable in the frame of the CleanSky program.

**Clean Sky Joint Undertaking**  
**Call SP1-JTI-CS-2013-02**  
**Systems for Green Operations**

**Clean Sky – Systems for Green Operations**

Identification	ITD - AREA - TOPIC	topics	VALUE (€)	MAX FUND (€)
<b>JTI-CS-SGO</b>	<b>Clean Sky - Systems for Green Operations</b>	<b>19</b>	<b>11.520.000</b>	<b>8.640.000</b>
<i>JTI-CS-SGO-01</i>	<i>Area-01 - Definition of Aircraft Solutions and exploitation strategies</i>			
<i>JTI-CS-SGO-02</i>	<i>Area-02 - Management of Aircraft Energy</i>		<b>7.940.000</b>	
JTI-CS-2013-02-SGO-02-052	Electrical Starter / Generator disconnect system		700.000	
JTI-CS-2013-02-SGO-02-061	Technology development and fabrication of integrated solid-state power switches		540.000	
JTI-CS-2013-02-SGO-02-064	Cooperative System Design Simulation Environment for Energy System Applications		250.000	
JTI-CS-2013-02-SGO-02-066	HVDC fuses design, development, validation and integration		400.000	
JTI-CS-2013-02-SGO-02-069	High power SiC diodes for Starter-Generator rotating rectifier bridge applications		600.000	
JTI-CS-2013-02-SGO-02-073	Numerical and experimental cross analysis methodology for mechanical impacts on a composite structure		500.000	
JTI-CS-2013-02-SGO-02-074	Thermoelectric cooling solutions in harsh environment design and prototyping		350.000	
JTI-CS-2013-02-SGO-02-075	Power connectors development for Vapour Cycle System and non-pressurized area		300.000	
JTI-CS-2013-02-SGO-02-076	Study, sizing, development, prototyping of high power density, preferably self-air cooled e-motor and corresponding inverter		1.500.000	
JTI-CS-2013-02-SGO-02-077	Power cable modeling for WIPS electromechanical chain.		300.000	
JTI-CS-2013-02-SGO-02-078	Ice Phobic Coating Associated to Low Power Electromechanical Deicers		300.000	
JTI-CS-2013-02-SGO-02-079	Optical Fibre based self-monitoring Motor Drives		800.000	
JTI-CS-2013-02-SGO-02-080	ECS humidity optimisation		300.000	
JTI-CS-2013-02-SGO-02-081	Implementation carbon fibers for rotor of high speed rotating electric machine		500.000	
JTI-CS-2013-02-SGO-02-082	Lithium-ion energy storage module for Integrated 28Vdc Modular Power system		600.000	
<i>JTI-CS-SGO-03</i>	<i>Area-03 - Management of Trajectory and Mission</i>		<b>1.780.000</b>	
JTI-CS-2013-02-SGO-03-024	On-Board Information Correlation for a pilot's complete situational awareness in optimum trajectory decisional process		650.000	
JTI-CS-2013-02-SGO-03-025	Automatic flight plan management tool for integration in bench for avionics equipment validation		500.000	
JTI-CS-2013-02-SGO-03-026	Antenna system design and testing for an avionic weather polarimetric X-band radar		630.000	
<i>JTI-CS-SGO-04</i>	<i>Area-04 - Aircraft Demonstrators</i>		<b>1.800.000</b>	
JTI-CS-2013-02-SGO-04-009	Airline trials of green flight management functions		1.800.000	

## Topic description

CfP Nbr	Title	End date	T0 + 30 Months
JTI-CS-2013-2-SGO-02-052	Electrical Starter / Generator disconnect system	Start date	T0: Q1 2014

### 1. Background and context

New generation aircraft need high level of electrical power.

To answer this requirement, the electric generators increased in volume and thus their weight increased

To solve weight and volume this new high power electrical machines are designed be able to work in two modes:

Mode 1: starter to start the aircraft engine

Mode 2: generator to give electrical energy to the aircraft.

By this way, the current electrical generator of limited power and the pneumatic starter can be replaced by only one high power electrical starter-generator.

For safety reason, to protect the machines and engine gearbox, the starter-generator need to include a disconnect system.

Under the effect of an electrical pulse, this system has to allow to separate mechanically the gearbox from the starter-generator. The transmission of the mechanical energy is then no more possible. In mode 1, the starter cannot drive any more the gearbox. In mode 2 the gearbox cannot drive any more the electrical generator.

The purpose of this (CfP) is:

1) to explore innovative topologies and technologies of disconnect systems adapted for aircraft electrical generator using these high power machines as a starter and choose the best topology.

2) to develop, build and test the chosen disconnect system capable of operating (approximate figures to be confirmed in full specification):

-up to  $-55^{\circ}\text{C}$  to  $200^{\circ}\text{C}$

-within the speed range 0 to 24000 rpm

- between -400 to and 400 Nm

- at a weight around 2 kg max

- with very high reliability

- with resetability capability (system resetable with starter generator still installed on aircraft, at least 6 times)

- with testability on aircraft

- including manufacturing robustness, service life ...& cost objective

In this approach of disconnect system, criteria of compactness, weight reduction and conformity with harsh aeronautic engine environment (i.e 10 g) will be also an important part of this study.

This CfP is a technological and industrial challenge which provides opportunity of competitiveness on this important improvement part of disconnect system dedicated for new high power starter-generator for more electrical aircraft for European partners of Cleansky..

### 2. Scope of work

This study of disconnect system shall include following technical parts and activities:

1) Specification review,

2) Trade studies of innovative disconnect system technologies,



## Clean Sky Joint Undertaking

### SP1-JTI-CS-2013-02-SGO-02-052

- 3) Definition of criteria for solutions analysis,
- 4) Comparative analysis and solution selection,
- 5) Description of final hardware design solution proposed. Verification and justification of compatibility of chosen solution with aeronautic environment,
- 6) Methodology and definition of verification tests,
- 7) Design and Manufacturing of the solution,
- 8) Carrying out the tests,
- 9) Analysis of results and conclusion regarding installation in a starter-generator.

The tests will be done on 5 (tbc) disconnect equipment.

Test conditions shall include parameters such as temperature, stress, fatigue, and aging.

Tools will be required to do the tests in the required conditions (ex: real part under stress).

### 3. Type of work

The activities of this work shall be limited to 30 months time period. A kick-off meeting, a progress meeting and final meeting will be scheduled with topic manager. This project is split into following tasks proposed for the applicant activities:

**At T0 (assumed October 2012 (To Be Confirmed)):**

Kick of meeting to start project. Review of technical specification and planning to be frozen.

**Task 1: (T0+2M):** Clause by clause and final specification version.

**Task 2: (T0+5M):** Report of trade study of innovative solutions explored with different technologies (concepts, schematics, working drawings)

**Task 3: (T0+6M):** Criteria definition for trade study analysis.

**Task 4: (T0+9M):** Preliminary design review of trade studies in accordance with specification. On the basis of the chosen criteria comparison of the different solutions. Solution selection.

**Task 5: (T0+15M):** Critical design review of technical proposal for disconnect system. Review of the justification report of hardware solution dimensioning, demonstrating the compatibility with mechanical, electrical, thermal and fluidic environment of the starter-generator and the aeronautical environments.

**Task 6: (T0+22M):** Review of verification and validation tests procedure

**Task 7: (T0+24M):** Delivery of five (relevant value to be defined) hardware samples for verification and validation

**Task 8: (T0+29M):** Review of tests report (analysis of the test results, report and conclusions)

**Task 9: (T0+30M):** Review of final report synthesis and conclusion

Progress reports will be requested every two months.

Detailed definition of the test plan, with the aim of covering extensive combinations of electrical, mechanical (vibration, shocks,...), temperature, test parameters, definition of the acceptance criteria, will be a joint activity with THALES..

### 4. Special skills, certification or equipment expected from the applicant

For this study, the applicant shall satisfy following minimum criteria:

- Company with a very opened and innovative spirit,
- Good background and experience in electro-mechanical design and advanced technologies operating in harsh aeronautic environment,
- Insurance shall be provided to manage this work in time without delay for study and development phases.
- Adequate equipment with tools, for thermal, electrical and mechanical simulations, manufacturing process and test benches to develop and test requested demonstrators in respect with milestone of delivery,
- Available resources to execute the respective tasks should be stated in the proposal.
- Laboratory for material tests (if not sub-contacted), in various environment conditions.
- Expertise on metallic, composite and plastic materials used at high temperature level
- Experience in aeronautics material tests, and qualification methodology.

## Clean Sky Joint Undertaking SP1-JTI-CS-2013-02-SGO-02-052

### 5. Major deliverables and schedule

Deliverable	Title	Description (if applicable)	Due date
D1	Requirements Analysis	Review and finalisation of module requirements specification (clause by clause) and SOW (statement of work)	T0+2M
D2	Report of trade study of potentials topologies suitable with the specification	Concepts of innovative solutions defined by schematics, working drawing, description Minimum of three potential solutions shall be proposed.	T0+5M
D3	Report of criteria definition	List of criteria to be used for solution choice	T0 + 6M
D4	Preliminary Design Review (PDR) of trade studies according the specification of the need and of the starter-generator environment	Analysis of benefits and drawbacks of potential solutions Technical description of concept , structure, functionality and technologies of proposed solutions. Selection of solution.	PDR: T0+9M
D5	Critical Design Review of frozen solutions of disconnect system selected for hardware design and analysis	Design file, bill of material and technical documents necessary to justify solution dimensioning, demonstrating the compatibility with mechanical, electrical, thermal and fluidic environment of the starter-generator and the aeronautical environments.	CDR T0+15M
D6	Delivery of tests plan and tests procedures	This document will define the list of tests to be applied, the tests sequence, the procedure to make these tests and the number of equipments to be summated to the tests.	T0+22M
D7	Delivery of 5 hardware prototypes of disconnect system	These prototypes will be tested for verification and validation on mechanical, temperature, electrical, aeronautic environment	T0+24M
D8	Reports of tests performed with selected solutions	Tests reports	T0+29M
D9	Final report	Synthesis and conclusion of study	T0 + 30M

### 6. Topic value (€)

The **maximum value** for this topic is:

**700,000 €**

**[Seven hundred thousand Euro]**

Please note any proposal above this value will NOT be eligible.

## Topic description

CfP Nbr	Title	End date	TO + 16 Months
JTI-CS-2013-2-SGO-02-061	Technology development and fabrication of integrated solid-state power switches	Start date	TO: Q1 2014

### 1. Background

This activity will support the design, fabrication and evaluation of a highly integrated matrix converter. The converter will be based on fully bond-wire-less double-sided cooled *sandwich* power module technology. The activity aims to demonstrate TRL6 technology maturity and deliver a fully functional power converter. Sandwich packages have no bond wires, can be cooled from both sides delivering improved thermal performance and can be optimised to give exceptionally low parasitic inductance. At system level, unprecedented power densities, efficiency and reliability can be achieved. However, the assembly of such structures can be quite complex and its technology readiness level is dependent on a number of choices for the specifically selected packaging and cooling features.

The key target of this work is therefore to ensure the achievement of TRL6 technology maturity, by developing, delivering and testing optimum interconnect and cooling solutions. The Topic Manager is seeking a partner who can contribute to the targets detailed below.

### 2. Scope of work

#### 1) Design study:

Prepare a fully justified electro-thermal and thermo-mechanical design for the planar module assembly process, addressing both Silicon (Si) and Silicon Carbide (SiC) technology and according to design guidelines provided by the Topic Manager.

#### 2) Planar module fabrication and assembly:

Establish reliable technologies to realise contact features and interconnect posts on DBC (Direct Bonded Copper) or AMB (Active Metal Brazed) substrates and on the top metallisation of power devices.

The target minimum feature size is < 0.3 mm x 0.3 mm with a height of at least 0.5 mm. Materials, coplanarity and compliance to suit the chosen assembly process based on design study 1) and in service requirements. The applicant should have access to and be in a position to procure latest technology devices, both in Si and SiC and substrates; ideally, the applicant should be autonomous in finishing/preparing the devices for use in a sandwich type package including a comparative analysis of soldered and sintered top-surface.

#### 3) Cooling:

State-of-the-art cooling solutions will be investigated, including both passive and active options. In particular, special attention will be devoted to the development of jet-impingement direct substrate liquid cooled solutions. Heat-sinks will be manufactured and delivered together with the power switches to be assembled into a power system. The heat-sink will allocate a suitable number of basic switches to maximise modularity and ease of system assembly.

#### 4) Power switch manufacturing route:

Establish a manufacturing and assembly process for the power switch suitable for TRL6 demonstration and higher.

#### 5) Feasibility study on integration within the power switch of monolithically integrated gate driver chip(s).

Next to the advanced development of power interconnects, this activity will consider, in the form of a feasibility study, embedment of monolithically integrated gate driver chips. Information about the chips can be procured by external sources. Both Si and SiC gate-driver chips will be considered.

More details can be made available upon request by the applicant.

**3. Type of work**

1) Design study:

A mixture of electro-thermal and thermo-mechanical simulation will be required to establish optimum design choices for the proposed substrate and module assembly. The study will encompass both Silicon (Si) and Silicon Carbide (SiC) based electronics.

2) Technologies for sandwich packaging fabrication at TRL6 level:

Investigate manufacturing and assembly processes including solder and solder-less solutions. Study optimum interconnect materials, geometries and sizes for a specific case-study and define optimum solutions for both Si and SiC power switches. Interconnect can include a mixture of soldered and non-soldered solid posts and will include both electrical/mechanical interconnects and thermal/mechanical interconnects.

3) Cooling:

A part of this activity will specifically target the design and fabrication of optimum cooling solutions, including jet impingement direct-substrate cooling.

4) The feasibility study in the integration within the power switch of monolithically integrated gate driver chips will have the form of a report detailing a viable design of such a switch. The report will detail both interconnecting solutions and switch layout for optimum switching performance.

**4. Special skills, certification or equipment expected from the applicant**

The successful partner will have demonstrated expertise and manufacturing capability of solid-state power switches for the avionic/aerospace industry. They will be independent in manufacturing and/or sourcing the required assembly parts, including interconnects and heat-sink; the partner will have access to latest technology semiconductor power devices and substrates. Experience in the application of electrical, thermal and mechanical co-design is essential as is the knowledge and capability of carrying out technology qualification tests in conformity with standard avionic specifications to ensure the achievement of TRL6 level.

The partner will have experience and be certified for the industrial development of power switches for avionic/aerospace applications and be confident with innovative interconnect, packaging and cooling solutions. The partner will include at least a power switch manufacturer of proven experience in the avionic domain, equipped and resourced to provide the type and number of modules required for programme evaluation. Finally, the partner will be able to demonstrate an established track record in working with industry and academia on power module technologies for aerospace applications.

**5. Major deliverables and schedule**

Deliverable	Title	Description (if applicable)	Due date
D1	Detailed substrate and process design	Fully justified design including mechanical, thermal and life models	T0 + 3 Months
D2	Power switches	Samples of power switches to pre-agreed specification with Topic Manager available	T0 + 6 Months
D3	Cooling solution	Samples of heat-sinks/liquid cooler to match D2 available	T0 + 9 Months
D4	Prototypes at TRL4 specification	Integrated power converter cell available for functional testing	T0 + 10 Months
D5	Prototypes at TRL6 specification	Integrated power converter cell available	T0 + 14 Months
D6	Feasibility study on integration of monolithic gate driver chip(s)	Report with viable design details available	T0 + 16 Months

**Clean Sky Joint Undertaking**  
**SP1-JTI-CS-2013-02-SGO-02-061**

**6. Topic value (€)**

The maximum value for this topic is:

**540, 000 €**

**[Five hundred and forty thousand Euro]**

Please note any proposal above this value will NOT be eligible.

## Topic description

CfP Nbr	Title	End date	T0 + 24 months
JTI-CS-2013-2-SGO-02-064	Cooperative System Design Simulation Environment for Energy System Applications	Start date	T0: Q1 2014

### 1. Background

The Systems for Green Operations ITD of Clean Sky aims to demonstrate substantial environmental and economic benefits of more electric aircraft systems technologies. The design and validation of such highly integrated systems urge the need for more co-operative development processes involving aircraft, engine, and equipment manufacturers. The design process has to be supported through advanced modelling and simulation capabilities. Therefore the goal of the consortium is to define standardised modelling methods and tools in each phase of the energy system design process. This is examined for instance in the Use Case: “*Development of a modular energy system simulation tool-chain*” as part of SGO WP2. In this example, collaborators from the aircraft industry use the FMI Standard [1] in order to integrate their models in a total system simulation. Whereas this work has largely been conducted successfully, it also revealed still on-going demand for more light-weighted and freely accessible simulation tools for collaborative modelling processes. In particular,

- (a) the dependence on one specific tool vendor in the design process shall be greatly reduced,
- (b) unit and regression testing shall be applied over different tools in order that models can be safely utilized in different tools,
- (c) connecting models from different suppliers and simulation tools for a unified system simulation shall be possible in a freely accessible tool.

The basis to reach these goals within this CfP is PySimulator [3], a Python based, open source environment for simulating FMU's [1], and running other simulation engines such as Dymola, SimulationX or OpenModelica. The central idea of PySimulator is to provide a generic framework to perform simulations with different simulation engines in a convenient way, to organize the persistent storage of small and huge result data sets, to provide plotting and other post-processing feature such as signal processing or linear system analysis, and to export simulation and analysis results to other environments such as Matlab. The major innovation of PySimulator is its plugin system: Nearly all operations are defined as plugins with defined interfaces. Several useful plugins are already provided, but anyone can extend this environment by his/her own plugins and there is no formal difference to plugins already provided. Thus, this open source tool can be used by each partner independently of any commercial simulation environment used for FMU generation.

### 2. Scope of work

*In this CfP several open source plugins shall be developed for PySimulator along the goals from above. In particular:*

#### **A. UNIT and REGRESSION TESTING:**

- (1) *Simulator plugin for one additional commercial simulation engine for Modelica models (such as MapleSim or Wolfram SystemModeler; but not Dymola or SimulationX, since these tools are already supported in PySimulator). There is an existing plugin interface for Simulator plugins in PySimulator. According to this interface the selected simulation engine has to be interfaced.*
- (2) *Extend an existing plugin to perform unit- and regression testing over two and more models in PySimulator (especially different versions of the same model, FMUs generated from the same model by different tools, simulating a Modelica model with different simulation engines). The test definition shall be defined with a GUI and textually by scripting. Output of a typical test is a report including a measure of the difference of the simulation results, detailed information about the differences and result plots.*
- (3) *Parallelization of the simulation and analysis runs for unit- and regression testing on a multi-core machine.*

## Clean Sky Joint Undertaking SP1-JTI-CS-2013-02-SGO-02-064

### B. SIMULATION of CONNECTED FMUs:

- (4) Connecting FMUs (FMI standard version 2.0, [3]) textually and using at least a connection GUI. Handling of many input/output signals that need to be connected shall be possible. An automatic check has to inform if connections are not in line with FMI standard. The connection schema has to be saved for reloading it in a following session.
- (5) Simulate connected FMUs from (4) both for Model Exchange and Co-Simulation including handling of algebraic loops for Model Exchange. This means especially to implement a Simulator plugin for the Co-Simulation Master algorithm that controls the FMUs for Co-Simulation. The already available Simulator plugin for FMUs for Model Exchange in PySimulator shall be used as basis for a Simulator plugin for connected FMUs for Model Exchange.

### 3. Type of work

The partner needs to have access to a commercial Modelica model simulator for (1). Further, handling of Functional Mock-Up Units (FMUs) is a key part of the work. The main code has to be implemented in Python and some parts possibly in C. The code has to include a documentation of it.

#### License

The complete software and documentation to be delivered have to be open source with a license not more restrictive than LGPL. Especially, the GPL license is not acceptable.

### 4. Special skills, certification or equipment expected from the applicant

The partner has to have knowledge and proven experience in most of the following topics:

- Modelica,
- FMI standard,
- Python, also GUI programming,
- C,
- Dynamic system simulation,
- Parallelization of simulation runs,
- Co-Simulation,
- Algorithms from graph theory to evaluate connected blocks,
- Software to solve differential algebraic equations.

### 5. Major deliverables and schedule

Deliverable	Title	Description (if applicable)	Due date
D1	New Simulator plugin	New simulator plugin of a commercial Modelica model simulator (software)	T0 + 6 months
D2	First prototype of a plugin for unit and regression testing	Plugin for unit and regression testing (software)	T0 + 6 months
D53	Second prototype of a plugin for unit and regression testing	Plugin for unit and regression testing with parallelized simulation and analysis runs (software)	T0 + 12 months
D4	First prototype of a plugin to simulate connected FMUs for Co-simulation	Prototype of a Simulator plugin for connected FMUs for Co-Simulation (software)	T0 + 15 months
D5	Second prototype of a plugin to simulate connected FMUs for Model Exchange and for Co-Simulation	Simulator plugin for connected FMUs for Model Exchange and Co-Simulation (software)	T0 + 20 months
D6	Final report and software	Report documenting the implemented features and constraints (document); and the final version of all plugins (software)	T0 + 24 months

**Clean Sky Joint Undertaking**  
**SP1-JTI-CS-2013-02-SGO-02-064**

**6. Topic value (€)**

The maximum value for this topic is:

**250,000 €**

**[Two hundred fifty thousand Euro]**

Please note any proposal above this value will NOT be eligible.



## Topic description

CfP Nbr	Title	End date	TO + 24 months
JTI-CS-2013-2-SGO-02-066	HVDC fuses design, development, validation and integration	<b>Start date</b>	T0: Q1 2014

### Special clause

*The text of this topic contains the basic information for the applicant to understand the scope of work. However, more detailed data are available in a separate document that can be provided on request to the interested applicant.*

*Due to the confidentiality content of this supplementary information, it is necessary to enter a Non-Disclosure Agreement (NDA) with the Topic Manager.*

*Therefore the applicant (or group of applicants) who is willing to receive this detailed confidential info package, is invited to write to the call mailbox confirming the request.*

*The applicant (or group of applicants), after check by the Topic Manager, will receive an NDA to be signed in two originals and sent to the JU.*

*The JU will pass the NDA, signed by the applicant (or group of applicants) to the Topic Manager; the original of the NDA countersigned by the TM will be kept by the JU until the end of the publication period. Confirmation of signed NDA will be given to the applicant, together with the supplementary document.*

*Questions concerning the confidential data delivered will be handled in a separate Q/A document.*

### 1. Background

Aeronautics power distribution systems are usually protected by active switching components, driven by electronics. In order to reduce response time and simplify protection driving, fuses are being considered for Cleansky HVDC network (540VDC). This study may lead to future aircraft projects.

### 2. Scope of work

The objective of this task is to develop, test, and deliver fuses adapted to high DC voltage networks to be integrated into aircraft EPDS (Electrical Power Distribution System).

### 3. Type of work

**Tasks foreseen:**

1. Definition:
  - 1.1 State of the art of existing aeronautics fuses
2. Development:
  - 2.1 Module definition & realisation
3. Validation:
  - 3.1 Standalone module validation & testing
  - 3.2 TRL demonstration
4. Integration:
  - 4.1 Support integration & test into EPDS

*The fuses shall be compliant with the following requirements:*

  - 1- The fuse shall handle a 540VDC nominal voltage, with 5 seconds peaks of 750VDC and unlimited overvoltage of 650VDC.
  - 2- The fuse shall handle a 83A nominal current (at 51000ft) and be operational within the range [50A-200A].
  - 3- The fuse shall handle lightning currents of 700A during 300µs.
  - 4- The fuse melting time shall be lower than 3s at 300%\*In, 10ms at 1000%\*In (after fault condition declaration).

## Clean Sky Joint Undertaking SP1-JTI-CS-2013-02-SGO-02-066

- 5- The fuse lifecycle shall be long enough to minimize maintenance operations..
- 6- The fuse maximum weight is 200g.
- 7- The fuse shall be as compact as possible.
- 8- The fuse shall fit to the aeronautic environment constraints, as detailed in DO160 standard (altitude, pressure, temperature, accelerations, vibrations, humidity,...)
- 9- The fuse shall pass the fire and explosion safety tests described within UL508C standard.

#### 4. Special skills, certification or equipment expected from the applicant

- Aerospace or industry fuses supplier familiar with:
- HVDC
  - DO160 standard
  - UL508C standard
  - aerospace electrical network environment

#### 5. Major deliverables and schedule

Deliverable / Milestone	Title	Description (if applicable)	Due date
<b>D1</b>	Existing aeronautics fuses state of the art		T0+4 months
<b>M1</b>	PDR		T0+6 months
<b>M2</b>	CDR		T0+11 months
<b>D2</b>	Prototypes delivery		T0+12 months
<b>M3</b>	Prototypes testing		T0+12 months
<b>D3</b>	Test results analysis		T0+13 months
<b>M4</b>	Conception correction and improvements identifications		T0+14 months
<b>D4</b>	Updated prototypes delivery		T0+19 months
<b>M5</b>	Updated prototypes testing		T0+19 months
<b>D5</b>	Test results analysis		T0+20 months
<b>M6</b>	Industrialisation		T0+21 months
<b>D6</b>	Final report		T0+22 months
<b>M7</b>	Technical support to integration & test of the fuses into EPDS		T0+23 months

#### 6. Topic value (€)

The **maximum value** for this topic is:

**400, 000 €.**

**[Four hundred thousand Euro]**

Please note any proposal above this value will NOT be eligible.

## Topic description

CfP Nbr	Title	End date	T0 + 18 Months
JTI-CS-2013-2-SGO-02-069	High power SiC diodes for Starter-Generator rotating rectifier bridge applications	Start date	T0 : Q1 2014

### 1. Background

Future Aircraft need more electrical power on board. The associated electrical generator weight increase can be a drawback for MEA architectures. So generator manufacturers are looking for solutions to reduce the mass of these machines. Two of them are to increase their speed and power density. In this aim, new rotating diodes devices can be envisaged on the rotor of the machine. They combine three improved characteristics such as high junction temperature capabilities, low rectifying losses and high strains capabilities.

The existing PN Silicon dies have a maximum junction temperature of 180°C and their maximum stress capability prevents the rotor to be used over 24000RPM. The goal of this topic is to develop a die able to stand 50% higher stress, a current density improved by 20%, rectifying losses reduced by 30% regarding standard PN silicon die. This new substrate will have to be able to stand 230°C junction temperature.

### 2. Scope of work

1. To define the new die substrate,
2. To design new die,
3. To manufacture new die mock-up,
4. To characterize electric performances,
5. To evaluate mechanical and fatigue capabilities,
6. To evaluate robustness to an environmental representative stress.

### 3. Type of work

Task 1 (T0+2M): definition of the new die,

Task 2 (T0+6M): definition of the substrate material and die design able to satisfy specification provided by the company of the topic manager,

Task 3 (T0+12M): deliver die mock-up according to the definition,

Task 4 (T0+18M): Evaluate electric, mechanical and robustness performance according to evaluation procedures specification jointly by the applicant and the company of the topic manager.

### 4. Special skills, certification or equipment expected from the applicant

The applicant will be able to:

- design and product dies,
- characterize electrical tests,
- conduct fatigue and combined robustness tests.

### 5. Major deliverables and schedule

Deliverable	Title	Description (if applicable)	Due date
D1	Report on die definition		T0 + 1 Month
D2	Delivery of prototypes		T0 + 12 Months
D3	Report on performances		T0 + 15 Months
D4	Report on robustness		T0 + 17 Months

**Clean Sky Joint Undertaking**  
**SP1-JTI-CS-2013-02-SGO-02-069**

**6. Topic value (€)**

The **maximum value** for this topic is:

**600,000 €**

**[Six hundred thousand Euro]**

*Please note any proposal above this value will be NOT be eligible.*

## Topic description

CfP Nbr	Title		
JTI-CS-2013-2-SGO-02-073	Numerical and experimental cross analysis methodology for mechanical impacts on a composite structure	<b>End date</b>	T0 + 24 Months
		<b>Start date</b>	T0: Q1 2014

### Special Clause

*The text of this topic contains the basic information for the applicant to understand the scope of work. However, more detailed data are available in a separate document that can be provided on request to the interested applicant.*

*Due to the confidentiality content of this supplementary information, it is necessary to enter a Non-Disclosure Agreement (NDA) with the Topic Manager.*

*Therefore the applicant (or group of applicants) who is willing to receive this detailed confidential info package, is invited to write to the call mailbox confirming the request.*

*The applicant (or group of applicants), after check by the Topic Manager, will receive an NDA to be signed in two originals and sent to the JU.*

*The JU will pass the NDA, signed by the applicant (or group of applicants) to the Topic Manager; the original of the NDA countersigned by the TM will be kept by the JU until the end of the publication period. Confirmation of signed NDA will be given to the applicant, together with the supplementary document.*

*Questions concerning the confidential data delivered will be handled in a separate Q/A document.*

### 1. Background

Electrical ice protection systems rely on the integration of deicers within aircraft structure in order to get best thermal or mechanical efficiency, depending on their operating principle. Resulting assemblies, including deicers and structural layers, shall sustain all environmental conditions and especially FOD (Foreign Objects Damages) but also any mechanical impact from in-service operation (tools impact, external equipment such as ladders, etc...).

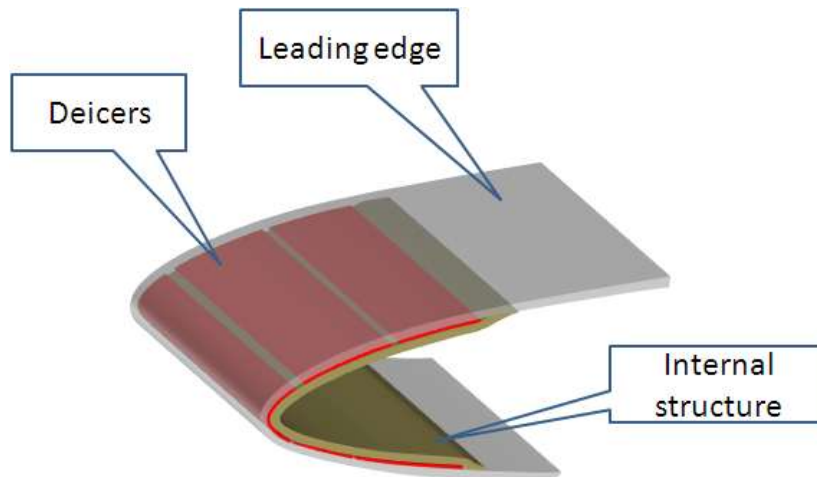

*Typical configuration of leading edge with integrated deicers*

While it is quite easy to ensure best mechanical protection of heaters (with reinforced layers) in leading edges, improvement toward lightweight solutions leads toward a threshold beyond which mechanical impacts may damage deicers while leaving main structure almost intact, hence maintenance indetermination.

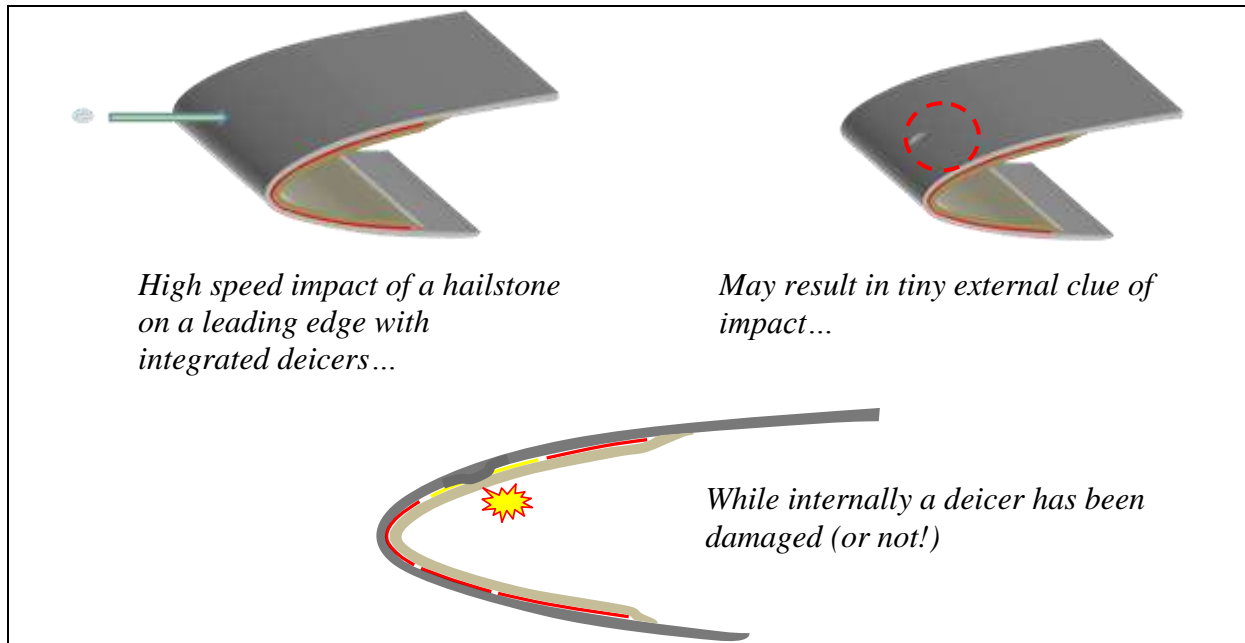

## 2. Scope of work

The purpose of this CFP is to build up a methodology based on an experimental test bench and numerical models to analyze mechanical behavior of a composite structure against impacts (Hailstones, various impacts ...).

Rather than the exhaustive use of heavy numerical modeling tools and existing software, it is proposed to follow a phenomenological approach, retrieving data from tests and assessing behavioral laws for later predictive approach and improvement of deicers integration.

A progressive approach is suggested, taking advantage of a cross analysis between experimental results and models. A test bench will be defined and built to perform simple tests on various configurations, in order to get a link between observed damages (external effects) and non visible ones (internal, on deicers).

## 3. Type of work

### **Phase 1: Requirements specification of numerical model**

- 1.1/ Bibliographic study: Norm and experiences relative to impact sizing
- 1.2/ Bibliographic study: Test means able to recreate impact characteristics with a capability of settings to allow variations of impacts used to develop and confirm numerical models
- 1.3/ Writing of both specifications: test bench (mechanical) and numerical tool

### **Phase 2 : Tools development**

- 2.1/ Pre study of the impact test bench and numerical model
- 2.2/ Design and manufacturing of test bench (manufacturing may be subcontracted)
- 2.3/ First issue of numerical model
- 2.4/ Development of a test method
- 2.5/ Development of a control to compare the samples before and after impact tests.

### **Phase 3: Preliminary validation of the tools**

- 3.1/ Validation of the test bench: conformity of the impact with the specification (energy level, impact geometry, etc...).
- 3.2/ First comparison of real impacts and model results with simple composite structures.
- 3.3/ Update of the numerical tool according to first tests campaign.

### **Phase 4: Total tests plan and completion of the numerical tool**

- 4.1/ test campaign with test bench on all the impact cases defined and on composite structure representative of existing integration method (deicers included)
- 4.2/ Calculation campaign on all the test cases
- 4.3/ Completion of the numerical tool

## Clean Sky Joint Undertaking SP1-JTI-CS-2013-02-SGO-02-073

### 4. Special skills, certification or equipment expected from the applicant

1/ Physical analysis of the impact phenomena  
 2/ Mechanical and automatism design capabilities (test bench)  
 3/ Control of composite structure (C scan use to be confirmed)  
 4/ Development and use of numerical tool (examples: LS Dyna or Ansys multi physics software).

### 5. Major deliverables and schedule

Deliverable	Title	Description (if applicable)	Due date
D1	Numerical tool first issue	According to existing knowledge concerning impact and numerical simulation and requirements specification on the tool, a first issue of the numerical tool is performed	T0+12months
D2	First issue of impact test bench	According to requirements of norms and development of numerical tool the test bench is designed and manufactured	T0+11months
D3	2 <sup>nd</sup> release of the numerical tool	A first campaign of impact test will allow us to validate the performances of the test bench. This campaign will also allow a comparison of numerical calculation and real results. According to this comparison the numerical tool is updated	T0+17months
D4	Final impact test bench	After validation of the test bench performances updating will be performed to have the final issue of the test bench	T0+20months
D5	Final numerical tool	An entire impact test campaign will be performed. To validate the bench and the numerical tool on all the range of impact characteristics. Numerical tool would be updated	T0+23months

### 6. Topic value (€)

The maximum value for this topic is:

**500, 000 €**  
**[Five hundred thousand Euro]**

Please note any proposal above this value will NOT be eligible.

## Topic description

CfP Nbr	Title	End date	T0 + 22 Months
JTI-CS-2013-2-SGO-02-074	Thermoelectric cooling solutions in harsh environment. Design and prototyping	Start date	T0: Q1 2014

### Special Clause

*The text of this topic contains the basic information for the applicant to understand the scope of work.*

*However, more detailed data are available in a separate document that can be provided on request to the interested applicant.*

*Due to the confidentiality content of this supplementary information, it is necessary to enter a Non-Disclosure Agreement (NDA) with the Topic Manager.*

*Therefore the applicant (or group of applicants) who is willing to receive this detailed confidential info package, is invited to write to the call mailbox confirming the request.*

*The applicant (or group of applicants), after check by the Topic Manager, will receive an NDA to be signed in two originals and sent to the JU.*

*The JU will pass the NDA, signed by the applicant (or group of applicants) to the Topic Manager; the original of the NDA countersigned by the TM will be kept by the JU until the end of the publication period. Confirmation of signed NDA will be given to the applicant, together with the supplementary document.*

*Questions concerning the confidential data delivered will be handled in a separate Q/A document.*

### 1. Background

“More electric” aircraft requires more power and low level electronics integration. Cooling is a key driver to reach weight, volume and reliability objectives. Moreover, harsher and harsher environment are now encountered and local cold source or heater are highly required.

Thanks to their passive cooling and/or heating capability Thermo Electric Cooling constitutes a potential solution. However, the demonstration of their functioning in avionic application, by modelling and experimental tests, is required before being equipped on an airplane.

### 2. Scope of work

The aim of this work is to develop a TEC for avionic application which maturity level is TRL5 with low power consumption and high efficiency. Object is to propose a cooling solution for high environment temperature electronic and also start up in very low temperature case. Typically one hundred of watts are dissipated over several localized area with heat flux density around 30 W/cm<sup>2</sup>, the equipment is located in a harsh environment characterized by an ambient temperature from -70°C to 160°C and a low heat exchange coefficient. Despite, its maximal temperature should be in the range -55°C / +125°C. Mechanical integration is one of the main key points of using such solutions in harsh constraints. The cooling of new high density generation of electronic for future application constitute a real challenge , and constitute a real technological breakthrough for more electrical aircraft.

### 3. Type of work

The scope of this work is:

- Bibliography review, in particular intense state of the art regarding integration constraints (mechanical and thermal constraints)
- Technology selection:
- Sizing / modelling: a full descriptive thermal model and thermo mechanical modelling have to be developed in order to fulfil thermal and reliability objectives.
- Prototype construction: a representative prototype has to be developed in order to be fully representative of aeronautical environment applications integration
- Experimental validation:

Thermal, mechanical test have to be performed. In particular, thermal and mechanical cycling



## Clean Sky Joint Undertaking

### SP1-JTI-CS-2013-02-SGO-02-074

(joined constraints).

#### 4. Special skills, certification or equipment expected from the applicant

The applicant should have knowledge in TEC and heat transfer. The capability of experimental validation (thermal performance, vibration response ...) is required (internal or external).

#### 5. Major deliverables and schedule

Deliverable	Title	Description (if applicable)	Due date
D1	Synthesis of bibliography and justification of technology and fluid selection		T0 + 4 Months
D2	Modelling results: justification of design		T0 + 10 Months
D3	Prototype definition		T0 + 16 Months
D4	Experimental characterization		T0 + 22 Months

#### 6. Topic value (€)

The **maximum value** for this topic is

**350, 000 €.**

**[Three hundred fifty thousand Euro]**

Please note any proposal above this value will NOT be eligible.

## Topic description

CfP Nbr	Title	End date	T0 + 15 months
JTI-CS-2013-2-SGO-02-075	Power connectors development for Vapour Cycle System and non-pressurized area	Start date	T0: Q1 2014

### 1. Background

In the frame of Clean Sky SGO ITD, the member is developing a thermal load management system based on vapour cycle system. Due to increasing part of heat load to cool down in more electrical aircraft, the cooling power of the VCS needs to be optimized accordingly.

Actually, the member investigates new solutions with a cooling power greater than 20 KW to take into account heat load requirements and adapted to 540 HVDC electrical networks. In this configuration, specific hermetic power connectors adapted to vapour cycle system requirements and HVDC network with a switching frequency between 10 and 20 kHz need to be developed.

### 2. Scope of work

This call for proposal aims to select a partner in charge of the design and the development of hermetic power connectors suitable for Vapour Cycle System and non-pressurized area. A comparative study between different configurations (crimp connectors, etc.) may be carried to select the most appropriate solution according to specified Wiring Gauge, switching frequency (between 10 and 20 kHz) and fundamental frequency (between 1 and 2 kHz). Such connector technology should:

- ‘ ensure a sealing with an overall leakage rate lower than 10<sup>-8</sup> mb.L/sec under 2 bars gauge of He.
- ‘ be adapted to VCS application environment and shall operate properly with an internal refrigerant temperature ranging from – 55°C to 150°C.

### 3. Type of work

This study will include design and experiment test in a demonstrator provided by the member.

### 4. Special skills, certification or equipment expected from the applicant

SME having significant experience in hermetic power connector development for aerospace applications.

### 5. Major deliverables and schedule

Deliverable	Title	Description (if applicable)	Due date
D1	Agreed Detailed Specification		T0 + 1 Month
D2	Design concepts models and study leading to best solution		T0 + 3 Months
D3	CDR		T0 + 5 Months
D4	Delivery of prototype for validation	Internal tests (carried out by topic manager) will enable to validate the performance of the hermetic connector and its compatibility with the vapour cycle system developed within Clean-Sky SGO. Some ways of improvement may be identified after the tests	T0 + 9 Months
D5	Delivery of the optimized prototype	Optimized connectors based on tests (D4)	T0 + 15 Months

**Clean Sky Joint Undertaking**  
**SP1-JTI-CS-2013-02-SGO-02-075**

**6. Topic value**

The **maximum value** for this topic is:

**300, 000 €**

**[Three hundred thousand Euro]**

Please note any proposal above this value will NOT be eligible.

## Topic description

CfP Nbr	Title	End date	T0 + 22 Months
JTI-CS-2013-2-SGO-02-076	Study, sizing, development, prototyping of high power density, preferably self-air cooled e-motor and corresponding inverter	<b>Start date</b>	T0: Q1 2014

### **Special Clause**

*The text of this topic contains the basic information for the applicant to understand the scope of work. However, more detailed data are available in a separate document that can be provided on request to the interested applicant.*

*Due to the confidentiality content of this supplementary information, it is necessary to enter a Non-Disclosure Agreement (NDA) with the Topic Manager.*

*Therefore the applicant (or group of applicants) who is willing to receive this detailed confidential info package, is invited to write to the call mailbox confirming the request.*

*The applicant (or group of applicants), after check by the Topic Manager, will receive an NDA to be signed in two originals and sent to the JU.*

*The JU will pass the NDA, signed by the applicant (or group of applicants) to the Topic Manager; the original of the NDA countersigned by the TM will be kept by the JU until the end of the publication period. Confirmation of signed NDA will be given to the applicant, together with the supplementary document.*

*Questions concerning the confidential data delivered will be handled in a separate Q/A document.*

### **1. Background**

The “Systems for Green Operations – Management of Aircraft Energy” research consortium investigates new system technologies for more environmentally friendly aircraft. To achieve this target two solutions are currently investigated under the headline of the “More Electric Aircraft”:

- “Electrification” of aircraft systems; and
- Electric propulsion of main and tail rotor.

Envisioned benefits for the development of electrically powered alternatives for hitherto hydraulically, pneumatically or mechanically powered systems are:

- Margin decrease thanks to energy communalisation
- Standardisation of components
- Creation of new solutions/architecture opportunities not available before
- Easier diagnostic of defective parts and monitoring (fault detection and Health monitoring capability)
- Easier and reduced maintenance due to unified and simplified integration (only 1 vector, i.e. electrical power only rather than electrical, hydraulic and pneumatic power)
- Application of a technology broadly available in other industries (automotive, industrial etc...)

Benefits for the electric propulsion are:

- Specific consumption gain
- Total weight and volume gain
- Increase of flight safety
- Noise reduction
- Enhanced performances on flight domain

In this context, one challenge is the development of electric motors and corresponding inverters that fulfil the following criteria (priority as listed):

- High reliability and safety (e.g. no consequences –resistive torque and fire - on internal coil short-circuit due to permanent magnet rotor presence);

## Clean Sky Joint Undertaking SP1-JTI-CS-2013-02-SGO-02-076

- Complete loss of function shall not occur with a probability higher than TBD per flight hour. This may require a certain level of redundancy. More information is provided in the supplementary document (ref. special clause).
- Some performance degradation is acceptable provided a certain probability of occurrence is not exceeded. More information is provided in the supplementary document (ref. special clause).
- High power-to-weight/power-to-volume ratio
- Self-air-cooled (usual cooling system used on Aircraft for electrical components)
- Low Recurring Cost (only for serial development - not applicable for this research project)

The motor along with its inverter to be developed under this call, for research purpose, shall have the following main characteristics (TBC in supplementary document, ref. special clause):

- 2 100 rpm ≤ output shaft speed ≤ 4 600 rpm
- Maximum continuous power = 5kW (for more than 5 minutes) (Torque: 23 Nm at 2 100rpm)
- Maximum medium transient power = 120 kW (for 5 minutes) (Torque: 546 Nm at 2 100rpm)
- Acceleration from 2 100rpm to 4 600rpm in 1.5s (additional information in supplementary document, ref. special clause)
- Power supply: The power supplies commonly available on aircraft are 28VDC and 115VAC (3-phase, 400Hz). If the applicant(s) prefer to use HVDC power supply, the preferred voltage would be 540VDC (floating). More information is provided in the supplementary document (ref. special clause). It may be assumed that more than 1 bus bar is available.
- Total efficiency (inverter and motor) objective: 95%
- Weight objective: <40kg (inverter and motor)
- At least one solution with a self-air-cooled system (motor and inverter - max cooling air temperature is 70°C at inlet). If an alternative cooling system is proposed (e.g. liquid), an additional proposal based on air cooling shall also be presented.
- Geared system for torque reduction can be proposed
- Dimensions:
  - Motor and inverter (integrated motor and inverter solution is preferred) compatible with at least one of the two volumes:

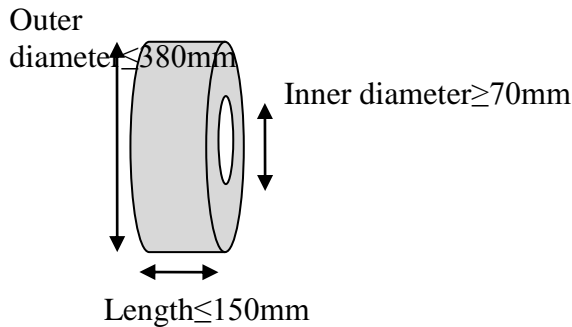

**Volume 1**

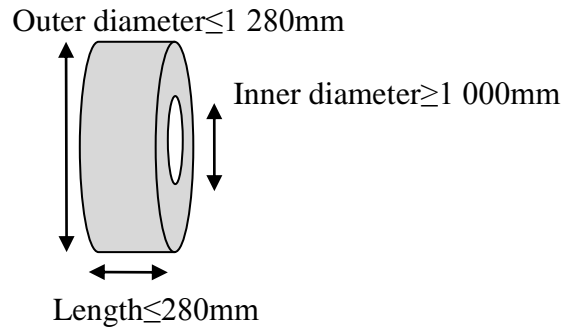

**Volume 2**

- Inverter (in case of non-integrated solution) compatible with the volume below:

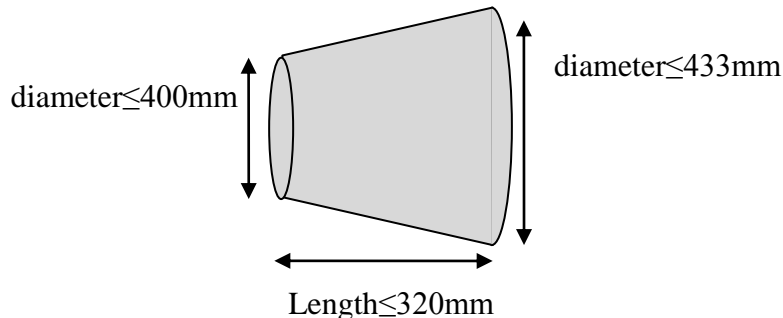

## 2. Scope of work

The work should be structured by work packages as follows:

**WP1** – Technology and concept study including among other things specification review (compliance matrix) and preliminary safety/reliability analysis

**WP2** – Motor and inverter pre-design including modelling (Electromagnetic, structural and thermal FEM)

**WP3** – Prototypes motor and inverter manufacturing

**WP4** – Characterisation/functional tests at supplier bench and functional/integration tests on test bench furnished by Topic Manager

**WP5** – Conclusion, TRL assessment and extrapolation for serial application including technical analysis, development/manufacturing plan and NRC/RC assessment

Another WBS may be proposed as long as the topics mentioned above are covered.

## 3. Type of work

In accordance with the technical specification provided at project start, the selected applicant(s) shall:

### **WP1:**

- Fill out the compliance matrix provided
- Write a preliminary technical description of motor and inverter complying with specification requirements and with at least one of the two volumes (see above): Several solution options may be proposed and evaluated against the specification. Down-selection to be performed in consultation with the Topic Manager.
  - Safety/reliability preliminary analysis
  - Functional synoptic (Motor and its sensors, electronic stage, EMC filters, insulation, power switches drivers, control loop, protection circuit, functional logics, safety functions, input/output etc..)
  - Technical component justification file: methods applied for component sizing (dynamic/static/transient) and applied margins (voltage, temperature...); substantiation (test results, FEM, simulation, analytical, experience...). Several design options on component level may be proposed and evaluated including at least one self-air-cooled motor design. Down-selection to be performed in consultation with the Topic Manager.
    - Electromagnetic and performance preliminary assessment
    - Thermal and environment preliminary assessment
    - Interface description
    - Weight breakdown and balance
    - Risk and/or Opportunity analysis
    - Export Control Classification and environment (e.g. RoHS) analysis
    - User's guidance
    - Electrical/mechanical Maintainability and electrical testability analysis
    - Patent analysis
- Organise a Preliminary Design Review (above deliverables update)

### **WP2:**

- Perform a pre-design of motor/inverter, control law and interfaces. This includes preparation of an Interface Control Document, of a CAD model (shall be in STEP format) and of a behavioural electrical model (SABER preferred).
- Develop component simulation model: Electromagnetic and thermal FEM + structural FEM if required. The tool to be used for thermal FEM shall be compatible with any CFD code. The results of the simulation shall be exportable to any other FEM tool.
- Organise a Critical Design Review (above deliverables update)

### **WP3:**

- Manufacture motor and inverter prototypes
- Organise Article Inspection

## Clean Sky Joint Undertaking SP1-JTI-CS-2013-02-SGO-02-076

- TRL3 assessment and validation

### WP4:

- Write proposal for Acceptance Test plan and agree it with Topic Manager
- Perform characterisation/functional test at supplier bench
- Write the Acceptance Test Report (supplier bench)
- Organise Article Inspection
- TRL4 assessment and validation
- Deliver prototypes along with test equipment set (monitoring PC, interfaces etc..) to Topic Manager
- Support functional/integration tests at facilities of the Topic Manager (central Europe)
- Update Acceptance Test Report after tests on Topic Manager's bench

### WP5:

- Update above deliverables
- Write project synthesis including:
  - Test bench assessments
  - Recommendation for higher TRL (up to serial production)
  - Development/manufacturing plan
  - NRC/RC assessment
- Fill out TRL final assessment form

#### 4. Special skills, certification or equipment expected from the applicant

Organizations or consortia bidding for this programme shall have industrially relevant experience in design and application of high power density, preferably self-air-cooled electric motors, inverters and related control tasks. Also a strong relevant background in simulation, rotating machine and inverter manufacturing shall be demonstrated.

The applicant(s) should provide all necessary resources (expertise, machines, tooling, materials, test means, etc.) required to perform the tasks described above. If not available, the development/sourcing of such resources, specifically machines, tooling and test means, shall be part of the proposal.

Ideally the applicant(s) can demonstrate skills/experience in "mechanical packaging" (bearings, housing, sensors, output shaft...) as well as mechanical and thermal integration (platform integration).

Aerospace experience and adequate EASA DOA (part-21) is recommended. If not, the supplier shall indicate its quality management plan/roadmap in the proposal.

#### 5. Major deliverables and schedule

Deliverable	Title	Description (if applicable)	Proposed due date
D1	Compliance Matrix		T0 +1 Month
D2	Preliminary technical description of motor and inverter concept(s)		T0 +3 Months
D3	PDR (D1, D2 updates)		T0 +7 Months
D4	ICD, 3D and behavioural/electrical model		T0 +7 Months
D5	EM and thermal FEM		T0 +7 Months
D6	CDR (D1, D2, D4, D5 updates)		T0 +10 Months
D7	Article Inspection		T0 +16 Months
D8	TRL3 validation		T0 +16 Months
D9	ATP		T0 +16 Months
D10	ATR – supplier bench		T0 +19 Months
D11	Article Inspection		T0 +19 Months
D12	TRL4 validation		T0 +19 Months

## Clean Sky Joint Undertaking SP1-JTI-CS-2013-02-SGO-02-076

D13	Prototype delivered to Topic Manager		T0 +20 Months
D14	ATR – on Topic Manager furnished test-rig		T0 +21 Months
D15	D1, D2, D4, D5 updates		T0 +22 Months
D16	Project synthesis		T0 +22 Months
D17	Final TRL assessment		T0 +22 Months

### 6. Topic value

The **maximum value** for this topic is:

**1,500, 000 €**

**[One million five hundred thousand Euro]**

Please note any proposal above this value will NOT be eligible.

### 7. Remarks

*The expected maximum length of the proposal Part B is 40 pages (Arial, font size 10).*

*Objective: TRL 4 or higher.*

*It is acknowledged that the overall schedule as expressed in chapter 5 is very tight. Intermediate due dates are provided as guidance. However the proposed schedule should be compliant with D13 and completion by December 2015.*



## Topic description

CfP Nbr	Title	End date	T0 + 18 months
JTI-CS-2013-2-SGO-02-077	Power cable modelling for WIPS electromechanical chain	Start date	T0: Q1 2014

### 1. Background

In the frame of Clean Sky SGO ITD, the topic manager aims to develop an electrothermal wing ice protection system for aircraft application.

The system is using heating mats able to operate in anti-icing and de-icing modes and directly linked to the power electronic unit with switching connectors adapted for 540 HVDC electrical networks. The centralized WIPS architecture can conduct a power cables length greater than 30 m. Therefore, the power cable technology is a key driver for the system optimization and needs to be optimised accordingly, in particular for weight reduction and to optimize voltage quality.

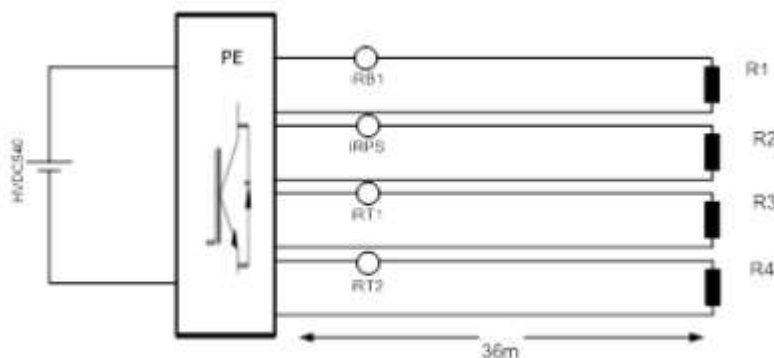

### 2. Scope of work

This call for proposal aims to select a partner in charge of the development of an optimized model of power cable behaviour. In particular, a representative modelling of power cable for HVDC WIPS application with the following characteristics:

- ‘ - high switching frequency (between 10 and 20 kHz)
- ‘ - fundamental frequency about 10 kHz is expected
- ‘ - R loads (heating mats) directly linked to DC network

This model will enable to improve the prediction of the overall electrical chain (power supply, cable, loads) and to optimize it in order to reduce losses and to avoid voltage spike, return current, etc.

### 3. Type of work

This study will include modelling study of power cable for aerospace applications. The applicant is expected to develop a model of the complete electromechanical chain of the Wing Ice Protection System in order to optimize the power cable functionality in high frequency impedance versus weigh and to make an assessment of the overall weight.

### 4. Special skills, certification or equipment expected from the applicant

University or SME having a significant experience in power cable design and modelling for aerospace applications

**Clean Sky Joint Undertaking**  
**SP1-JTI-CS-2013-02-SGO-02-077**

**5. Major deliverables and schedule**

<b>Deliverable</b>	<b>Title</b>	<b>Description (if applicable)</b>	<b>Due date</b>
D1	Agreed Detailed Specification		T0 + 1 Month
D2	Definition of methodology for power cable modelling		T0 + 8 Months
D3	Numerical tool first issue	A first issue of the numerical tool is performed	T0 + 11 Months
D4	Assessment report	Internal tests (carried out by topic manager) will allow a comparison of numerical calculation and real results. According to this comparison the numerical tool is updated	T0 + 13 Months
D5	Numerical tool update		T0 + 18 Months

**6. Topic value (€)**

The **maximum value** for this topic is:

**300, 000 €**

**[Three hundred thousand Euro]**

Please note any proposal above this value will NOT be eligible.

## Topic description

CfP Nbr	Title	End date	T0 + 14 months
JTI-CS-2013-2-SGO-02-078	Ice Phobic Coating Associated to Low Power Electromechanical Deicers	Start date	T0: Q1 2014

### 1. Background

The Hybrid Low Power Ice Protection system developed in the frame of Clean Sky JTI is using electro mechanical devices that shed ice which is accreted on the leading edge of the wing.

The wing leading edge structure comprises electromechanical actuators generating forces and inducing deformations on the metallic skin of the leading edge, also named "erosion shield".

The aim of the proposed work is to improve the electromechanical actuators efficiency by incorporating an ice-phobic coating on the erosion shield surface to decrease ice adhesion and thus help ice expulsion.

### 2. Scope of work

The aim of the contracted activity is to design an ice-phobic coating which will be incorporated on the erosion shield of the wing leading edge. The coating must have specific characteristics to minimize ice adhesion and be compliant with severe environmental conditions as encountered during aircraft flight.

The objectives can be divided in 5 steps as follows:

- 1- Investigate and propose coating material with ice phobic characteristics compliant with temperature range, droplet size and speed encountered in severe environmental conditions.
- 2- Evaluate, by using simulation, the variations of adhesions forces between ice and coating in temperature range for different droplet speed and size and for different angle of contact. Select the best solution.
- 3- Designing and manufacturing coating of appropriate material for validation.
- 4- Evaluation and testing selected coating by measuring ice adhesion forces in environmental condition as defined in task 2. Validate model used in task 2. Evaluate erosion resistance of the coating.
- 5- Manufacturing and delivering of coating to be applied on a large surface (600mm x 300mm).

### 3. Type of work

Establish with SGO Member detailed specification of the ice phobic coating: environmental and integration requirements.

Use model for adhesion forces evaluations.

Use material characteristics knowledge and expertise to design and manufacture efficient ice phobic coating for severe environmental conditions.

Use laboratory test facilities for measuring ice adhesion forces in several environmental conditions.

### 4. Special skills, certification or equipment expected from the applicant

Expertise in ice-phobic chemistry.

Expertise in surface structure.

Expertise and tool for simulation.

Ability to deliver and to characterize prototypes.

**Clean Sky Joint Undertaking**  
**SP1-JTI-CS-2013-02-SGO-02-078**

**5. Major deliverable and schedule**

<b>Deliverable</b>	<b>Title</b>	<b>Description (if applicable)</b>	<b>Due date</b>
D1	Agreed Detailed Specification		T0+1 month
D2	Concept review	Technical concepts review	T0+3 months
D3 (Task 2)	Design concepts models and study leading to best solution	Review of selected coating	T0+8 months
D4 (Task 3)	Delivery of coating prototype for validation		T0+10 months
D55 (Task 4)	Concept validation and optimization of selected coating	Concepts validation and optimization report	To+12 months
D6 (Task 5)	Delivery of coating of large surface (600mm x 300mm).		T0+14 months

**6. Topic value (€)**

The **maximum value** for this topic is:

**300, 000 €.**

**[Three hundred thousand Euro]**

Please note any proposal above this value will NOT be eligible.

## Topic description

CfP Nbr	Title	End date	TO + 24 Months
<i>JTI-CS-2013-2-SGO-02-079</i>	Optical Fibre based self-monitoring Motor Drives	<b>Start date</b>	TO: Q1 2014

### 1. Background

Electrical machines and drives being developed within the CleanSky programme are adopting novel, power-dense, circuit and electromagnetic topologies working close to the material limits and excited by non-conventional waveforms. This brings about requirements for increased health-monitoring and cooling demands for both motor and convertor and thus temperature and vibration monitoring are fundamental. This translates in an increase in temperature sensing requirements for correct thermal management and therefore added component count. With motor-drives going at high speeds and high frequency fundamental waveforms there are challenges for data acquisition and challenges for determining the rotor speed using resolvers. The use of such conventional sensors, for both temperature and position/speed measurements pose a significant reliability overhead.

Over the past years optical fibre sensors, based on Bragg gratings have been developed for quasi-distributed temperature and strain/vibration measurements. This fully optical system eliminates any Electromagnetic interference (EMI) issues for small signal applications such as those mentioned earlier. Following their correct placement within the structure to be analysed, the sensors themselves prove to be quite rugged and the airworthiness of interrogation equipment has also been demonstrated in the past.

This project therefore aims to explore the possibility of using such technology as a replacement to conventional bulky systems prone to EMI issues whilst at the same time provide a test platform which will provide the necessary feedback on the axial the circumferential distribution of key parameters such as temperature and strain. The same applies in terms of power electronic convertors for heat sink design validation and online device temperature monitoring (preventing thermal run-away and catastrophic failure of devices)

Thus the development of such a SMART self-monitoring motor drive provides a method for enhanced reliability and time-to-failure prediction.

The enhanced awareness of the internal state of the drive also allows scope for improved performance optimisation since the machine can be controlled to operate at its maximum limits which are continually monitored. Auto-tuning and adaptive parameter estimation algorithms will be researched for correct control of the supply waveforms in response to environmental conditions, faults and predicted machine lifetime against performance requirements.

The purpose of this CFP is to develop a test setup able to investigate the integration of In-fibre gratings within the electrical drive components including the machine itself and associated power electronics. Work will be done to extract temperature and strain data, this data will in turn be fed-back into lifetime models used to predict/monitor the drive's operating conditions. Potentially such data can also be used to influence the control strategy adopted. This CFP will help the European aeronautic partners to have better life consumption models, develop improved diagnostic techniques and improve reliability by reducing the amount of rotational sensors.

### 2. Scope of work

The aim of this CFP is to find a partner who has the necessary experience and capabilities to develop and investigate a high performance optical-fibre-based setup to achieve the twofold goals set out by such a call namely: to demonstrate the capability of integration of such a robust sensor system within the aerospace environment to monitor electrical machine and convertor parameters, and to develop a modular test bed capable of accepting similar fiber enabled drives to be tested. The latter will be used to validate design models by providing thermal and strain maps of the prototypical machines developed for the aerospace application.

In summary the flexible test setup delivered to the institution of the topic manager will be expected to fulfill the following requirements to ensure the testing of the aerospace drives:

## Clean Sky Joint Undertaking SP1-JTI-CS-2013-02-SGO-02-079

- Digitized measurement setup which can give reliable and repeatable results
- Flexible setup able to measure different physical parameters using the same sensing hardware
- Be capable of loading the electrical drive to the desired power-speed ratings (TBA)
- Capable of measuring vibration/speed/temperatures through conventional means for validation purposes.
- Be supplied with the relevant software for data acquisition and post-processing

The test setup will need to be able to provide for temperature/strain measurements for at least 1 duplex drive unit (2 motor units and 2 converter units), thus with a minimum of 16 interrogation channels. The motor drive performance requirements will be approximately 30kW @ 10krpm with an operating temperature range varying from -45 to 120 degC.

### 3. Type of work

The expected type of work will be mainly based around experimental development of the fibre network targeted towards enabling improved health monitoring and reliability. Associated interrogation electronics and algorithms will need to be developed and implemented. The integration of the sensory network into an actuator drive system will also be required.

### 4. Special skills, certification or equipment expected from the applicant

The chosen partner/consortium must exhibit demonstrable experience in the development of extrinsic optical fiber sensing solutions. It is essential that the applicant has a proven track record of research and development in novel application of such Fiber optic sensors.

### 5. Major deliverables and schedule

Deliverable	Title	Description (if applicable)	Due date
D1	Review report on the state-of-the-art in fiber optic, distributed sensing, solutions.	Review of fibre optic based sensors currently available and the preferred method of interrogation for both static and dynamic measured applications. Identification of required machine parameters ( <i>Measurands</i> )	T0+1
D2	Preliminary Design Review	Proposed methodology, including electrical drive (motor and convertor) selection used during initial system testing, sensor selection and interrogation methods to be used to measure the required machine parameters.	T0+4
D3	Critical Design review	Design review of test setup and detail of expected results.	T0+8
D4	Delivery, installation and commissioning of test setup	Using the chosen test drive ,a demonstration of capability of the setup to monitor the agreed upon <i>measurands</i> has to be presented as demonstration of the fibre-optic-based-self-monitoring-drive concept	T0+18
D5	Performance review	Report on the performance of the sensory network embedded within an aerospace drive. Performance indicators will be the ability to integrate these sensors reliably within such drives, the ability to detect failures, to measure temperature position and torque.	T0+23

### 6. Topic value (€)

The maximum value for this topic is

**800, 000 €.**

**[Eight hundred thousand Euro]**

Please note any proposal above this value will NOT be eligible.

## Topic description

CfP Nbr	Title	End date	T0 + 24 Months
JTI-CS-2013-2-SGO-02-080	ECS humidity optimisation	Start date	T0: Q1 2014

### 1. Background

Outside humidity treatment is a main contributor to ECS power requirement. To reduce this power it is needed to know exactly the not to exceed outlet humidity at the pack outlet.

Liquid water at Low Pressure ducting participates to cabin cooling but if this quantity is too high a fog can be seen.

### 2. Scope of work

The proposed work package can be separated into three sub-topics:

- 1) Determination by tests of a visibility fog criteria based on physical properties (air speed, liquid water content, blowing temperature, droplet size ....)
- 2) Development of a 0D tool to predict the size of the water droplets (liquid or ice) downstream a:
  - Heat exchanger
  - Pack outlet turbine
  - Mixmanifold
- 3) Validation of this tool based on tests of different packs and Heat Exchangers and Mixmanifolds

### 3. Type of work

The type of work is a function of each sub-topic:

- 1) Bibliographic search, brainstorming, and tests enabling to play independently of each parameter (speed, water content; droplet size ...)
- 2) Bibliographic search Detail design of the selected solution, prototype manufacturing and performance testing to validate flow capability and isentropic performances.
- 3) Tests by PIV or Optical device to determine water/ice droplets characteristics

### 4. Special skills, certification or equipment expected from the applicant

SME and/or laboratory having a significant experience on:

- 1) Diphasic modelling
- 2) Diphasic flow test facilities
- 3) Means to measure accurately the physical properties of the flow.

### 5. Major deliverables and schedule

Deliverable	Title	Description (if applicable)	Due date
D1.1	Bibliographic search report on fog visibility criteria	3 months	T0 + 3 Months
D1.2	Test report with definition of the fog visibility criteria	9 months	T0 + 12 Months
D2.1	Bibliographic search report on water droplet assessment downstream : -an HX -a turbine -a mixmanifold	3 months	T0 + 15 Months
D2.2	Delivery of the 0D tool which assess water droplet properties downstream :	3 months	T0 + 18 Months

**Clean Sky Joint Undertaking**  
**SP1-JTI-CS-2013-02-SGO-02-080**

	-an HX -a turbine -a mixmanifold		
D3.1	Tests campaign and tool validation report	6 months	T0 + 24 Months

**6. Topic value (€)**

The **maximum value** for this topic is

**300, 000 €.**

**[Three hundred thousand Euro]**

*Please note any proposal above this value will be NOT be eligible.*



## Topic description

CfP Nbr	Title	End date	T0 + 24 Months
JTI-CS-2013-2-SGO-02-081	Implementation carbon fibers for rotor of high speed rotating electric machine	<b>Start date</b>	T0 : Q4 2013

### 1. Background / topic description

As starting point, future Aircraft needs more electrical power on board, so the associated electrical rotating machine weight increase can be a drawback for MEA architectures. Consequently the rotating electrical machine manufacturers are looking for solutions to reduce the mass of these machines. One of them is to increase the speed rotation of these machines.

In this aim, innovative fixation solutions for rotating parts must be developed to withstand these new mechanical stresses at these high speeds. Indeed the usual metallic rotor sleeve solution (e.g inconel) need to be replaced and carbon fibers or similar technologies are good candidates for this application.

This higher speed rotation combines highly variable environmental constraints, such as high surface temperature and also high mechanical strains. The rotating parts of electrical machine are subjected to high surface temperature between -50°C to 250°C, and to high mechanical constraints because of the operating speed increase over 50 000 rpm, today with existing metallic fixation the rotation speed is limited to 30 000 rpm. Detailed requirements, design of the rotor parts, environmental conditions, will be given to the applicant at the beginning of the project. Dimensions of the rotor are around 300mm long and 200mm diameter.

The goal of this topic is to find partner(s) able to develop a rotor fixation solution with composite technologies and able to propose a manufacturing process. It would be advantageous for the partner to consider how the system could be designed, manufactured and tested.

TRL5 is expected at the end of the project.

### 2. Scope of work

The following tasks shall be performed by the applicant:

**Task 1 : State of the art : carbon fiber, composite technologies and manufacturing process**

Applicant is requested to investigate general state of the art of composite fixation and manufacturing process for rotating parts and to present a large range of available and/or future technologies for this application as well as patents related to these technologies and these manufacturing processes.

**Task 2 : Analyze the topic manager requirements**

Applicant is requested to analyze the requirements, current designs and environmental constraints. Proposal of a manufacturing process (winding, composite process, process control,...) with a pre-assessment of recurrent and non-recurrent costs.

Applicant is requested to define a list of criteria to characterize performance and robustness, and the associated means of compliance. This work will lead to a test matrix proposal.

Criteria will have to be identified in the analysis:

- Performance criteria: quality of manufacturing process (mechanical stresses on the fiber, reproducibility,...).
- Robustness criteria: life time, integration facilities, potential defects, endurance,...

**Task 3 : Modeling and evaluation constraints**

Applicant is requested to modelize mechanical constraints on the rotor parts. ANSYS software is recommended.

Applicant is requested to evaluate stresses through temperature and rotation speed spectrum seen by the rotating parts during operation.

**Task 4 : To manufacture rotor mock-up, and manufacturing process**

Applicant is requested to produce the composite fixation on rotor and define the manufacturing process parameters.

## Clean Sky Joint Undertaking SP1-JTI-CS-2013-02-SGO-02-081

The topic manager will deliver rotor mock-up (quantity: 5 units for two runs (3 units for the first run and two units for the second run to optimize the process)).

**Remarks to take account:** Applicant shall show its capability:

- to guarantee a process monitoring with real-time control of parameters (before curing and post curing the control of the moisture and limit of oxidation degradation and measure the resultant force on the mechanical parts of the rotor),
- to ensure reproducibility of the process,
- to ensure its transfer to an industrial scale.

### **Task 5: To evaluate the mock-ups**

Applicant is requested to prepare (instrumentation, data acquisition to measure mechanical and fatigue capabilities on the rotor during the process), to realize and to analyze tests (performance, robustness and endurance tests).

Applicant is requested to measure geometrical parts during all the process manufacturing to validate the calculation results, and to evaluate the failure mechanisms of selected technologies with identification of ageing laws.

Tests activities will have to be approved by the customer.

### **Task 6: Optimization (Run 2 to optimize the process)**

Applicant is requested to prepare a second run of tests to complete the analysis or to confirm the manufacturing process with a second rotor type (similar rotor delivered by topic manager),

Applicant is requested to optimize the mechanical constraint model,

Applicant is requested to deliver reports on performances with results tests, on robustness and on process manufacturing and to deliver the mechanical model.

Applicant is requested to propose a maturation test plan to mature the selected technology up to TRL5.

## **3. Type of work**

Phase 1 (T0+3M): state of art and analyse topic manager requirements, (realization tasks 1 and 2)

Phase 2 (T0+11M): definition of the model and the process manufacturing with realization of mock-ups (RUN1), (realization tasks 3 and 4)

Phase 3 (T0+17M): evaluation of the mock-up and process manufacturing according to matrix test proposal with mechanical and robustness performance tests, (realization task 5)

Phase 4 (T0+24M): model and process manufacturing optimizations with the RUN2 mock-up tests. (Realization task 6)

## **4. Special skills, certification or equipment expected from the applicant**

The applicant should have the following knowledge & equipment:

- Strong knowledge of carbon fibres and composite technologies,
- Strong knowledge and extensive experience on composite calculation & process simulation,
- design and product method for composite application on rotating parts,
- Strong knowledge, extensive experience and capabilities to characterize composite (resins) properties (Tg, DSC, DMA, viscosity, mechanical testing ...),
- conduct fatigue and combined robustness tests,
- Facilities for implementing the process in an industrial scale.

The applicant should have the following experience in management project:

The activity will be managed with a Phase & Gate approach and management plan has to be provided. The Topic Manager will approve gates and authorise progress to subsequent phases.

Technical and programme documentations, including planning, drawings, manufacturing and inspection reports, must be made available to the Topic Manager.

Experiences in R&T and R&D programs. Experience of aerospace related research programs would be an advantage. In-house testing capability will have to be emphasized in order to propose an integrated design, manufacturing and testing approach.

Availability of test benches to support test campaigns is mandatory.

**Clean Sky Joint Undertaking**  
**SP1-JTI-CS-2013-02-SGO-02-081**

English language in mandatory.  
Activities shall be conducted using ISO standards.

**5. Major deliverables and schedule**

<b>Deliverable</b>	<b>Title</b>	<b>Description (if applicable)</b>	<b>Due date</b>
D1	Report of state of the art : composite technologies and the manufacturing process according to requirements and constraints, with test matrix proposal	Report of tasks1 and 2	T0 + 3 Month
D2	Modeling and evaluation constraints	Model (task 3)	T0 + 5 Months
D3	Delivery of rotor mock-ups (RUN1)	Mock-up (task 4)	T0 + 11 Months
D3	Run 1 tests report with model	Task 5	T0 + 17 Months
D4	Run 2 tests report and optimization model	Task 6	T0 + 24 Months

**6. Topic value (€)**

The **maximum value** for this topic is:

**500, 000 €.**

**[Five hundred thousand Euro]**

Please note any proposal above this value will NOT be eligible.

## Topic description

CfP Nbr	Title	End date	TO + 20 Months
JTI-CS-2013-2-SGO-02-082	Lithium-ion energy storage module for Integrated 28Vdc Modular Power system	<b>Start date</b>	TO : Q1 2014

### 1. Background

#### Battery vision:

Main purpose for this call for proposal 15 is not to study an improvement of electronic part (Battery Management System (BMS) or battery charger (battery charger function will be done in the call 14 (SGO-02-072)) for existent monolithic lithium-ion batteries but to develop and to extend the modular concept to this storage energy system. This innovative concept will allow managing the onboard energy and the power dedicated for more electrical aircraft.

Existent functions in BMS of standard monolithic batteries are limited to check and to monitor thresholds of cells voltage and temperature; and to alarm the system in case of failure. The drawback of this monolithic battery is to lose this key equipment in case of detection of any failure mode (battery is declared failed and cannot be used)

In case of modular concept, this BMS will be designed with more relevant functions in order to allow fault tolerance to avoid any battery loss when failure event occurs. The applicant will have to be a source of proposal to establish the new functions, as self-diagnostic and mechanism to configure the battery panel with the need (scalability and optimization of weight, volume ...).

#### Aircraft architecture vision:

Current generation of unregulated 28vdc power system impacts significantly the design of the aircraft wiring and avionics loads due to its relatively poor network power quality. The use passive power converter technology coupled with NiCad battery penalizes significantly the overall weight. Moreover in many cases a dedicated power converter is used to charge the battery and manage its operation. With the electrification of primary and secondary flight control system, new electrically actuated loads need to be powered from aircraft 28Vdc system and associated battery.

The development of a new generation of integrated 28Vdc modular power conversion / energy storage system with features such as 28Vdc sources hybridization, full DC regulation, controlled and coordinated battery charge /discharge management and non-interruptible capabilities is crucial to further optimize aircraft wiring, avionics load design, battery sizing and provide power to new flight control load during emergency condition.

With the emergence of high power density lithium-ion battery technology and the recent power electronics advancement, the new generation of 28Vdc system regroups and integrates lithium energy storage modules and active power conversion modules together to create an integrated scalable 28Vdc modular hybrid power conversion / energy storage system.

The Hybrid modular / fault tolerant power converter / energy storage system optimizes system availability, dispatch reliability, DOC/DMC as well as overall weight requirement. Those new integrated hybrid technology system leverages progress in active power conversion, multifunction power core and modular lithium energy storage system to provide optimal performances to the aircraft. Integrated Power Conversion / Energy Storage system solutions provide a unified HW platform for PCS / Energy Storage aircraft applications with a modular rackable Plug and Play Smart PCS / Energy Storage System. The system is capable to evolve and meet customer requirement by scalability and use modular chassis with integrated Energy storage / Conversion / Distribution rackable LRM Boards.

The expected benefit with modular battery concept at aircraft system level will be a better management of onboard power and energy. Naturally, during this CFP, the selection of raw materials to build li-ion module will be one of key criteria regarding safety and reliability aspects, For this application, the applicant shall propose a good compromise between energy and power capacity battery technologies.

### 2. Scope of work

The objective is to develop a lithium-ion energy storage module and its associated BMS capable to interface with an advanced active modular power conversion 28Vdc system. Lithium energy storage module design and architecture is the key element of those new hybrid 28Vdc modular system and

## Clean Sky Joint Undertaking SP1-JTI-CS-2013-02-SGO-02-082

need to be carefully developed with product breakdown structure and adequate functional partitioning. The lithium energy storage module architecture need to be develop including criteria such as

1. Scalability and openness of solutions
2. Weight / volume module optimizations at foreseen application
3. Optimization of RC, DOC and DMC
4. Function partitioning between lithium-ion energy storage module and power converter
5. lithium-ion energy storage module connection for no break
6. Lithium-ion module safety architecture and electrochemistry needs.
7. Modular / Rackable Plug and play system
8. Integration of modular battery pack with power converter and distribution boards (activity to be share with the applicant and the company of topic manager).

This study shall include the following technical parts and activities:

- a) Updated State of the art & trade study of existing and advanced lithium-ion module and BMS architecture.
- b) Selection and study of limited advanced lithium-ion module architecture
- c) Description of final advanced lithium-ion module hardware design solution
- d) Validation tests of advanced lithium-ion module demonstrators
- e) Manufacturing and delivery of hardware samples for internal verification and validation at aircraft levels.

Progress reports will be requested every month.

### 3. Type of work

The activities of this work shall be limited to 18 months' time period. A kick-off meeting, a progress meeting and final meeting will be scheduled with topic manager. This project is split into following tasks proposed for the applicant activities:

- Task 1 (T0+2M): definition of lithium module architecture and associated BMS architecture,
- Task 2 (T0+6M): definition of the lithium module and associated BMS detailed architecture and product breakdown structure and function partitioning
- Task 3 (T0+12M): lithium module and associated BMS mock-up prototype
- Task 4 (T0+20M): Evaluate electric performance according to evaluation procedures specification jointly by the applicant and topic manager.

### 4. Special skills, certification or equipment expected from the applicant

The partner shall have strong knowledge and experience of Aerospace Li-ion battery system including safety design and electro-chemistry performances optimizations. The partner shall have test, integration and simulation means for the development and the integration of the overall system.

For this study, the applicant shall satisfy following minimum criteria:

- Expert in Aerospace Li-Ion battery system with flight tests experiences of Li-Ion battery module,
- Experiences in power density and isolated tension constraints,
- Insurance shall be provided to manage this work in time without delay for study and development phases,
- Adequate equipment with tools, for thermal, electrical and mechanical simulations, manufacturing process and test benches to develop and test requested demonstrators in respect with milestone of delivery,
- Available resources to execute the respective tasks should be stated in the proposal.

### 5. Major deliverables and schedule

Deliverable	Title	Description (if applicable)	Due date
D1	Report battery module architecture		T0 + 1 Month
D2	Delivery of prototypes		T0 + 12 Months
D3	Report on performances		T0 + 15 Months
D4	Report on integration tests		T0 + 20 Months

**Clean Sky Joint Undertaking**  
**SP1-JTI-CS-2013-02-SGO-02-082**

**6. Topic value (€)**

The maximum value for this topic is:

**600, 000 €.**

**[Six hundred thousand Euro]**

Please note any proposal above this value will NOT be eligible.

## Topic description

CfP Nbr	Title	Start date	TO: Q1 2014
<i>JTI-CS-2013-2-SGO-03-024</i>	On-Board Information Correlation for a pilot's complete situational awareness in optimum trajectory decisional process.	<b>End date</b>	<i>TO + 18 Months</i>

### 1. Background

The Clean Sky Systems for Green Operations ITD, and in particular the Management of Trajectory and Mission (MTM) work package, aim to demonstrate that a significant reduction in environmental pollution can be achieved by means of more precise, reliable and predictable Green Trajectories, optimised for minimum noise and emissions in each flight phase, including agile trajectory management in response to unattended events, (e.g. the insurgence of unforecast weather phenomena). In the selection of the new optimized trajectory, the pilot is compelled to face with a set of different and often uncorrelated weather and traffic data collected at different times and having different reliability and accuracies, while he should need a restricted number of parameters to input to the on-board trajectory optimization Decision Support System for a ready decision.

### 2. Scope of work

New future ATM concepts undevelopment in different programs will leave to pilots greater freedom of choice in the trajectory selection also in modifying the Reference Business Trajectory in facing unforeseen situations.

In addition System Wide Information Management (SWIM) and future Airspace ConOps make available to the pilot a huge amount of direct information coming from very different sources (satellites, other aircraft, ADS-B, ATC, etc.), while other sources of indirect data could be devised using already available on-board instruments.

All this information sources, while contributing to the need of increasing the pilot's awareness about the situation the aircraft is going to meet, also increase the pilot's burden with the need to evaluate the real importance and correctness of data and/or to analyze the threat posed by the new event by correlating data coming from different sources derived at different times and having different reliability and accuracy.

In particular, when, as usual, the new event is a changing weather situation, the decision on trajectory diversion is often difficult due to the need of integrating and correlating information coming from:

- On-board sensors, mainly the airborne weather radar which in a near future will implement new functions able to provide the pilot with enhanced information compared to the present operating systems; but also the lightning detector, WINS, and the ADS-B.
- Periodically updated weather forecast (METAR, TAF, PIREP, etc.)
- NOTAMs coming from the communications system.
- Information coming from other users and/or sources according to SWIM concepts: GPS, satellite receivers, etc...(in this case suggestions proposed by the applicant about the use and integration of such sources into the usual data management will be greatly appreciated especially if concerning the way of using already available instrumentation for increasing information reliability).

All this information delivered in different times must be collected, integrated filtered, correlated, made coherent and the output of this analysis provided in a suitable format (e.g.:GRIB files) to be used as input of a trajectory optimization system. This process would allow to provide the pilot with a more concise and meaningful unbiased evaluation of the threat - also taking into account the aircraft performances and surviving capabilities – able to be used also as main parameter(s) in the optimization of trajectories based on environmental considerations.

The subject of the call shall therefore be the study of the different weather and airtraffic data sources, the simulation of the data stream, the data analysis and fusion, the provision of a GRIB file containing all the useful information with a suitable accuracy.

The main output will be the development of a SW system implementing algorithms oriented to the

## Clean Sky Joint Undertaking SP1-JTI-CS-2013-02-SGO-03-024

fusion of data directly coming from the present and future expected sources above listed and indirectly from other sources, with different reliability, accuracy and timeliness aimed to provide in output an objective measurement of the hazard faced by the aircraft in the new situation to be input to the trajectory optimization algorithms in development in the SGO-MTM WP.

The work can be divided into the following steps to be furtherly detailed under Topic Manager specifications:

1. Study of information sources on unforecasted events (weather changes, traffic congestion, runway unavailabilities, etc...) and their characteristics in present and future ATM environment: quality, consistency, latency, accuracy, timeliness, reliability evaluation, etc...
2. Proposal about the use of new direct and/or undirect information sources by using future or already available on-board instrumentation
3. Definition of data transformation algorithms for decoding, extraction, evaluation, integration, correlation and data fusion of the information coming from the above assessed different sources aimed to get the maximum situational awareness about new unforecast events.
4. Provision of the output of the processed data in GRIB file format
5. Definition of unbiased threat/importance factor(s) extracted from the above correlated information to be deployed to the pilot in the most suitable way as a valid help in his decision making process and to be used as weight parameter(s) by the Q-AI trajectory and mission optimization algorithms.
6. Development of a SW based simulation environment (running on a standard machine) to simulate the information delivery from the different sources according to the selected unexpected scenarios described at point 1.
7. Development of a SW package implementing the correlation and raw data fusion algorithms to provide the useful enhanced information to pilot and to the trajectory optimization algorithms.
8. Workshop and dissemination to provide tool information to all the partners

**Documentation:** The following type of documentation (detailed in section 5) shall be issued during the programme development:

- a) Periodic Progress Reports
- b) Technical Reports
- c) User Manuals: User manuals will be issued for facilitating the user to operate with both the sources simulator and the data fusion SW package. In particular, details concerned the interface to the pilot and to trajectory optimization algorithms must be provided too.
- d) Commented source codes
- e) Software Description including flow charts and I/O data formats of the routines.

### 3. Type of work

Preliminary studies about information sources in present and future ATM environment.

Proposal about the use of innovative information sources.

Development of software packages implementing both the simulator of different information sources and the correlation and data fusion of information to get unbiased threat evaluation parameter(s).

Provision of the data processing and fusion output in a standard format (GRIB file)

Provision of significant simulated scenarios.

### 4. Special skills, certification or equipment expected from the applicant

The applicant shall demonstrate the capability to satisfy all the above listed requirements and, in particular, the capability of addressing and analysing the data extraction and correlation problems from different avionics sources (in particular weather radar, ADS-B, WINS, lightning detector) according to the present and future ATM concepts .

The applicant shall demonstrate aptitude for innovation in deriving and analysing possible use of the data coming from both direct and indirect sources not used up to now to increase the quality of available information.

A system expertise in simulation environments and techniques and data fusion SW development, especially



## Clean Sky Joint Undertaking SP1-JTI-CS-2013-02-SGO-03-024

related to information processing, is required for the definition of the different operative scenarios and for the implementation of information correlation functions.

A research team with deep skills in all mentioned scientific fields is required to cover every aspect of the project (in particular meteorology, avionics and civil aircraft rules

### 5. Major deliverables and schedule

Deliverable	Title	Description (if applicable)	Due date
D1.n	Periodic Progress Reports	Reports on the work in progress will be issued at regular time intervals (every three-months), describing the activities performed and the results obtained in the period, as well as the progress on next deliverables and review milestones.	T <sub>0</sub> + 3 x n months
D2	Statement of Work	Description of the different activities in which the overall programme must be divided (WBS) and for each WP the allocated resources and costs, the time schedule and the relationship with other activities. Such document must confirm the WBS presented in the proposal (see section 7) and must be agreed with SelexGalileo.	T <sub>0</sub> + 0.5 month
D3	Study on on-board information sources according to SESAR ConOps.	An overview of the different presently (JAA, FAA) and foreseen (SESAR) available sources of information (weather radar, NOTAMs, weather forecast, etc...) shall be issued with evaluation of their quality in terms of reliability, timeliness, accuracy, consistency, etc... Proposal for getting useful data from other sources not considered up to now to increase on-board information shall be included in this document.	T <sub>0</sub> + 4 months
D4	On-board Data stream Simulation	SW of on-board data stream in HLA, CIGI and DDS format should be provided.	T <sub>0</sub> + 5 months
D5	Scenarios Analysis Document	Document describing several different scenarios where the need for changes in the aircraft trajectory/mission can arise and the pilot's needs (in form of requirements) in the described situations.	T <sub>0</sub> + 6 months
D6	Data Fusion SW Architecture Design	Technical report describing the overall architecture of the Data Fusion SW to correlate the raw data coming from different sources to generate a concise information to be presented to the pilot and to be used by the Q-AI.	T <sub>0</sub> +6 months
D7	Test Plan	Technical document describing the simulation environment (SW data sources simulator) and the tests to be performed on the defined scenarios to demonstrate the achievement of the requirements	T <sub>0</sub> +12 months
D8	Software Description Document	Describing the Software and the implemented functions w.r.t. to the requirements for both the simulation environment and the data fusion package.	T <sub>0</sub> +12 months
D9	User Manual	User Manual describing how to use the implemented SW, for both the simulator of data sources and data fusion package.	T <sub>0</sub> +15 months
D10	Test Report	Technical report on the results of performed tests in accordance with the Test Plan.	T <sub>0</sub> +17 months
D11	Tested SW code	Final software release, source code	T <sub>0</sub> +17 months
D12	Workshop and Software tool demonstration	Workshop and SW tool demonstrations to let all SGO partners to evaluate the outputs	T <sub>0</sub> +18 months

## Clean Sky Joint Undertaking SP1-JTI-CS-2013-02-SGO-03-024

### 6. Topic value (€)

The **maximum value** for this topic is:

**650, 000 €**

**[Six hundred fifty thousand Euro]**

Please note any proposal above this value will NOT be eligible.

### 7. Remarks

*Management policy:*

- *In proposal the applicant must provide a Gantt diagram of the work, dividing the required activities in clearly defined work packages and indicating for every WP time schedule, required input and delivered output, in accordance with the scheduled deliverables listed at the previous section 5.*
- *Management & progress meetings shall be periodically planned during the entire project to evaluate activities progress, agree on requirements and results assessments, prepare milestones and reviews, and deal with project management issues.*
- *Further technical meetings shall take place on SGO Topic's manager request, in order to discuss in details specific technical points.*

# Clean Sky Joint Undertaking

## SP1-JTI-CS-2013-02-SGO-03-025

### Topic description

CfP Nbr	Title	End date	TO + 12 Months
JTI-CS-2013-2-SGO-03-025	Automatic flight plan management tool for integration in bench for avionics equipment validation		
		Start date	TO: Q1 2014

### 1. Background

The SGO part of Clean Sky aims at developing systems which enable environmentally sustainable flight operations. FMS functions have been developed, covering the departure, cruise and approach phases. For TRL5 and 6 review it is necessary to confirm results obtained, at TRL3 and 4 of green FMS functions, in term of robustness by validation scenarii that cover a wide range of conditions (A/C parameters, flight plans, meteo conditions, etc).

The present call aims at providing a tool able to manage a large number of flight plans, from actual flights, and to be integrated to an FMS test bench.

### 2. Scope of work

Description of work – Summary

Airlines public flights consultation and use in test bench is required to perform new Cleansky functions evaluation according to operational flights.

The objective of the CFP will be :

- to provide airlines public flight plans database, with associated consultation means,
- to provide FMS bench compatible mean to inject flight plans from this database in FMS equipment under test

#### Expected work

##### **Database scope**

- Create a flight plan database containing all public information for each published flight (date/time, airline, aircraft type, flight plan, altitudes, etc...). The database sources could be for example from IFPS, OACI and other similar formats.
- Define and implement a durable airlines public flight plans gathering process to fill the flight plan database with significant start dataset, and regular data update with new flights

##### **Database consultation scope**

- Provide database consultation means, in two ways :
  - Interactive visualization tool
  - Batch query mode over network

#### **Overview**

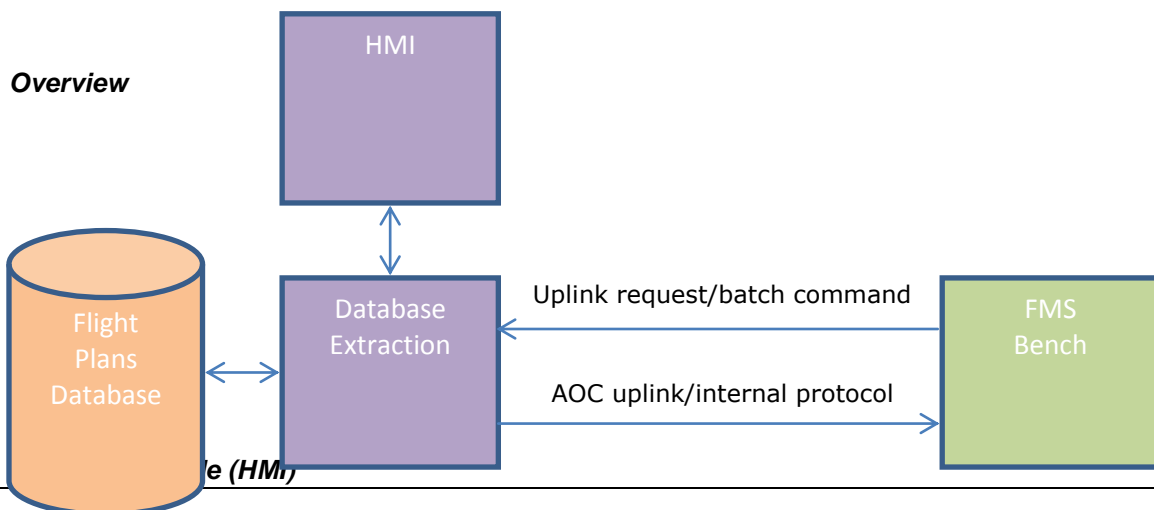

## Clean Sky Joint Undertaking SP1-JTI-CS-2013-02-SGO-03-025

- Display flight plans on world map
- Display synthetic flight plan form
- Provide research tools for database exploration (search criterias to be defined)
- Provide capability to create or modify flight plans

### ***Batch query mode***

- provide application able to inject selected flight plan into FMS under test on bench:
  - using AOC standard protocol (coded and transmitted over network)
  - using industrial protocol (to be defined)
- provide flight plan injection from bench remote command or HMI selected element
- provide remote bench control to restart/request fpln/interrogation query from test automaton.

### **Major technical requirements**

Database and associated tools are expected to be delivered as a software package running on one Microsoft Windows XP & Seven Operating Systems. Both shall run on current PC generation and share processing resources with others applications.

AOC response time from flight plan transmission ordered by remote/interactive command, to effective AOC emission to FMS shall not exceed few seconds.

AOC emission shall be delivered as network communication, determined by external textual configuration (for example: udp/tcp ip port).

### **3. Type of work**

Software development: Flight Plan Data gathering process implementation, database and associated tools provision.

### **4. Special skills, certification or equipment expected from the applicant**

Skills in Software development, Graphical User Interface implementation

The tool developed will be provided for use in Clean Sky and further R&D project to SGO/WP3.6 participants.

### **5. Major deliverables and schedule**

Deliverable	Title	Description (if applicable)	Due date
D1	Development plan		T0 + 1 Month
D2	Database description (data, fields, ...) and update process	Includes database filling process description (first step and updates)	T0 + 2 Months
D3	Tool Specification	Consultation HMI description, including search capabilities (GUI functional specification) Batch mode description (queries, protocols, ...) – Interface control document	T0 + 4 Months
D4	Database and tools Validation plan		T0 + 5 Months
D5	Database and tools design documentation & design justification		T0 + 8 Months
D6	First database and tools delivery	Includes initial version of User Guide	T0 + 10 Months
D7	Final database and tools release		T0 + 12 Months

## Clean Sky Joint Undertaking SP1-JTI-CS-2013-02-SGO-03-025

Deliverable	Title	Description (if applicable)	Due date
D8	Database and tools user guide		T0 + 12 Months

### 6. Topic value

The **maximum value** for this topic is:

**500, 000 €.**

**[Five hundred thousand Euro]**

Please note any proposal above this value will NOT be eligible.

### 7. Remarks

#### **Reporting**

Progress reports (monthly) will include the following elements:

Description of activities performed

Status of all deliverables and review milestones

#### **Meeting and review policy**

Management & progress meetings shall be planned at the issue of each Progress Report to evaluate activities progress, agree on requirements and results assessments, prepare milestones and reviews, deal with project management issues and discuss in details specific technical points. Each deliverable shall be submitted to the Topic Manager and issued after his approval.

## Topic description

CfPNbr	Title	Start date	T0: Q1 2014
JTI-CS-2013-2-SGO-03-026	Antenna system design and testing for an avionic weather polarimetric X-band radar	End date	T0 + 18 Months

### 1. Background

The Clean Sky Systems for Green Operations ITD, and in particular the Management of Trajectory and Mission (MTM) work package, aim at demonstrating that the achievement of pollution reduction can be supported by more precise, reliable and predictable Green Trajectories, optimised for minimum noise and emissions in each flight phase, including agile trajectory management in response to unpredicted events, (e.g. the insurgence of unforeseen weather phenomena). The use of polarimetric radar has been proposed as the enabling technology for higher performances in classifying weather phenomena and therefore for optimizing the avoidance trajectory from the Clean Sky point of view. The capability of polarimetry in providing better description of weather phenomena has been already demonstrated by developing new radar signal processing and post-processing techniques useful for providing information to an Artificial Intelligence-based trajectory optimizer confirming the avionic polarimetric radar as one of the most promising technological solutions to be implemented and installed in the new civilian aircrafts. Nevertheless, polarimetric radars have an architecture much more complex than a classical single polarization radar presenting critical items the performances of which must be demonstrated. One of these critical items is the antenna where several constrains like weight, size, cooling, cross-pol and co-pol couplings and cost make its design and realization a challenging task. In the open market several polarimetric antennas have been realized for aircraft platform but mainly referred to side-looking or squint looking SAR, where the antenna is typically mounted on pods under the airplane wings or under the fuselage, with no so strict room constraints. Conversely, for avionic radars, the antenna must be mounted on the aircraft nose, where room, shape, electrical and mechanical interfaces and interaction with other on board devices represent strong constraints in its design.

In this context, the selection of the most suitable technology, the design and the testing of a breadboard/prototype avionic polarimetric radar antenna (for performance evaluation without final form factor) is mandatory before assessing the design of a complete polarimetric radar in order to better understand the feasibility of such a critical subsystem as well as technological gaps (if any) and critical aspects to be filled.

### 2. Scope of work

The scope of the call is the design of a polarimetric avionic radar antenna operating at X-band for weather characterization and classification. The validation of the antenna design is required using two different approaches: 1) simulation, where the overall antenna performances are analysed and demonstrated; 2) realization of an antenna breadboard/prototype and testing of its performances through suitable measurements to demonstrate the validity of the design methodology.

The work should be divided into the following steps to be further detailed under Topic Manager's specifications:

9. Antenna system requirements definition
10. Survey and critical analysis of the available polarimetric X-band radar antenna technologies and selection of the most suitable architecture for airborne weather radar applications
11. Array antenna modelling and design
12. Performance analysis via numerical simulation
13. Implementation of a breadboard/prototype antenna with no final form, but suitable to infer final performances (e.g.: a sub-array of a greater complete array antenna).
14. Breadboard/prototype measurements
15. Validation of the antenna design methodology through measurement data analysis
16. Technological roadmap for full device implementation

## Clean Sky Joint Undertaking SP1-JTI-CS-2013-02-SGO-03-026

**Documentation:** The following type of documentation (detailed in section 5) shall be issued during the programme development:

- f) Periodic Progress Reports
- g) Technical Reports
- h) Measurement data archives

### 3. Type of work

Preliminary analysis of the polarimetric X-band radar antennas  
 Selection of the most suitable technology for civil airborne applications  
 Antenna design methodology definition  
 Antenna modelling and simulation  
 Breadboard/prototype antenna realization  
 SW tools for design methodology validation  
 Measurements for performance analysis

### 4. Special skills, certification or equipment expected from the applicant

A research team with deep skills in all mentioned scientific fields is required to cover each aspect of the project. In addition the applicant must prove their expertise describing previous experiences in such fields

In particular the applicant shall demonstrate to have the below listed skills and equipment:

- 1) Familiarity with avionic X-band radar demonstrating the capability for critical analysis of the antenna characteristics
- 2) Expertize in weather radar system design and analysis
- 3) Expertize in antenna design and modelling
- 4) Capability of antenna technological demonstrator realization
- 5) Experience in laboratory and anechoic chamber measurements

### 5. Major deliverables and schedule

Deliverable	Title	Description (if applicable)	Due date
D1.n	Periodic Progress Reports	Reports on the work in progress shall be issued at regular time intervals (every three-months), describing the activities performed and the results obtained in the period, as well as the progress on next deliverables and review milestones.	$T_0 + 3 \times n$ months
D2	Statement of Work	Description of the different activities in which the overall programme must be divided (WBS) and for each WP the allocated resources and costs, the time schedule and the relationship with other activities. Such document must confirm the WBS presented in the proposal (see section 7) and must be agreed with Selex-ES	$T_0 + 1$ month
D3	Antenna system requirements	Document describing the antenna system requirements. These requirements must be defined in accordance with the application needs of the SGO-ITD-MTM	$T_0 + 2$ months
D4	Airborne antenna technology selection	This document reports the technological solutions adopted in existing X-band polarimetric radar in order to clearly understand the best technological choice. The approval of this document shall be a technical review milestone for the continuation of the program.	$T_0 + 4$ months
D5	Array antenna modelling and design	Technical report describing the antenna architecture and reporting the antenna design and modelling methodologies.	$T_0 + 10$ months
D6	Performance estimation through	The designed antenna will be validated through a numerical analysis. The report must include the numerical results and	$T_0 + 12$ months

## Clean Sky Joint Undertaking SP1-JTI-CS-2013-02-SGO-03-026

	numerical analysis	highlight possible critical aspects, risks and their mitigation. The reliability level of the results must also be quantified.	
D7	Breadboard/ prototype realization and measurements	This document shall contain the description of the realized breadboard/prototype antenna, the rationale used for its design and the measurements planned for the performance analysis	T <sub>0</sub> +18 months
D8	Validation of the antenna design through measurement data analysis	Measurement data analysis shall be reported in order to demonstrate that the proposed design approach is valid and applicable for the design and realization of the final X-band avionic radar antenna	T <sub>0</sub> +18 months
D9	Exploitation of results and technology roadmap	The report describes the technology roadmap necessary to exploit the results of the project in order to realize the final antenna and its commercialization.	T <sub>0</sub> +18 months

### 6. Topic value (€)

The **maximum value** for this topic is:

**630, 000 €**

**[Six hundred thirty thousand Euro]**

Please note any proposal above this value will NOT be eligible.

### 7. Remarks

*Management policy:*

- *In the proposal the applicant must provide a Gantt diagram of the work, dividing the required activities in clearly defined work packages and indicating for every WP time schedule, required input and delivered output, in accordance with the scheduled deliverables listed at the previous section 5.*
- *Management & progress meetings shall be periodically planned during the entire project to evaluate activities progress, agree on requirements and results assessments, prepare milestones and reviews, and deal with project management issues.*
- *Further technical meetings shall take place on SGO Topic's manager request, in order to discuss in details specific technical points.*
- *The applicant shall agree with Selex ES characteristics and performance derating of the breadboard/prototype antenna before its realization.*



## Topic description

CfP Nbr	Title	End date	T0 + 21 Months
JTI-CS-2013-2-SGO-04-009	Airline trials of green flight management functions	<b>Start date</b>	T0: Q1 2014

### 1. Background

The SGO part of Clean Sky aims at developing systems which enable environmentally sustainable flight operations. The MCDP (Multi Criteria Departure Procedure), ECO STEP and A-IGS (Adaptive Increased Glide Slope) concepts respectively focus on departure, cruise and final approach trajectory optimization.

The MCDP departure is a type of departure procedure whose objective is to master a compromise between fuel consumption and cumulated emitted noise on ground microphones located near an airport. It is a specific use of the ICAO defined NADP (Noise Abatement Departure Procedure) which is a standardized procedure characterized by 4 altitude and speed parameters (THR RED ALT, ACCEL ALT, PROCEDURE END ALT, SPEED) and an engine regime during early climb phase. Those five parameters are optimized by the new MCDP function.

The ECO STEP concept is an optimisation of the altitude changes for long-range cruise, using the on board knowledge of the wind forecast along the envisioned trajectory.

A-IGS consists in adapting the final glide path to the actual aircraft status and the environmental conditions, in such a way that the vertical speed at flare initiation is in an acceptable nominal range, previously fixed as an operational target. The increase of the height of the aircraft above the ground during the final approach phase together with reduction of the required thrust, are the main factors contributing to the reduction of ground noise under the flight path.

Laboratory studies on these concepts have shown potentially significant savings in terms of fuel consumption, CO<sub>2</sub>/NO<sub>x</sub> emissions and, specifically for departure phase, on ground perceived noise in airport vicinity. The goal of this Call for Proposal (CfP) is to determine whether these results are effective in daily operations context, which may imply random perturbation factors (such as ATM intervention, meteorological forecast error, dispersion on pilot actions), as well as real flight conditions (validation of modeling hypotheses). For this the involvement of an airline, and optionally of an airport operator is requested.

### 2. Scope of work

#### Description of work – Summary

Airline trials of FM functions :

The confirmation from end-user of their interest for innovative Flight Management (FM) functions is an important step in the higher maturity validation (TRL5 / 6). Therefore the objectives of this CfP are the following :

- to get airline analysis of the aforementioned FM functions and their compatibility with fleet and aircraft operations.
- to assess the environmental performance of a subset of the functions on a previously selected set of commercial flights. It is to be noted that the implementation of the function in the aircraft systems is not part of the CfP: scenarii will be implemented with support from tools developed and provided by SGO consortium, and the resulting parameters will be entered in the existing A/C systems by pilot manual actions, in order to emulate the effect of the future functions on the trajectory when relevant.

#### **Expected work :**

- analysis of the aforementioned FM functions and their compatibility with fleet and aircraft operations.
- Selection of the functions that can be emulated by pilot manual actions, with support from ground tools – in coordination with SGO consortium. Definition of the trial strategy.

## Clean Sky Joint Undertaking SP1-JTI-CS-2013-02-SGO-04-009

- Elaboration of a test plan including a selection of a sufficiently large set of representative commercial flights. Scenario definition items to be chosen are the following :routes, airports, meteo conditions, time of the day, traffic, etc.
- safety analysis of the experiment
- maturation of operational procedure on simulator and rehearsal with engineers and flight crews. (the new partner will provide the necessary simulators)
- definition with authorities of the experimentation regulation framework (if necessary).
- cooperative flight dynamics and emissions models calibration in order to transpose lab work oriented software to daily operation oriented software. This part shall include flight data recordings prior to the campaign itself, in order to characterise the performance of models (A/C performance model and noise and emission models)
- elaboration of the measurement plan for the campaign (liaison with airport authority for noise measurement when necessary).
- Organisation of Test Readiness Review before start of the flight campaign (expected around beginning 2015)
- cooperative work with an on-board engineer during selected flights, since the workload dedicated to experiment data providing and collecting may be significant.
- in flight data recording of selected flights, and noise measurement.
- provision of flight data to SGO for post treatment and analysis
- report on the tested scenarios.
- report on pollutants emissions: statistical comparative analysis (with significativity level) of CO2/NOx/Noise emissions and fuel consumption during experiments with emissions and consumption during nominal operations.
- acceptability analysis of proposed functions for airline stakeholders (flight crews, operation centre...)

### 3. Type of work

Cooperative work for evaluation of operational concepts and algorithm performance.

### 4. Special skills, certification or equipment expected from the applicant

Ability to operate **Airbus short and long range** aircrafts, ability to perform statistical studies and to collect aircraft data and noise recording.

An airline or a consortium including an airline and Airline Operation Centre service provider and airport operator is required.

### 5. Major deliverables and schedule

Deliverable	Title	Description (if applicable)	Due date
D1	Description of Workpackages		T0 + 2 Months
D2	Administrative framework	Operational approval...	T0 + 6 Months
D3	Selection of candidate flights		T0 + 7 Months
D4	Description of in flight procedure	Shall synthesize the choices justified by the rehearsal phase	T0 + 9 Months
D5	Description of data collection	Type and data and recording principle (on-board data and external data , e.g. weather, noise, etc)	T0 + 9 Months
D6	Calibration data	Flight data records useful for model transposition to daily operation context	T0 + 11 Months
D7	Description of statistical study to be performed	formulation of the analysis criteria for flight data results (filtering of abnormal cases, etc) for each kind of tested concept	T0 + 12 Months

## Clean Sky Joint Undertaking SP1-JTI-CS-2013-02-SGO-04-009

Deliverable	Title	Description (if applicable)	Due date
D8	Progress report of flights	Monthly update on progress	From T0 + 13 Months To T0 + 19 Months
D9	study report	It shall include, for each kind of tested concept <ul style="list-style-type: none"> <li>- recorded data</li> <li>- statistical study report</li> <li>- analysis of function acceptability</li> </ul>	T0 + 21 Months

### 6. Topic value

The maximum value for this topic is

**1, 800, 000 €.**

**[One million eight hundred thousand Euro]**

### 7. Remarks

#### **Reporting**

Progress reports (monthly) will include the following elements:

Description of activities performed

Status of all deliverables and review milestones

#### **Meeting and review policy**

Management & progress meetings shall be planned at the issue of each Progress Report to evaluate activities progress, agree on requirements and results assessments, prepare milestones and reviews, deal with project management issues and discuss in details specific technical points. Each deliverable shall be submitted to the Topic Manager and issued after his approval.

#### **Points of interest**

The result on perceived noise is an important issue for community surroundings airports and therefore specifically emphasized.

**Clean Sky Joint Undertaking**  
**Call SP1-JTI-CS-2013-02**  
**Technology Evaluator**

Clean Sky – Technology Evaluator

**No topics for Technology Evaluator**